









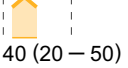
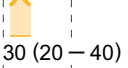

TECHNICAL DATA

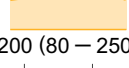
RECOMMENDED CUTTING CONDITIONS FOR TURNING.....	G002
RECOMMENDED CUTTING CONDITIONS FOR DIMPLE BARS.....	G004
RECOMMENDED CUTTING CONDITIONS FOR BORING BARS.....	G005
TROUBLE SHOOTING FOR TURNING.....	G006
REDUCING COSTS WITH CUTTING TOOLS FOR TURNING.....	G008
EFFECTS OF CUTTING CONDITIONS FOR TURNING.....	G009
FUNCTION OF TOOL FEATURES FOR TURNING.....	G011
FORMULAE FOR CUTTING POWER.....	G015
RECOMMENDED CUTTING CONDITIONS FOR FACE MILLING.....	G016
TROUBLE SHOOTING FOR MILLING.....	G017
FUNCTION OF TOOL FEATURES FOR FACE MILLING.....	G018
FORMULAE FOR MILLING.....	G020
TROUBLE SHOOTING FOR END MILLING.....	G022
PITCH SELECTION OF PICK FEED.....	G023
END MILL FEATURES AND SPECIFICATION.....	G024
TROUBLE SHOOTING FOR DRILLING.....	G026
FORMULAE FOR DRILLING.....	G027
DRILL FEATURES AND SPECIFICATION.....	G028
TOOL WEAR AND DAMAGE.....	G030
CUTTING TOOL MATERIALS.....	G031
GRADE CHAIN.....	G032
GRADES COMPARISON TABLE.....	G033
INSERT CHIP BREAKER COMPARISON TABLE.....	G038
MATERIAL CROSS REFERENCE LIST.....	G040
SURFACE ROUGHNESS.....	G044
HARDNESS COMPARISON TABLE.....	G045
FIT TOLERANCE TABLE (HOLE).....	G046
FIT TOLERANCE TABLE (SHAFT).....	G048
TAPER STANDARD.....	G050
DRILL DIAMETERS FOR TAPPING.....	G051
HEXAGON SOCKET HEAD BOLT HOLE SIZE / INTERNATIONAL SYSTEM OF UNITS.....	G052

RECOMMENDED CUTTING CONDITIONS FOR TURNING

RECOMMENDED CUTTING CONDITIONS FOR TURNING

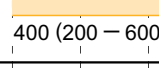
Work Material		Recommended Cutting Conditions and Grades				Breaker	When Recommended Conditions are Insufficient					
		Depth of Cut (mm)	Feed (mm/rev)	Coolant	Recommended Cutting Speed and Grades		Problem/Condition	Countermeasure				
					100	200	300	400				
Mild Steel Carbon Steel Alloy Steel	160 HB	Light Cutting	≤1.0	≤0.3	Dry	NX3035 290 (235 - 335)				SY	<ul style="list-style-type: none"> ● Long chips when finishing. ● Rapid wear occurrence in high speed cutting. ● Easy to fracture during interrupted cutting. ● Continuous cutting. 	FY Breaker UE6020 MS Breaker UE6020 Wet cutting is possible.
		Medium Cutting	1 - 6	0.4 (0.2 - 0.6)	Dry	UE6110 350 (260 - 440)				MS	<ul style="list-style-type: none"> ● Easy to fracture during interrupted cutting. ● Poor finished surface. ● Continuous cutting. 	UE6020 or MH or MA Breaker NX3035 Wet cutting is possible.
		Semi-Heavy Cutting	4 - 9	0.6 (0.5 - 0.8)	Dry	UE6110 350 (260 - 440)				MH	<ul style="list-style-type: none"> ● Easy to fracture. ● Continuous cutting. 	UE6020 or GH Breaker Wet cutting is possible.
	280 HB	Light Cutting	≤1.0	≤0.3	Dry	UE6110 280 (210 - 355)				SH	<ul style="list-style-type: none"> ● Long chips when finishing. ● Rapid wear occurrence when high speed cutting. ● Easy to fracture during interrupted cutting. ● Continuous cutting. ● High feed cutting (f ≥ 0.3) 	FH Breaker UE6005 UE6020 or MV Breaker Wet cutting is possible. SW Breaker
		Medium Cutting	1 - 6	0.4 (0.2 - 0.6)	Dry	UE6110 260 (190 - 325)				MV	<ul style="list-style-type: none"> ● Rapid wear occurrence when high speed cutting. ● Easy to fracture during interrupted cutting. ● Long chips. ● High feed cutting (f ≥ 0.4) ● Continuous cutting. 	UE6005 UE6020 or MH Breaker SH Breaker GH Breaker or MW Breaker Wet cutting is possible.
		Semi-Heavy Cutting	4 - 9	0.6 (0.5 - 0.8)	Dry	UE6110 250 (180 - 310)				GH	<ul style="list-style-type: none"> ● Rapid wear occurrence and short tool life. ● Easy to fracture. 	UE6005 UE6020
	350 HB	Light Cutting	≤1.0	≤0.3	Water Soluble Oil	UE6110 180 (120 - 230)				SH	<ul style="list-style-type: none"> ● Rapid wear occurrence when high speed cutting. ● Easy to fracture. ● Long chips. ● Interrupted cutting. 	UE6005 UE6020 FH Breaker Dry cutting
		Medium Cutting	1 - 4	0.3 (0.2 - 0.4)	Water Soluble Oil	UE6110 170 (120 - 210)				MH	<ul style="list-style-type: none"> ● Easy to fracture. ● Interrupted cutting. 	UE6020 or GH Breaker Dry cutting
	Austenitic Stainless Steel	≤200 HB	Light Cutting	1.0 ≤	0.2 ≤	Water Soluble Oil	U5735 140 (95 - 185)				SH	<ul style="list-style-type: none"> ● Long chips. ● Easy to fracture. ● Poor finished surface
Medium Cutting		1 - 4	0.3 (0.2 - 0.4)	Water Soluble Oil	U5735 120 (85 - 155)				MS	<ul style="list-style-type: none"> ● Rapid wear occurrence and short tool life. ● Easy to fracture. ● Long chips. 	US7020 or lower cutting speed. MA Breaker MA Breaker	
High Manganese Steel	≤200HB	1 - 4	0.2 (0.1 - 0.4)	Dry	UE6110 170 (120 - 210)				MS	<ul style="list-style-type: none"> ● Easy to fracture. ● Interrupted cutting. 	UE6020 UE6020	
Pure Titanium	≤200HB	0.5 - 1.5	0.15 (0.1 - 0.2)	Water Soluble Oil	RT9010 100 (80 - 120)				MJ	<ul style="list-style-type: none"> ● Rapid wear occurrence and short tool life. ● Easy to fracture. ● Interrupted cutting. 	RT9005 TF15 or GJ Breaker Use cutting oil.	
Titanium Alloy	≤350HB	0.5 - 1.5	0.15 (0.1 - 0.2)	Water Soluble Oil	RT9010 70 (40 - 90)				MJ	<ul style="list-style-type: none"> ● Rapid wear occurrence and short tool life. ● Easy to fracture. ● Interrupted cutting. 	RT9005 TF15 or GJ Breaker Use cutting oil.	

Work Material		Recommended Cutting Conditions and Grades				Breaker	When Recommended Conditions are Insufficient	
		Depth of Cut (mm)	Feed (mm/rev)	Coolant	Recommended Cutting Speed and Grades		Problem/Condition	Countermeasure
					100 200 300 400			
Nickel Base Alloy (Inconel, Waspalloy)		0.5 – 1.5	0.15 (0.1 – 0.2)	Water Soluble Oil	VP10RT  40 (20 – 50)	MJ	<ul style="list-style-type: none"> ● Rapid wear and short tool life. ● Lead angle ≤ 15° ● Interrupted cutting. 	MB730 (Cutting speed vc=100–250) VP05RT Increase lead angle to 30°–60°. Use cutting oil. VP15TF
Stellite (≤35HRC)		0.5 – 1.5	0.15 (0.1 – 0.2)	Dry	VP10RT  30 (20 – 40)	MJ	<ul style="list-style-type: none"> ● Rapid wear and short tool life. ● Hardness ≥ 35HRC. ● Lead angle ≤ 15° 	VP05RT VP05RT Increase lead angle to 30°–60°.
Die Steel High Speed Steel	200 – 280HB	1 – 4	0.3 (0.2 – 0.4)	Water Soluble Oil	UE6110  210 (150 – 260)	MH	<ul style="list-style-type: none"> ● Rapid wear and short tool life. ● Interrupted cutting. 	UE6005 UE6020, Dry cutting.
	50 – 60 HRC	-0.5	0.2 (0.1 – 0.3)	Water Soluble Oil	MBC020  200 (80 – 250)	Flat Top	<ul style="list-style-type: none"> ● Rapid wear and short tool life. ● Lead angle ≤ 15° 	MBC10 (Cutting speed vc=80–250) Increase lead angle to 30°–60°.
Gray Cast Iron	≤350 N/mm ²	1 – 6	0.4 (0.2 – 0.6)	Water Soluble Oil	UC5115  230 (160 – 295)	Standard	<ul style="list-style-type: none"> ● Rapid wear and short tool life. ● Easy to fracture. 	UC5105 UE6005 No breaker, chamfer honing, dry cutting.
Ductile Cast Iron	≤450 N/mm ²	1 – 6	0.4 (0.2 – 0.6)	Water Soluble Oil	UC5115  200 (160 – 295)	Standard	<ul style="list-style-type: none"> ● Rapid wear and short tool life. ● Easy to fracture. 	UC5105 UE6005 No breaker, chamfer honing, dry cutting.
	≤500 – 800 N/mm ²	1 – 6	0.4 (0.2 – 0.6)	Water Soluble Oil	UC5115  150 (100 – 200)	Standard	<ul style="list-style-type: none"> ● Rapid wear and short tool life. ● Easy to fracture. 	UC5105 UE6005 No breaker, chamfer honing, dry cutting.
Malleable Iron		1 – 6	0.4 (0.2 – 0.6)	Water Soluble Oil	UC5115  150 (100 – 200)	Standard	<ul style="list-style-type: none"> ● Rapid wear and short tool life. ● Easy to fracture. (interrupted cutting) 	UC5105 UE6005 No breaker, chamfer honing, dry cutting.
Chilled Cast Iron		1 – 6	0.4 (0.2 – 0.6)	Water Soluble Oil	UC5115  150 (100 – 200)	Standard	<ul style="list-style-type: none"> ● Rapid wear and short tool life. ● Easy to fracture. (interrupted cutting) 	UC5105 UE6110 No breaker, chamfer honing, dry cutting.
Aluminium Alloy		1 – 6	0.4 (0.2 – 0.6)	Water Soluble Oil	HT110  400 (200 – 600)	High Rake Breaker	<ul style="list-style-type: none"> ● High speed cutting. 	MD220 (Cutting speed vc=200–1500)
Copper Alloy		1 – 6	0.4 (0.2 – 0.6)	Water Soluble Oil	HT110  230 (150 – 300)	High Rake Breaker	<ul style="list-style-type: none"> ● High speed cutting. 	MD220 (Cutting speed vc=200–1200)
Sintered Alloy Steel		1 – 4	0.2 (0.1 – 0.3)	Dry	MB710  200 (150 – 250)	Flat Top	<ul style="list-style-type: none"> ● Low carbon steel. ● Medium carbon steel. ● High carbon steel. ● Thermal resistance. 	Cutting speed vc=200–250 Cutting speed vc=180–220 Cutting speed vc=150–180 Cutting speed vc=100–150

RECOMMENDED CUTTING CONDITIONS FOR DIMPLE BARS

RECOMMENDED CUTTING CONDITIONS FOR DIMPLE BARS

Work Material	Cutting Mode	Breaker	Recommendation	Grade	Cutting Speed (m/min)	l/d ≤ 3 (Steel shank) l/d ≤ 6 (Carbide shank)		l/d = 4-5 (Steel shank) l/d = 7-8 (Carbide shank)	
						Feed (mm/rev)	D.O.C. (mm)	Feed (mm/rev)	D.O.C. (mm)
P Mild Steel ≤ 180HB	Finish Cutting	F FS	①	NX2525	170 (120-220)	0.10 (0.05-0.15)	-0.5	0.10 (0.05-0.15)	-0.5
	Light Cutting	SV	①	NX3035	150 (110-190)	0.20 (0.10-0.25)	-1.0	0.15 (0.05-0.20)	-1.0
			②	VP15TF	180 (130-230)	0.20 (0.10-0.25)	-1.0	0.15 (0.05-0.20)	-1.0
	Medium Cutting	MV	①	NX3035	140 (100-180)	0.25 (0.15-0.35)	-2.0	0.20 (0.15-0.25)	-1.5
			②	VP15TF	160 (110-210)	0.25 (0.15-0.35)	-2.0	0.20 (0.15-0.25)	-1.5
	Carbon Steel Alloy Steel 180-280HB	Finish Cutting	F FS	①	VP15TF	140 (90-190)	0.10 (0.05-0.15)	-0.5	0.10 (0.05-0.15)
②				NX2525	130 (80-180)	0.10 (0.05-0.15)	-0.5	0.10 (0.05-0.15)	-0.5
Light Cutting		SV	①	VP15TF	130 (80-180)	0.20 (0.10-0.25)	-1.0	0.15 (0.05-0.20)	-1.0
			②	UE6020	140 (90-190)	0.20 (0.10-0.25)	-1.0	0.15 (0.05-0.20)	-1.0
Medium Cutting		MV	①	VP15TF	120 (70-170)	0.25 (0.15-0.35)	-2.0	0.20 (0.15-0.25)	-1.5
			②	UE6020	130 (80-180)	0.25 (0.15-0.35)	-2.0	0.20 (0.15-0.25)	-1.5
M Stainless Steel 180-280HB	Finish Cutting	F FS	①	VP15TF	150 (110-190)	0.10 (0.05-0.15)	-0.5	0.10 (0.05-0.15)	-0.5
	Light Cutting	SV	①	US7020	150 (110-190)	0.20 (0.10-0.25)	-1.0	0.15 (0.05-0.20)	-1.0
			②	VP15TF	130 (90-170)	0.20 (0.10-0.25)	-1.0	0.15 (0.05-0.20)	-1.0
	Medium Cutting	MV	①	US7020	140 (100-180)	0.20 (0.15-0.25)	-2.0	0.20 (0.15-0.25)	-1.0
			②	VP15TF	120 (80-160)	0.20 (0.15-0.25)	-2.0	0.20 (0.15-0.25)	-1.0
	K Cast Iron Tensile Strength ≤ 350N/mm ²	Finish Cutting	F FS	①	HTi10	130 (90-160)	0.15 (0.10-0.20)	-0.5	0.15 (0.10-0.20)
Medium Cutting		MV	①	US7020	90 (60-120)	0.20 (0.15-0.25)	-2.0	0.20 (0.15-0.25)	-1.5
H Heat Treated Steel 35-65HRC	Finish Cutting	Flat Top	①	MB825	100 (80-200)	0.10 (0.05-0.15)	-0.15	0.10 (0.05-0.15)	-0.1
N Aluminium Alloy	Finish Cutting	F FS	①	HTi10	300 (200-400)	0.10 (0.05-0.15)	-0.5	0.10 (0.05-0.15)	-0.5
		Flat Top	①	MD220	200 (150-250)	0.10 (0.05-0.15)	-2.0	0.10 (0.05-0.15)	-1.0

(Note 1) When vibrations occur, reduce cutting speed by 30%.

(Note 2) The depth of cut needs to be less than the nose diameter when using FSVJ type.



RECOMMENDED CUTTING CONDITIONS FOR BORING BARS

S TYPE, F TYPE BORING BAR

Work Material	Hardness	Cutting Mode	l / d ≤ 3			l / d = 3 - 4 (Shank Diameter ≥ φ25mm)		
			Cutting Speed (m/min)	Feed (mm/rev)	D.O.C. (mm)	Cutting Speed (m/min)	Feed (mm/rev)	D.O.C. (mm)
Carbon Steel Alloy Steel	180 - 220HB	Light Cutting	130 (90 - 160)	0.1 (0.05 - 0.15)	0.2	120 (80 - 150)	0.1 (0.05 - 0.15)	- 0.2
		Medium Cutting	90 (60 - 120)	0.25 (0.15 - 0.35)	- 3.0	80 (50 - 110)	0.15 (0.1 - 0.2)	- 1.5
Stainless Steel	≤ 200HB	Light Cutting	140 (100 - 180)	0.1 (0.05 - 0.15)	0.2	140 (100 - 180)	0.1 (0.05 - 0.15)	0.2
		Medium Cutting	70 (50 - 90)	0.2 (0.15 - 0.25)	- 2.0	60 (40 - 80)	0.15 (0.1 - 0.2)	- 1.0
Aluminium Alloy	-	Light Cutting	300 (200 - 400)	0.1 (0.05 - 0.15)	0.2	300 (200 - 400)	0.1 (0.05 - 0.15)	0.2
		Medium Cutting	200 (150 - 250)	0.1 (0.05 - 0.15)	- 2.0	200 (150 - 250)	0.1 (0.05 - 0.15)	- 1.5

P TYPE, M TYPE BORING BAR

Work Material	Hardness	Cutting Mode	l / d ≤ 3			l / d = 3 - 4		
			Cutting Speed (m/min)	Feed (mm/rev)	D.O.C. (mm)	Cutting Speed (m/min)	Feed (mm/rev)	D.O.C. (mm)
Carbon Steel Alloy Steel	180 - 280HB	Medium Cutting	110 (80 - 140)	0.25 (0.1 - 0.4)	- 5.0	110 (80 - 140)	0.2 (0.1 - 0.3)	- 4.0
Stainless Steel	≤ 200HB	Medium Cutting	80 (60 - 100)	0.2 (0.1 - 0.3)	- 4.0	70 (50 - 100)	0.15 (0.1 - 0.25)	- 3.0
Cast Iron	Tensile Strength ≤ 350N/mm ²	Medium Cutting	80 (60 - 100)	0.25 (0.1 - 0.4)	- 5.0	80 (60 - 100)	0.2 (0.1 - 0.3)	- 4.0

BORING BAR FOR ALUMINIUM

Work Material	Grade	Cutting Speed (m/min)	l / d = 3		l / d = 4		l / d = 5		l / d = 6	
			Feed (mm/rev)	D.O.C. (mm)	Feed (mm/rev)	D.O.C. (mm)	Feed (mm/rev)	D.O.C. (mm)	Feed (mm/rev)	D.O.C. (mm)
Aluminium Alloy	HTi10	400 (200 - 600)	0.15 (0.05 - 0.25)	- 3.0	0.15 (0.05 - 0.25)	- 3.0	0.1 (0.05 - 0.2)	- 2.5	0.1 (0.05 - 0.2)	- 1.0
	MD220	800 (200 - 1500)	0.15 (0.05 - 0.25)	- 3.0	0.15 (0.05 - 0.25)	- 3.0	0.1 (0.0 - 0.2)	- 2.5	0.1 (0.05 - 0.2)	- 1.0

TURNING (2)

Solution			Insert Grade Selection				Cutting Conditions				Style and Design of the Tool					Machine, Installation of Tool							
			Select a harder grade	Select a tougher grade	Select a grade with better thermal shock resistance	Select a grade with better adhesion resistance	Cutting Speed		Feed	Depth of Cut	Coolant		Select chip breaker	Rake	Corner Radius	Lead Angle	Honing strengthens the cutting edge	Class of Insert (Unground → Ground)	Improve tool holder rigidity	Installation of the Tool and Workpiece	Tool Holder Overhang	Machine with Inadequate Power and Rigidity	
Up ↗	Down ↘	Do not use water-soluble cutting fluid					Determine dry or wet cutting	Up ↗			Down ↘												
Trouble	Factors																						
			Damage at Cutting Edge	● Heavy Flank Wear and Crater Wear	Flank Wear	●				●				●	Wet	●	↗	↗	●				
Crater Wear	●						↘	↘	↘		●	Wet	●	↗		↗							
● Chipping	Shock and Vibration			●				↘	↘				●			↗	↗			●	●	●	
● Fracture	Improper grade selection and cutting conditions			●	●			↘	↘				●		↗	↗	↗			●	●	●	●
● Thermal Cracking	Improper grade selection, cutting conditions and material hardness				●		↘	↘	↘		●	Dry	●	↗			↘						
● Deformation of Nose Radius	Interrupted cutting, High feed rate	●					↘	↘	↘			●	Wet	●	↗	↗	↗						
Poor Chip Dispersal	● Long Swarf	Improper cutting conditions					↘	↗	↗		●												
		Improper shape of cutting edge or tool										●		↘	↘								
	● Scattering of Short Chip	Improper cutting conditions						↘	↘			●											
		Improper shape of cutting edge or tool										●		↗	↗								

REDUCING COSTS WITH CUTTING TOOLS FOR TURNING

MACHINING COST REDUCTION WITH CUTTING TOOLS

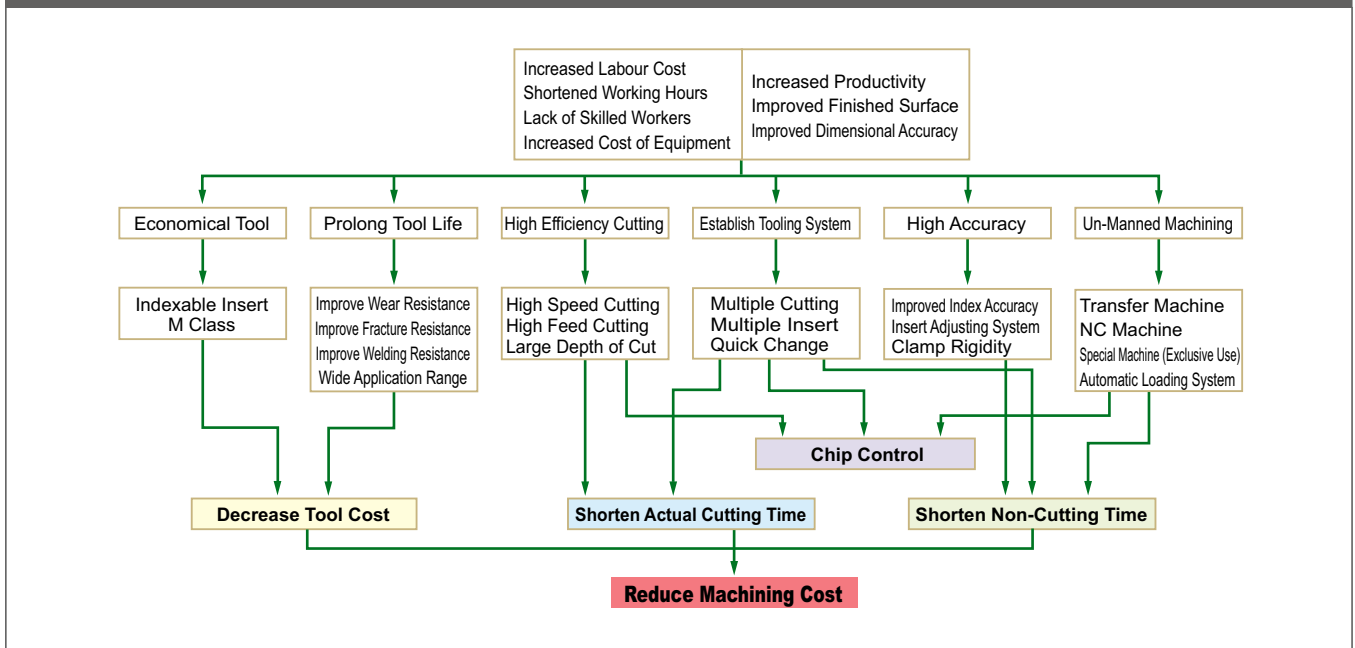

CHIP BREAKING CONDITIONS IN STEEL TURNING

		Type	A Type	B Type	C Type	D Type	E Type
Chip Breaking	Increase machinability of workpiece		Add machinable elements (Free Cutting Steel)	Heat treatment	Wet cutting		
	Increase chip thickness		Lower cutting speed	Increase feed rate	Decrease lead angle	Decrease rake angle	
	Varying chip thickness		Vary feed (Step feed self-vibration cutting)				
	Decrease chip breaking		Vary cutting speed	Pre-groove cutting	Nicks in cutting edge		
	Awkward chip breaking		Reduce breaker width	Add breaker dots to rake face			
			Small Depth of Cut $d < 7\text{mm}$	Large Depth of Cut $d=7-15\text{mm}$	Curl Length l		
			No curl	$l \geq 50\text{mm}$	$l \leq 50\text{mm}$ 1-5 Curl	$\cong 1$ Curl	Less Than 1 Curl Half a Curl
			● Irregular continuous shape ● Tangle around tool and workpiece	● Regular continuous shape ● Long chips	Good	Good	● Chip scattering ● Chattering ● Poor finished surface ● Maximum
			Note				

EFFECTS OF CHIP CONTROL ON PRODUCTIVITY

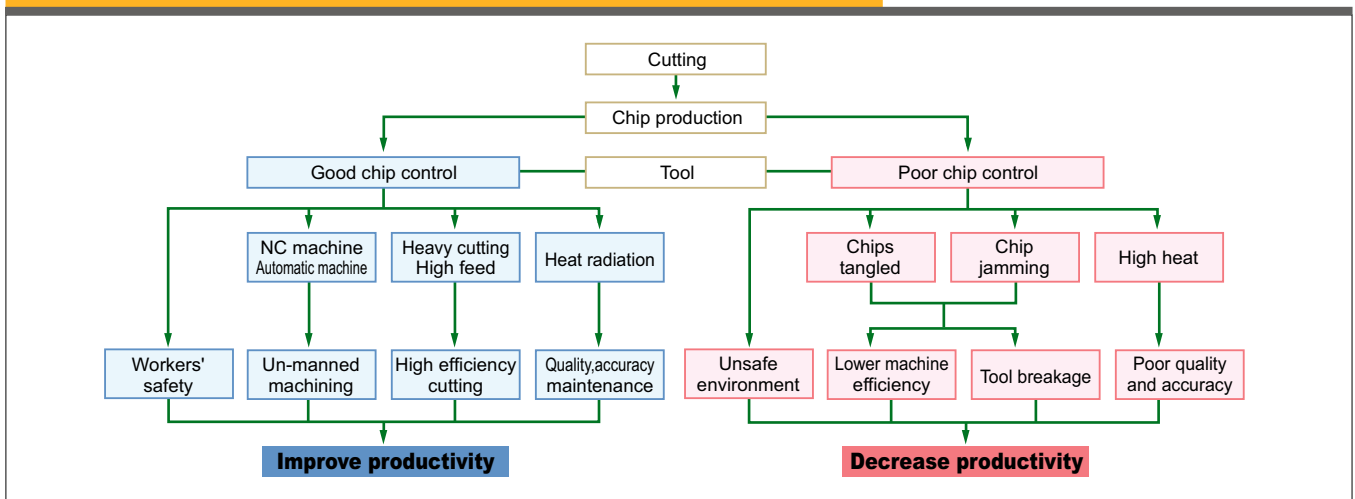

EFFECTS OF CUTTING CONDITIONS FOR TURNING

EFFECTS OF CUTTING CONDITIONS

Ideal conditions for cutting are short cutting time, long tool life, and high cutting accuracy. In order to obtain these conditions, a selection of efficient cutting conditions and tools, based on work material, hardness, shape and machine capability is necessary.

CUTTING SPEED

Cutting speed effects tool life greatly. Increasing cutting speed increases cutting temperature and results in shortening tool life. Cutting speed varies depending on the type and hardness of the work material. Selecting a tool grade suitable for the cutting speed is necessary.

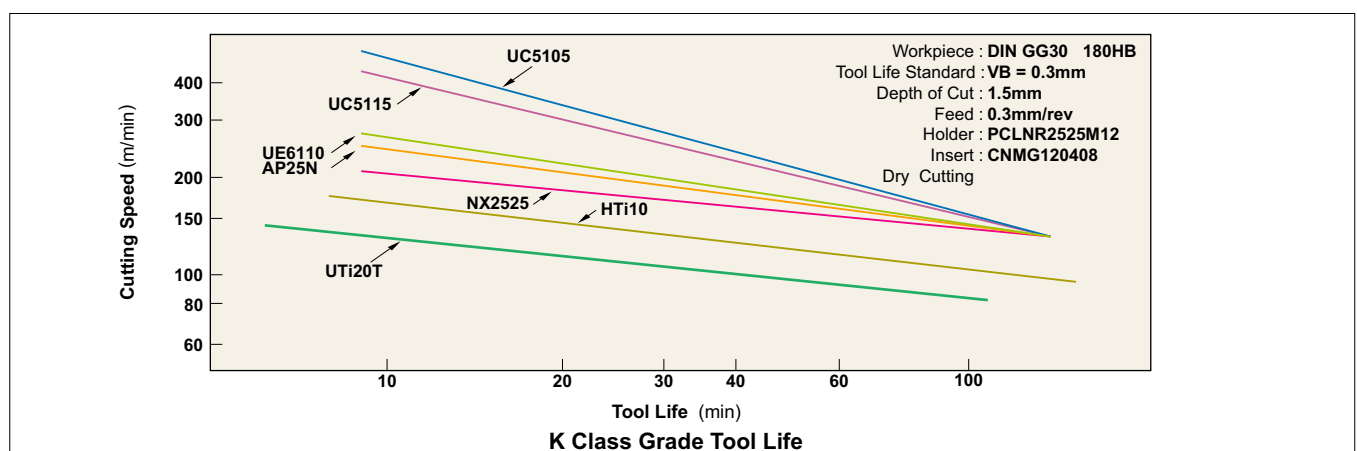
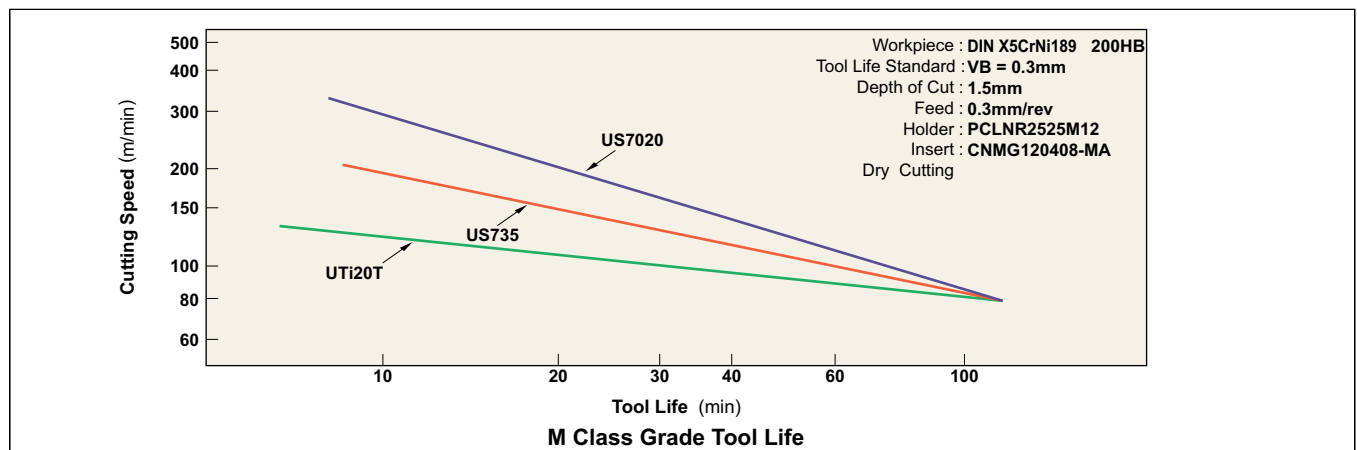
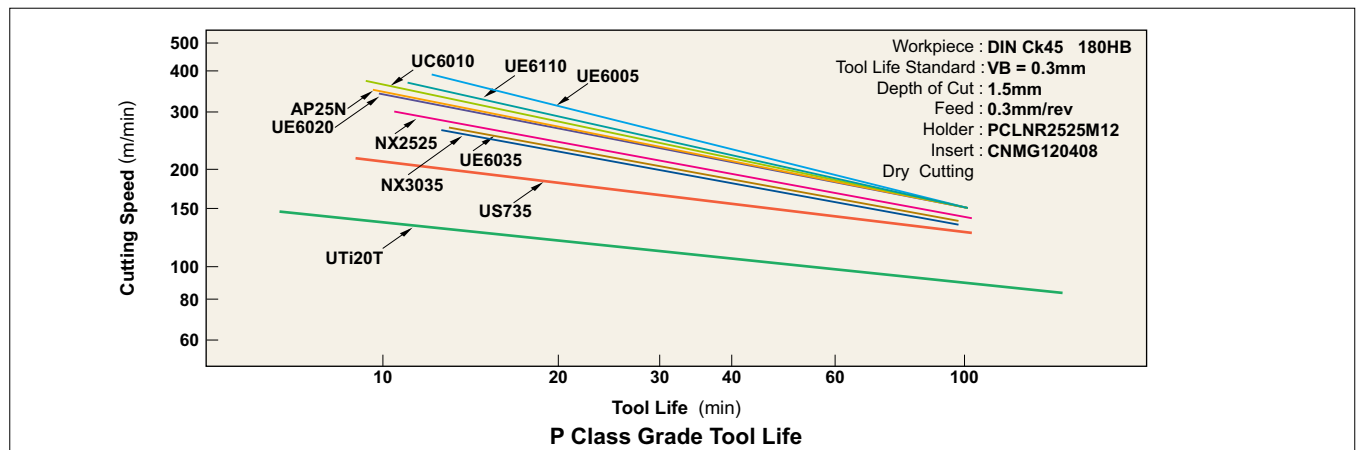

Effects of Cutting Speed

1. Increasing cutting speed by 20% decreases tool life by 50%. Increasing cutting speed by 50% decreases tool life by 80%.
2. Cutting at low cutting speed (20–40m/min) tends to cause chattering. Thus, tool life is shortened.

EFFECTS OF CUTTING CONDITIONS FOR TURNING

FEED

When cutting with a general holder, feed is the distance a holder moves per workpiece revolution. In milling, feed is the distance a machine table moves per cutter revolution divided by number of inserts. Thus, it is indicated as feed per tooth. Feed rate relates to finished surface roughness.

Effects of Feed

1. Decreasing feed rate results in flank wear and shortens tool life.
2. Increasing feed rate increases cutting temperature and flank wear. However, effects on the tool life is minimal compared to cutting speed.
3. Increasing feed rate improves machining efficiency.

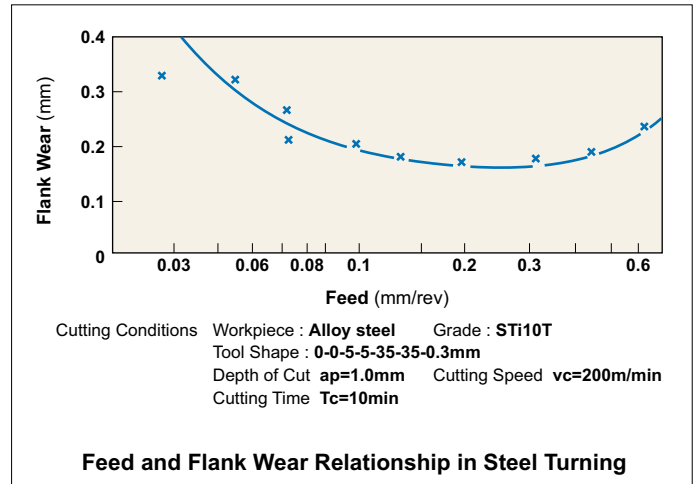

DEPTH OF CUT

Depth of cut is determined according to the required stock removal, shape of workpiece, power and rigidity of the machine and tool rigidity.

Effects of Depth of Cut

1. Changing depth of cut doesn't effect tool life greatly.
2. Small depths of cut result in friction when cutting the hardened layer of a workpiece. Thus tool life is shortened.
3. When cutting uncut surfaces or cast iron surfaces, the depth of cut needs to be increased as much as the machine power allows in order to avoid cutting the impure hard layer with the tip of cutting edge and therefore prevent chipping and abnormal wear.

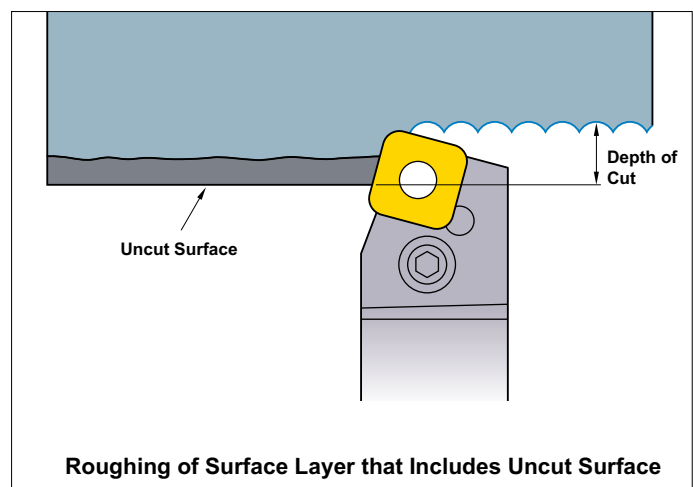
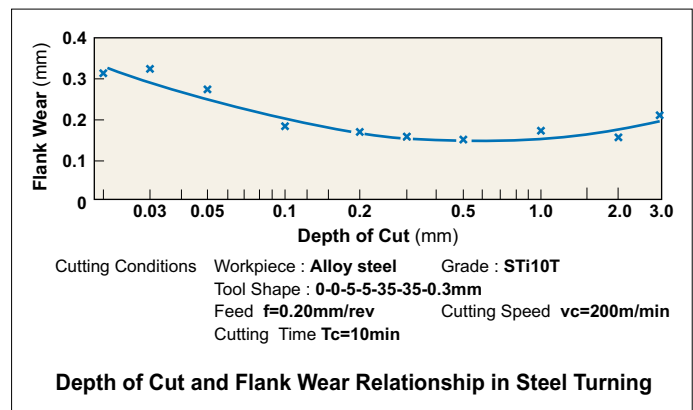

FUNCTION OF TOOL FEATURES FOR TURNING

RAKE ANGLE

Rake angle is the cutting edge angle that has a large effect on cutting resistance, chip disposal, cutting temperature and tool life.

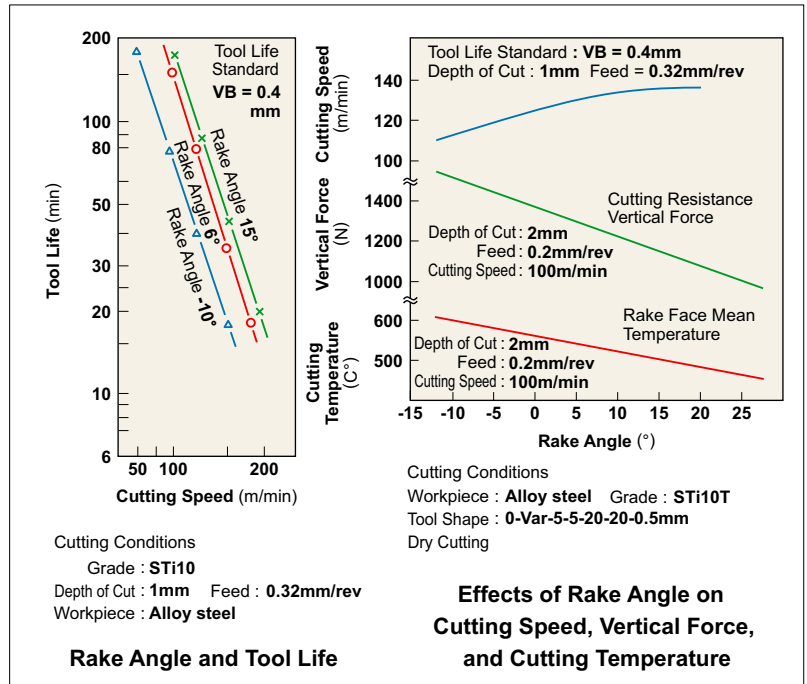
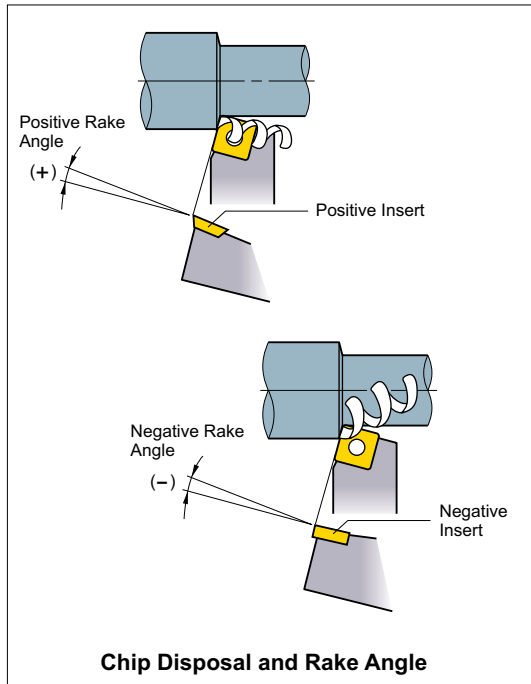

Effects of Rake Angle

1. Increasing rake angle in the positive (+) direction improves sharpness.
2. Increasing rake angle by 1° in the positive (+) direction decreases cutting power by about 1%.
3. Increasing rake angle in the positive (+) direction lowers cutting edge strength and in the negative (-) direction increases cutting resistance.

When to Increase Rake Angle in the Negative (-) Direction

- Hard workpiece.
- When cutting edge strength is required such as in interrupted cutting and uncut surface cutting.

When to Increase Rake Angle in the Positive (+) Direction

- Soft workpiece.
- Workpiece is easily machined.
- When the workpiece or the machine have poor rigidity.

FLANK ANGLE

Flank angle prevents friction between the flank face and workpiece resulting in a smooth feed.

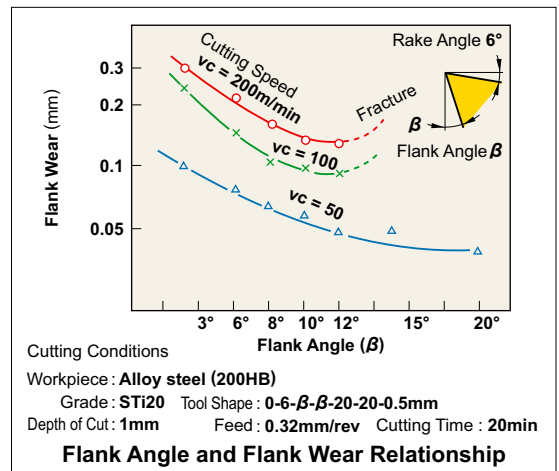
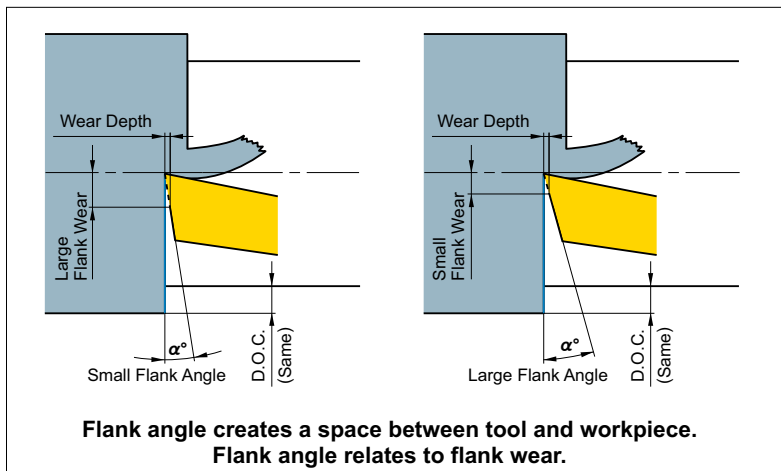

Effects of Flank Angle

1. Increasing flank angle decreases flank wear occurrence.
2. Increasing flank angle lowers cutting edge strength.

When to Decrease Flank Angle

- Hard workpieces.
- When cutting edge strength is required.

When to Increase Flank Angle

- Soft workpieces.
- Workpieces suffer easily from work hardening.

FUNCTION OF TOOL FEATURES FOR TURNING

SIDE CUTTING EDGE ANGLE (LEAD ANGLE)

Side cutting edge angle and corner angle lower impact load and effect feed force, back force, and chip thickness.

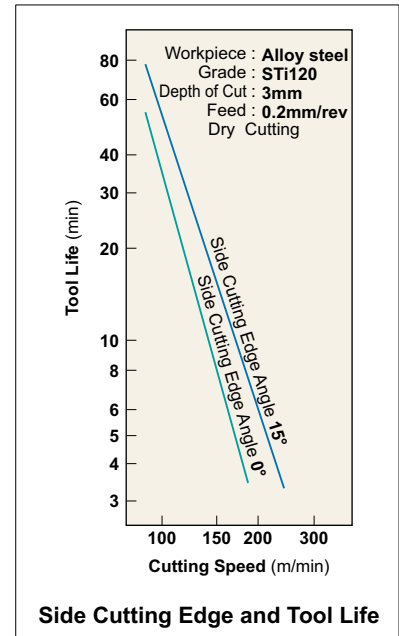
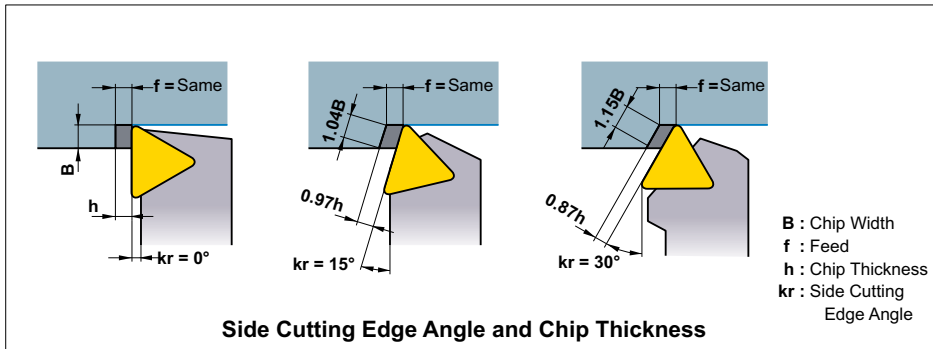

Effects of Side Cutting Edge Angle (Lead Angle)

- At the same feed rate, increasing the side cutting edge angle increases the chip contact length and decreases chip thickness. As a result, the cutting force is dispersed on a longer cutting edge and tool life is prolonged. (Refer to the chart.)
- Increasing the side cutting edge angle increases force a' . Thus, thin, long workpieces can suffer from bending.
- Increasing the side cutting edge angle decreases chip control.
- Increasing the side cutting edge angle decreases the chip thickness and increases chip width. Thus, breaking the chips is difficult.

When to Decrease Lead Angle

- Finishing with small depth of cut.
- Thin, long workpieces.
- When the machine has poor rigidity.

When to Increase Lead Angle

- Hard workpieces which produce high cutting temperature.
- When roughing a large diameter workpiece.
- When the machine has high rigidity.

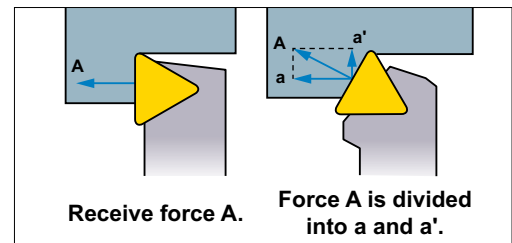

END CUTTING EDGE ANGLE

End cutting edge angle prevents wear on tool and workpiece surface and is usually $5^\circ - 15^\circ$.

Effects of End Cutting Edge Angle

- Decreasing the end cutting edge angle increases cutting edge strength, but it also increases cutting edge temperature.
- Decreasing the end cutting edge angle increases the back force and can result in chattering and vibration while machining.
- Small end cutting edge angle for roughing and a large angle in finishing are recommended.

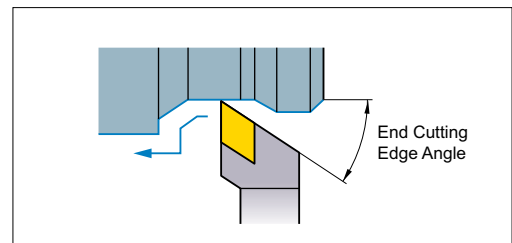

CUTTING EDGE INCLINATION

Cutting edge inclination indicates inclination of the rake face. When heavy cutting, the cutting edge receives an extremely large shock at the beginning of cutting. Cutting edge inclination keeps the cutting edge from receiving this shock and prevents fracturing. $3^\circ - 5^\circ$ in turning and $10^\circ - 15^\circ$ in milling are recommended.

Effects of Cutting Edge Inclination

- Negative (-) cutting edge inclination disposes chips in the workpiece direction, and positive (+) disposes chips in the opposite direction.
- Negative (-) cutting edge inclination increases cutting edge strength, but it also increases back force of cutting resistance. Thus, chattering easily occurs.

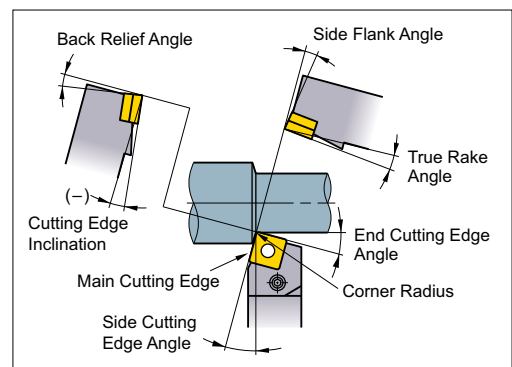

HONING AND LAND

Honing and land are cutting edge shapes that maintain cutting edge strength. Honing can be round or chamfer type. The optimal honing width is approximately 1/2 of the feed.

Land is the narrow flat area on the rake or flank face.

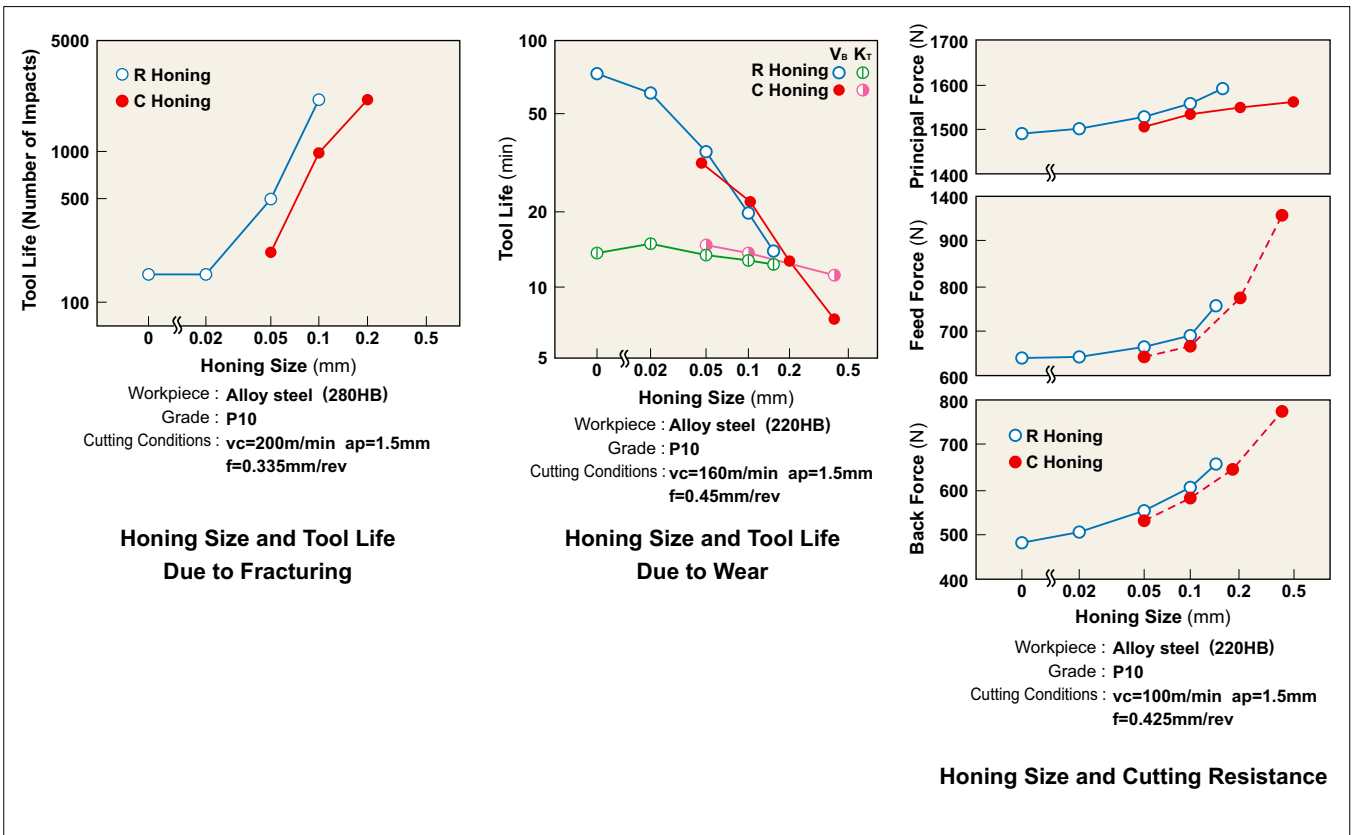
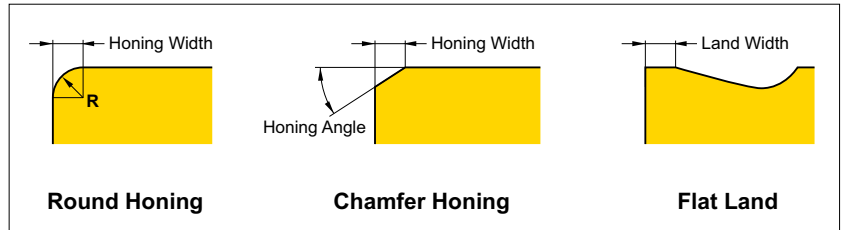

Effects of Honing

1. Enlarging the honing increases cutting edge strength, tool life and reduces fracturing.
2. Enlarging the honing increases flank wear occurrence and shortens tool life. Honing size doesn't affect rake wear.
3. Enlarging the honing increases cutting resistance and chattering.

When to Decrease Honing Size

- When finishing with small depth of cut and small feed.
- Soft workpieces.
- When the workpiece and the machine have poor rigidity.

When to Increase Honing Size

- Hard workpieces.
- When the cutting edge strength is required such as for uncut surface cutting and interrupted cutting.
- When the machine has high rigidity.

*Cemented carbide, UTi, coated diamond and indexable cermet inserts have round honing as standard already.

FUNCTION OF TOOL FEATURES FOR TURNING

RADIUS

Radius effects the cutting edge strength and finished surface. In general, a corner radius 2–3 times the feed is recommended.

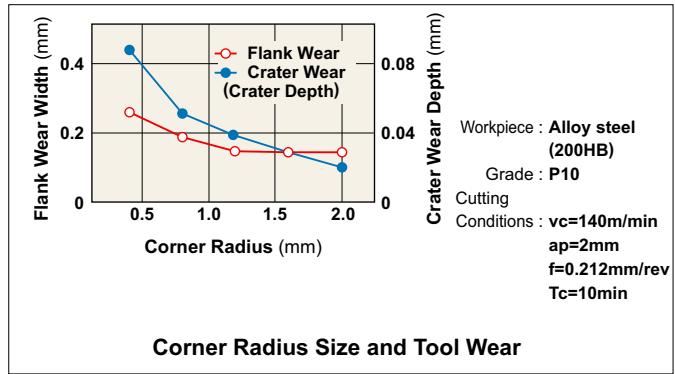
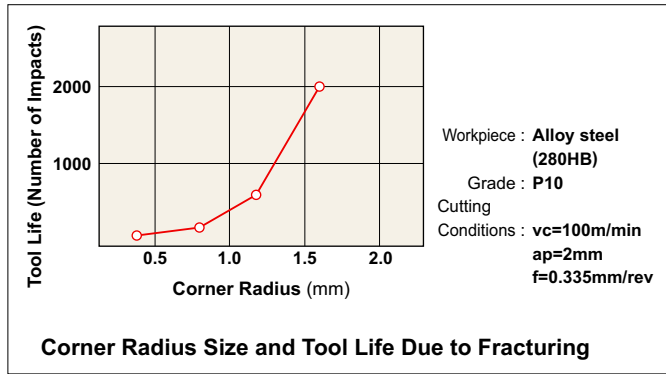
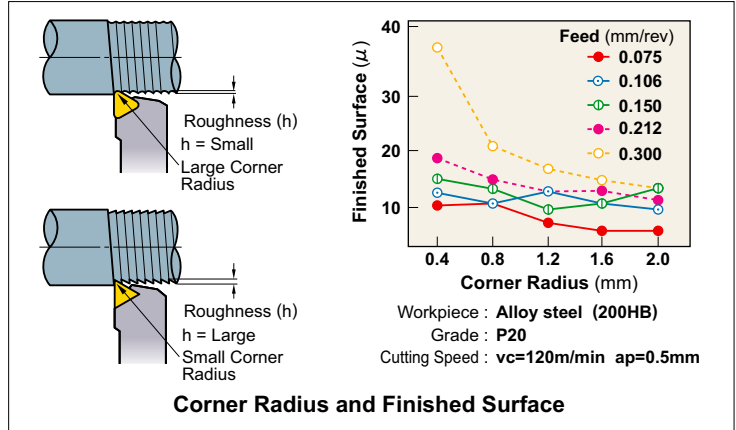

Effects of Corner Radius

1. Increasing the corner radius improves the surface finish.
2. Increasing the corner radius improves cutting edge strength.
3. Increasing the corner radius too much increases the cutting resistance and causes chattering.
4. Increasing the corner radius decreases flank and rake wear.
5. Increasing the corner radius too much results in poor chip control.

When to Decrease Corner Radius

- Finishing with small depth of cut.
- Thin, long workpieces.
- When the machine has poor rigidity.

When to Increase Corner Radius

- When the cutting edge strength is required such as in interrupted cutting and uncut surface cutting.
- When roughing a workpiece with large diameter.
- When the machine has high rigidity.

Corner Radius and Chip Control Range

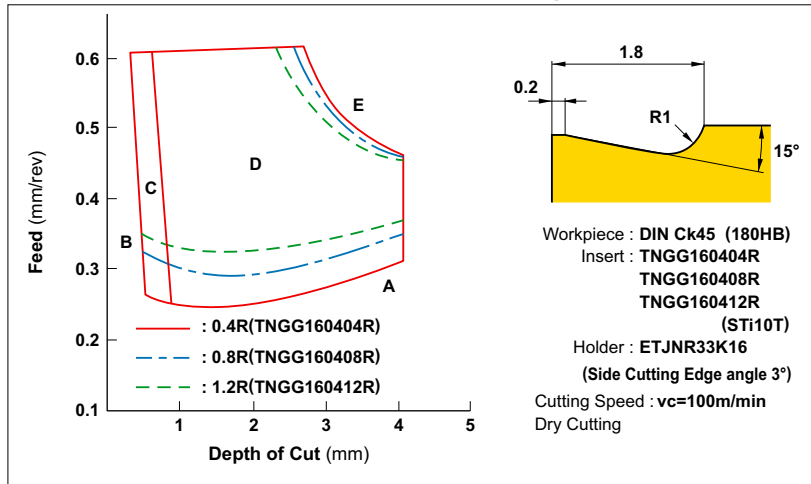

Cutting Speed and Chip Control Range

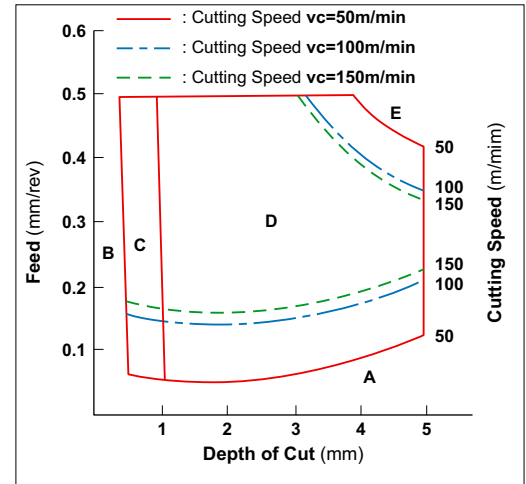

(Note) Please refer to page G008 for chip shapes (A, B, C, D, E).

FORMULAE FOR CUTTING POWER

CUTTING POWER (P_c)

$$P_c = \frac{ap \cdot f \cdot vc \cdot K_c}{60 \times 10^3 \times \eta} \text{ (kW)}$$

P_c (kW) : Actual Cutting Power
 f (mm/rev) : Feed per Revolution
 K_c (N/mm²) : Specific Cutting Force

ap (mm) : Depth of Cut
 vc (m/min) : Cutting Speed
 η : (Machine Coefficient)

(Problem) What is the cutting power required for machining mild steel at cutting speed 120m/min with depth of cut 3mm and feed 0.2mm/rev (Machine coefficient 80%) ?

(Answer) Substitute the specific cutting force $K_c=3100\text{MPa}$ into the formula.

$$P_c = \frac{3 \times 0.2 \times 120 \times 3100}{60 \times 10^3 \times 0.8} = 4.65 \text{ (kW)}$$

K_c

Work Material	Tensile Strength (N/mm ²) and Hardness	Specific Cutting Force K _c (N/mm ²)				
		0.1 (mm/rev)	0.2 (mm/rev)	0.3 (mm/rev)	0.4 (mm/rev)	0.6 (mm/rev)
Mild Steel	520	3610	3100	2720	2500	2280
Medium Steel	620	3080	2700	2570	2450	2300
Hard Steel	720	4050	3600	3250	2950	2640
Tool Steel	670	3040	2800	2630	2500	2400
Tool Steel	770	3150	2850	2620	2450	2340
Chrome Manganese Steel	770	3830	3250	2900	2650	2400
Chrome Manganese Steel	630	4510	3900	3240	2900	2630
Chrome Molybdenum Steel	730	4500	3900	3400	3150	2850
Chrome Molybdenum Steel	600	3610	3200	2880	2700	2500
Nickel Chrome Molybdenum Steel	900	3070	2650	2350	2200	1980
Nickel Chrome Molybdenum Steel	352HB	3310	2900	2580	2400	2200
Hard Cast Iron	46HRC	3190	2800	2600	2450	2270
Meehanite Cast Iron	360	2300	1930	1730	1600	1450
Grey Cast Iron	200HB	2110	1800	1600	1400	1330

CUTTING SPEED (vc)

$$vc = \frac{\pi \cdot Dm \cdot n}{1000} \text{ (m/min)}$$

vc (m/min) : Cutting Speed
 Dm (mm) : Workpiece Diameter
 π (3.14) : Pi
 n (min⁻¹) : Main Axis Spindle Speed

*Divide by 1,000 to change to m from mm.

(Problem) What is the cutting speed when main axis spindle speed is 700min⁻¹ and external diameter is $\phi 50$?

(Answer) Substitute $\pi=3.14$, $Dm=50$, $n=700$ into the formula.

$$vc = \frac{\pi \cdot Dm \cdot n}{1000} = \frac{3.14 \times 50 \times 700}{1000} = 110 \text{ m/min}$$

Cutting speed is 110m/min.

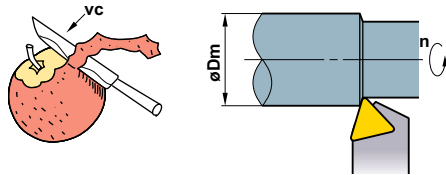

FEED (f)

$$f = \frac{l}{n} \text{ (mm/rev)}$$

f (mm/rev) : Feed per Revolution
 l (mm/min) : Cutting Length per Min.
 n (min⁻¹) : Main Axis Spindle Speed

(Problem) What is the feed per revolution when main axis spindle speed is 500min⁻¹ and cutting length per minute is 120mm/min ?

(Answer) Substitute $n=500$, $l=120$ into the formula.

$$f = \frac{l}{n} = \frac{120}{500} = 0.24 \text{ mm/rev}$$

The answer is 0.24mm/rev.

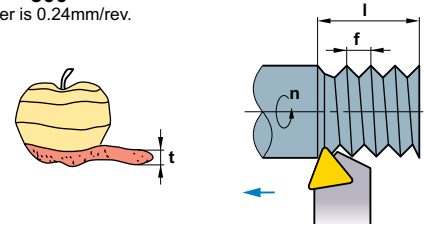

CUTTING TIME (T_c)

$$T_c = \frac{l_m}{l} \text{ (min)}$$

T_c (min) : Cutting Time
 l_m (mm) : Workpiece Length
 l (mm/min) : Cutting Length per Min.

(Problem) What is the cutting time when 100mm workpiece is machined at 1000min⁻¹ with feed = 0.2mm/rev ?

(Answer) First, calculate the cutting length per min. from the feed and spindle speed.

$$l = f \cdot n = 0.2 \times 1000 = 200 \text{ mm/min}$$

Substitute the answer above into the formula.

$$T_c = \frac{l_m}{l} = \frac{100}{200} = 0.5 \text{ min}$$

$0.5 \times 60 = 30$ (sec.) The answer is 30 sec.

THEORETICAL FINISHED SURFACE ROUGHNESS (h)

$$h = \frac{f^2}{8Re} \times 1000 (\mu\text{m})$$

h (μm) : Finished Surface Roughness
 f (mm/rev) : Feed per Revolution
 Re (mm) : Insert Corner Radius

(Problem) What is the theoretical finished surface roughness when the insert corner radius is 0.8mm and feed is 0.2mm/rev ?

(Answer) Substitute $f=0.2\text{mm/rev}$, $R=0.8$ into the formula.

$$h = \frac{0.2^2}{8 \times 0.8} \times 1000 = 6.25 \mu\text{m}$$

The theoretical finished surface roughness is 6 μm .

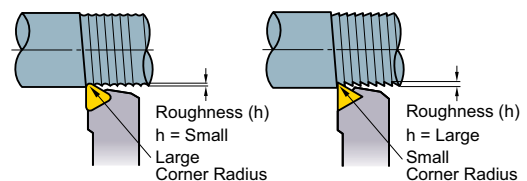

RECOMMENDED CUTTING CONDITIONS FOR FACE MILLING

RECOMMENDED CUTTING CONDITIONS FOR FACE MILLING

Work Material		Recommended Cutting Conditions and Grades				Recommended Cutter	When Recommended Conditions are Insufficient		
		Depth of Cut (mm)	Feed (mm/rev)	Coolant	Recommended Cutting Speed and Grades		Problem/Condition	Countermeasure	
					100 200 300 400				
Mild Steel	≤ 180 HB	Light Cutting	1-3	0.2 (0.1-0.3)	Dry	VP15TF (JL) 250 (200-300)	ASX445	● Easy to fracture. ● Finishing	JM Breaker Wiper Insert
		Medium Cutting	2-5	0.2 (0.1-0.3)	Dry	F7030 (JM) 280 (210-350)	ASX445	● Easy to fracture.	JH Breaker
	180-280 HB	Light Cutting	1-3	0.2 (0.1-0.3)	Dry	VP15TF (JL) 220 (170-270)	ASX445	● Rapid wear occurrence and short tool life.	F7030
		Medium Cutting	2-5	0.2 (0.1-0.3)	Dry	F7030 (JM) 250 (190-310)	ASX445	● Easy to fracture.	JH Breaker
	280-350 HB	Light Cutting	≤ 1.0	0.2 (0.1-0.3)	Dry	VP15TF (JL) 140 (100-180)	ASX445		
		Medium Cutting	1-5	0.2 (0.1-0.3)	Dry	F7030 (JM) 220 (170-270)	ASX445	● Rapid wear occurrence and short tool life.	Lower cutting speed.
Austenitic Stainless Steel	≤ 270 HB	Light Cutting	≤ 1.0	0.2 (0.1-0.3)	Dry	VP15TF (JL) 220 (170-270)	ASX445	● Easy to fracture.	VP30RT
		Medium Cutting	1-5	0.2 (0.1-0.3)	Dry	VP30RT (JM) 200 (150-250)	ASX445	● Easy to fracture.	JH Breaker
High Manganese Steel	200HB		1-4	0.2 (0.1-0.3)	Dry	F7030 (JM) 130 (100-150)	ASX445	● Easy to fracture. ● Finishing	JH Breaker NX4545 (ap ≤ 0.5)
Pure Titanium	≤ 200HB		1-4	0.2 (0.1-0.3)	Oil	VP15TF (JP) 130 (120-140)	ASX445	● Rapid wear occurrence and short tool life.	VP15TF JL Breaker
Titanium Alloy	≤ 350HB		1-3	0.2 (0.1-0.3)	Oil	HTi10 40 (30-60)	SG20	● Rapid wear occurrence and short tool life. ● Second recommendation.	UP20H ASX445
Nickel Base Alloy (Inconel, Waspalloy)			1-3	0.2 (0.1-0.3)	Oil	HTi10 30 (20-40)	SG20	● Second recommendation.	ASX445
Stellite	≤ 35HRC		1-3	0.2 (0.1-0.3)	Dry	HTi10 40 (10-70)	SG20	● Rapid wear occurrence and short tool life. ● Easy to fracture. ● Second recommendation.	vc=15-25m/min Lower depth of cut and feed. ASX445
Die Steel	250-280HB		1-4	0.2 (0.1-0.3)	Dry	VP15TF (JM) 80 (60-100)	ASX445	● Rapid wear occurrence and short tool life. ● Easy to fracture. ● Finishing	Lower cutting speed. JH Breaker NX4545 (ap ≤ 0.5)
	High Speed Steel	50-60HRC	1-3	0.1 (0.05-0.2)	Dry	VP15TF (JH) 60 (40-80)	ASX445	● Easy to fracture.	Lower cutting speed.
Gray Cast Iron	≤ 350 N/mm ²		1-5	0.2 (0.1-0.3)	Dry	F5020 (JM) 200 (150-250)	ASX445	● Easy to fracture.	FT Breaker
Ductile Cast Iron	≤ 450 N/mm ²		1-5	0.2 (0.1-0.3)	Dry	F5020 (JM) 200 (150-250)	ASX445	● Ineffective work conditions. ● Easy to fracture.	VP15TF FT Breaker
	500-800 N/mm ²		1-5	0.2 (0.1-0.3)	Dry	F5020 (JM) 150 (100-200)	ASX445	● Ineffective work conditions. ● Easy to fracture.	VP15TF FT Breaker
Malleable Iron			1-5	0.2 (0.1-0.3)	Dry	VP15TF (JM) 80 (50-100)	ASX445	● Rapid wear occurrence and short tool life.	Lower cutting speed.
Copper Alloy			1-5	0.2 (0.1-0.3)	Mist	HTi10 (JP) 300 (200-400)	ASX445		
Aluminium Alloy			1-5	0.2 (0.1-0.3)	Water Soluble Oil	HTi10 (JP) 650 (300-1000)	ASX445	● Finishing	V 10000 Type Face Milling Cutter. Grade : MD220 vc ≥ 1000

"JL, JM, JP and JH" indicates the chip breaker code.



TROUBLE SHOOTING FOR MILLING

MILLING

Solution		Insert Grade Selection	Cutting Conditions						Style and Design of the Tool					Machine, Installation of Tool										
			Select a harder grade	Select a tougher grade	Select a grade with better thermal shock resistance	Select a grade with better adhesion resistance	Cutting Speed	Feed	Depth of Cut	Cutter diameter and width of cut	Coolant		Rake	Corner Angle	Honing strengthens the cutting edge	Number of Teeth	Wider Chip Pocket	Shape of Minor Cutting Edge	Cutter Run-Out	Cutter Rigidity	Installation of the Tool and Workpiece	Tool Holder Overhang	Machine with Inadequate Power and Rigidity	
											Do not use water-soluble cutting fluid	Determine dry or wet cutting												Up ↗
Trouble	Factors					Up ↗	Down ↘			Up ↗	Down ↘													
		Damage at Cutting Edge	● Extreme Flank Wear	Improper cutting conditions																				
Improper shape of cutting edge	●																							
● Extreme Cratering	Improper cutting conditions																							
	Improper shape of cutting edge		●																					
● Chipping and Fracturing of Cutting Edge	Improper cutting conditions																							
	Improper shape of cutting edge			●																				
● Cracking and Fracturing due to Thermal Shock	Improper cutting conditions																							
	Improper shape of cutting edge			●																				
● Edge Build-up	Improper cutting conditions																							
	Improper shape of cutting edge				●																			
Tolerance	● Poor Finished Surface	Edge wear cutter run-out	●																					
		Improper cutting conditions																						
	● Burrs, Chipping	Improper shape of cutting edge																						
		Improper cutting conditions																						
● Workpiece Edge Chipping	Improper shape of cutting edge																							
	Low stiffness of tool or workpiece																							
Others	● Vibration, Chattering	Severe cutting conditions, workpiece not rigid																						
		Improper cutting conditions																						
● Poor Chip Dispersal, Chip Jamming and Chip Packing	Improper cutting conditions																							
	Improper shape of cutting edge																							

FUNCTION OF TOOL FEATURES FOR FACE MILLING

FUNCTION OF EACH CUTTING EDGE ANGLE IN FACE MILLING

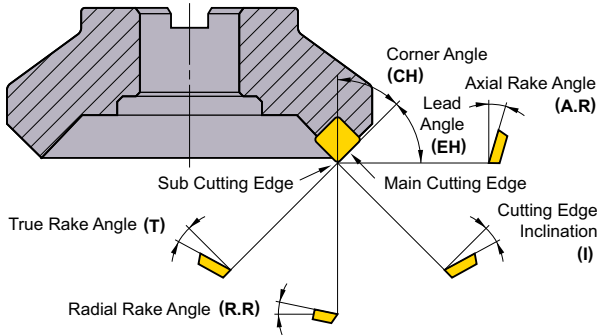

Each Cutting Edge Angle in Face Milling

Type of Angle	Symbol	Function	Effect
Axial Rake Angle	A.R	Determines chip disposal direction.	Positive : Excellent machinability.
Radial Rake Angle	R.R	Determines sharpness.	Negative : Excellent chip disposal.
Corner Angle	CH	Determines chip thickness.	Large : Thin chips and small cutting impact. Large back force.
True Rake Angle	T	Determines actual sharpness.	Positive (large) : Excellent machinability. Minimal welding. Negative (large) : Poor machinability. Strong cutting edge.
Cutting Edge Inclination	I	Determines chip disposal direction.	Positive (large) : Excellent chip disposal. Low cutting edge strength.

STANDARD INSERTS

Positive and Negative Rake Angle

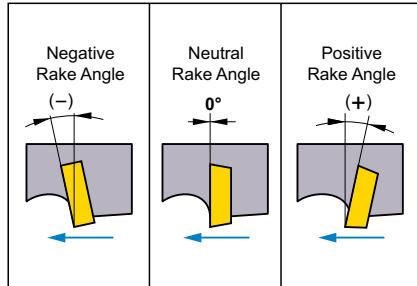

- Insert shape whose cutting edge precedes is a positive rake angle.
- Insert shape whose cutting edge follows is a negative rake angle.

Standard Cutting Edge Shape

Standard Cutting Edge Combinations	(+) Axial Rake Angle	(-) Axial Rake Angle	(+) Axial Rake Angle	
		Radial Rake Angle (+)	Radial Rake Angle (-)	Radial Rake Angle (-)
	Double Positive (DP Edge Type)	Double Negative (DN Edge Type)	Negative/Positive (NP Edge Type)	
Axial Rake Angle (A.R.)	Positive (+)	Negative (-)	Positive (+)	
Radial Rake Angle (R.R.)	Positive (+)	Negative (-)	Negative (-)	
Insert Used	Positive Insert (One Sided Use)	Negative Insert (Double Sided Use)	Positive Insert (One Sided Use)	
Work Material	Steel	●	-	●
	Cast Iron	-	●	●
	Aluminium Alloy	●	-	-
	Difficult-to-Cut Material	●	-	●

CORNER ANGLE (CH) AND CUTTING CHARACTERISTICS

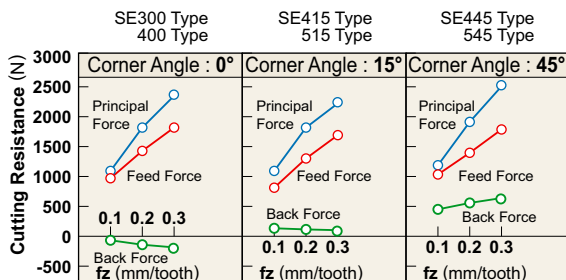

Workpiece : DIN 41CrMo4 (281HB)
Tool : $\phi 125\text{mm}$ Single Insert
Cutting Conditions : $vc=125.6\text{m/min}$ $ap=4\text{mm}$ $ae=110\text{mm}$

Cutting Resistance Comparison between Different Insert Shapes

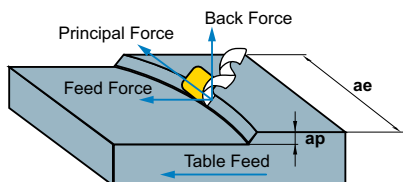

Three Cutting Resistance Forces in Milling

Corner Angle 45°

The largest back force. Bends thin workpieces and lowers cutting accuracy.
*Prevents workpiece edge chipping when cast iron cutting.

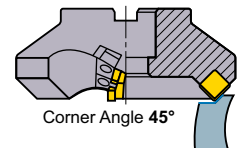

Corner Angle 0°

Back force is in the minus direction. Lifts the workpiece when workpiece clamp rigidity is low.

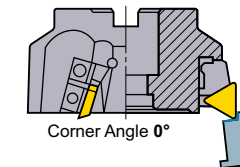

Corner Angle 15°

Corner angle 15° is recommended for face milling of workpieces with low rigidity such as thin workpieces.

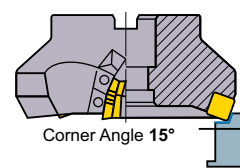

- * Principal force : Force is in the opposite direction of face milling rotation.
- * Back force : Force that pushes in the axial direction.
- * Feed force : Force is in the feed direction and is caused by table feed.

FINISHED SURFACE

Cutting Edge Run-out Accuracy

Cutting edge run-out accuracy of indexable inserts on the cutter body greatly affects the surface finish and tool life.

```

    graph LR
      Run-out -- Large --> Poor[Poor Finished Surface]
      Run-out -- Small --> Good[Good Finished Surface]
      Poor --> Chipping[Chipping Due to Vibration]
      Poor --> Wear[Rapid Wear Growth]
      Chipping --> Shorten[Shorten Tool Life]
      Wear --> Shorten
      Good --> Stable[Stable Tool Life]
    
```

Face Milling Run-out Accuracy
 Minor Cutting Edge $\leq 0.03\text{mm}$
 Peripheral Cutting Edge $\leq 0.05\text{mm}$

Cutting Edge Run-out and Accuracy in Face Milling

Improve Finished Surface Roughness

Since Mitsubishi Materials' normal sub cutting edge width is 1.4mm, and the sub cutting edges are set parallel to the face of a milling cutter, theoretically the finished surface accuracy should be maintained even if run-out accuracy is low.

Actual Problems

- Cutting edge run-out.
- Sub cutting edge inclination.
- Milling cutter body accuracy.
- Spare parts accuracy.
- Welding, vibration, chattering.

Countermeasure

Wiper Insert

★ Machine a surface that has already been machined with normal inserts in order to produce a smooth finished surface.

Replace one or two normal inserts with wiper inserts.
 Wiper inserts are set to protrude by 0.03—0.1mm from the standard inserts.

Sub Cutting Edge Run-out and Finished Surface

fz : Feed per Tooth
 f : Feed per Revolution

How to Set a Wiper Insert

· Sub cutting edge length has to be longer than the feed per revolution.
 ★ Too long sub cutting edge causes chattering.
 · When the cutter diameter is large and feed per revolution is longer than the sub cutting edge of the wiper insert, use two or three wiper inserts.
 · When using more than 1 wiper insert, run-out needs to be eliminated.
 · Use a high hardness grade (high wear resistance) for wiper inserts.

(a) **One Corner Type**
Replace normal insert.

(b) **Two Corner Type**
Replace normal insert.

(c) **Two Corner Type**
Use locator for wiper insert.

FORMULAE FOR MILLING

CUTTING SPEED (vc)

$$v_c = \frac{\pi \cdot D_1 \cdot n}{1000} \text{ (m/min)}$$

v_c (m/min) : Cutting Speed
 π (3.14) : Pi

D_1 (mm) : Cutter Diameter
 n (min⁻¹) : Main Axis Spindle Speed

*Divide by 1,000 to change to m from mm.

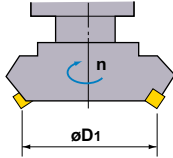

(Problem) What is the cutting speed when the main axis spindle speed is 350min⁻¹ and the cutter diameter is ϕ 125 ?

(Answer) Substitute $\pi=3.14$, $D_1=125$, $n=350$ into the formula.

$$v_c = \frac{\pi \cdot D_1 \cdot n}{1000} = \frac{3.14 \times 125 \times 350}{1000} = 137.4 \text{ m/min}$$

The cutting speed is 137.4m/min.

FEED PER TOOTH (fz)

$$f_z = \frac{v_f}{z \cdot n} \text{ (mm/tooth)}$$

f_z (mm/tooth) : Feed per Tooth

z : Insert Number

v_f (mm/min) : Table Feed per Min.

n (min⁻¹) : Main Axis Spindle Speed (Feed per Revolution $f = z \times f_z$)

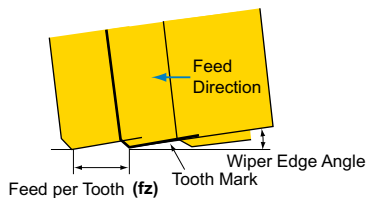

(Problem) What is the feed per tooth when the main axis spindle speed is 500min⁻¹, insert number is 10, and the table feed is 500mm/min ?

(Answer) Substitute the above figures into the formula.

$$f_z = \frac{v_f}{z \cdot n} = \frac{500}{10 \times 500} = 0.1 \text{ mm/tooth}$$

The answer is 0.1mm/tooth.

TABLE FEED (vf)

$$v_f = f_z \cdot z \cdot n \text{ (mm/min)}$$

v_f (mm/min) : Table Feed per Min.

z : Insert Number

f_z (mm/tooth) : Feed per Tooth

n (min⁻¹) : Main Axis Spindle Speed

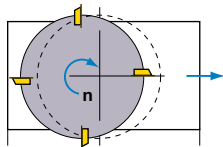

(Problem) What is the table feed when feed per tooth is 0.1mm/tooth, insert number is 10, and the main axis spindle speed is 500min⁻¹?

(Answer) Substitute the above figures into the formula.

$$v_f = f_z \cdot z \cdot n = 0.1 \times 10 \times 500 = 500 \text{ mm/min}$$

The table feed is 500mm/min.

CUTTING TIME (Tc)

$$T_c = \frac{L}{v_f} \text{ (min)}$$

T_c (min) : Cutting Time

v_f (mm/min) : Table Feed per Min.

L (mm) : Total Table Feed Length (Workpiece Length: I+Cutter Diameter : D_1)

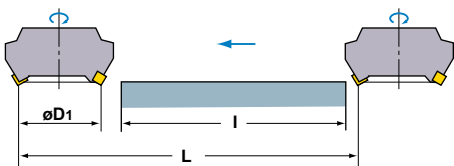

(Problem) What is the cutting time required for finishing 100mm width and 300mm length surface of a cast iron (GG20) block when the cutter diameter is ϕ 200, the number of inserts is 16, the cutting speed is 125m/min, and feed per tooth is 0.25mm. (spindle speed is 200min⁻¹)

(Answer) Calculate table feed per min $v_f=0.25 \times 16 \times 200=800$ mm/min
 Calculate total table feed length. $L=300+200=500$ mm
 Substitute the above answers into the formula.

$$T_c = \frac{500}{800} = 0.625 \text{ (min)}$$

$0.625 \times 60=37.5$ (sec). The answer is 37.5 sec.

CUTTING POWER (Pc)

$$P_c = \frac{a_p \cdot a_e \cdot v_f \cdot K_c}{60 \times 10^6 \cdot \eta}$$

P_c (kW) : Actual Cutting Power
a_e (mm) : Cutting Width
K_c (N/mm²) : Specific Cutting Force

a_p (mm) : Depth of Cut
v_f (mm/min) : Table Feed per Min.
η : (Machine Coefficient)

(Problem) What is the cutting power required for milling tool steel at a cutting speed of 80m/min. With depth of cut 2mm, cutting width 80mm, and table feed 280mm/min by ϕ 250 cutter with 12 inserts. Machine coefficient 80%.

(Answer) First, calculate the spindle speed in order to obtain the feed per tooth.

$$n = \frac{1000vc}{\pi D_1} = \frac{1000 \times 80}{3.14 \times 250} = 101.91 \text{ min}^{-1}$$

$$\text{Feed per Tooth } fz = \frac{vf}{z \times n} = \frac{280}{12 \times 101.9} = 0.228 \text{ mm/tooth}$$

Substitute the specific cutting force into the formula.

$$P_c = \frac{2 \times 80 \times 280 \times 1800}{60 \times 10^6 \times 0.8} = 1.68 \text{ kW}$$

K_c

Work Material	Tensile Strength (N/mm ²) and Hardness	Specific Cutting Force K _c (N/mm ²)				
		0.1mm/tooth	0.2mm/tooth	0.3mm/tooth	0.4mm/tooth	0.6mm/tooth
Mild Steel	520	2200	1950	1820	1700	1580
Medium Steel	620	1980	1800	1730	1600	1570
Hard Steel	720	2520	2200	2040	1850	1740
Tool Steel	670	1980	1800	1730	1700	1600
Tool Steel	770	2030	1800	1750	1700	1580
Chrome Manganese Steel	770	2300	2000	1880	1750	1660
Chrome Manganese Steel	630	2750	2300	2060	1800	1780
Chrome Molybdenum Steel	730	2540	2250	2140	2000	1800
Chrome Molybdenum Steel	600	2180	2000	1860	1800	1670
Nickel Chrome Molybdenum Steel	940	2000	1800	1680	1600	1500
Nickel Chrome Molybdenum Steel	352HB	2100	1900	1760	1700	1530
Cast Iron	520	2800	2500	2320	2200	2040
Hard Cast Iron	46HRC	3000	2700	2500	2400	2200
Meehanite Cast Iron	360	2180	2000	1750	1600	1470
Grey Cast Iron	200HB	1750	1400	1240	1050	970
Brass	500	1150	950	800	700	630
Light Alloy (Al-Mg)	160	580	480	400	350	320
Light Alloy (Al-Si)	200	700	600	490	450	390

TROUBLE SHOOTING FOR END MILLING

END MILLING

Solution / Trouble		Insert Grade Selection	Cutting Conditions						Style and Design of the Tool			Machine, Installation of Tool								
		Coated Tool	Cutting Speed		Feed	Depth of Cut	Coolant	Helix Angle	Insert Number	Tool Diameter	Shorten tool overhang	Tool Installation Accuracy	Spindle Collet Run-out Accuracy	Collet Inspection and Exchange	Increase chuck clamping power	Machine Stability, Rigidity				
			Up ↗	Down ↘													Down Cut	Increase coolant quantity	Do not use water-soluble cutting fluid	Determine dry or wet cutting
Damage on the Body	● End mill Breakage			● ↘	● ↘				● ↘	● ↗	●		●	●						
Damage at Cutting Edge	● Rapid Cutting Edge Wear	●	● ↘	● ↗		Down Cut		●		● ↗										
	● Chipping		● ↘	● ↘	● ↘	Down Cut		● Dry			●	●	●		●					
	● Chip Welding	●					●	● Wet	● ↗											
Tolerance	● Poor Finished Surface		● ↗	● ↘	● ↘			● Wet			●									
	● Waviness			● ↘	● ↘				● ↘	● ↗	● ↗	●		●						
	● Out of Vertical			● ↘	● ↘	Up Cut		●	● ↗	● ↗	● ↗	●								
	● Burr, Workpiece Chipping			● ↘	● ↘				● ↘											
	● Chattering		● ↘	● ↗					● ↗	● ↘	● ↗	●		●	●	●				
Chip Control	● Poor Chip Disposal			● ↘	● ↘		●			● ↘										
Others		<p>(1) When the cutting wear is over the maximum, fracturing of the endmill or deterioration of the surface accuracy can occur. In such cases, early re-grinding is recommended.</p> <p>(2) It is effective in solving all problems to minimize the length of a cutting edge or to employ higher rigidity with no deflection.</p>																		

TROUBLE SHOOTING FOR END MILLING



PITCH SELECTION OF PICK FEED

PICK FEED MILLING (CONTOURING) WITH BALL NOSE END MILLS AND END MILLS WITH CORNER RADII

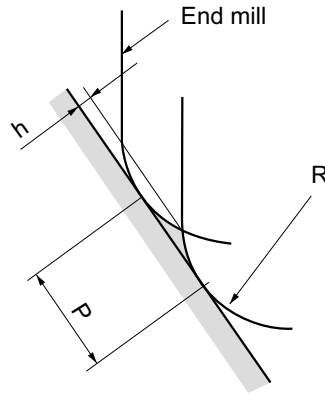

$$h = R \cdot \left[1 - \cos \left\{ \sin^{-1} \left(\frac{P}{2R} \right) \right\} \right]$$

R : Radius of Ball Nose, Corner Radius

P : Pick Feed

h : Cusp Height

CORNER R OF END MILLS AND CUSP HEIGHT BY PICK FEED

Unit : mm

R \ P	Pitch of Pick Feed (P)									
	0.1	0.2	0.3	0.4	0.5	0.6	0.7	0.8	0.9	1.0
0.5	0.003	0.010	0.023	0.042	0.067	0.100	–	–	–	–
1	0.001	0.005	0.011	0.020	0.032	0.046	0.063	0.083	0.107	–
1.5	0.001	0.003	0.008	0.013	0.021	0.030	0.041	0.054	0.069	0.086
2	0.001	0.003	0.006	0.010	0.016	0.023	0.031	0.040	0.051	0.064
2.5	0.001	0.002	0.005	0.008	0.013	0.018	0.025	0.032	0.041	0.051
3		0.002	0.004	0.007	0.010	0.015	0.020	0.027	0.034	0.042
4		0.001	0.003	0.005	0.008	0.011	0.015	0.020	0.025	0.031
5		0.001	0.002	0.004	0.006	0.009	0.012	0.016	0.020	0.025
6		0.001	0.002	0.003	0.005	0.008	0.010	0.013	0.017	0.021
8			0.001	0.003	0.004	0.006	0.008	0.010	0.013	0.016
10			0.001	0.002	0.003	0.005	0.006	0.008	0.010	0.013
12.5			0.001	0.002	0.003	0.004	0.005	0.006	0.008	0.010

R \ P	Pitch of Pick Feed (P)									
	1.1	1.2	1.3	1.4	1.5	1.6	1.7	1.8	1.9	2.0
0.5	–	–	–	–	–	–	–	–	–	–
1	–	–	–	–	–	–	–	–	–	–
1.5	0.104	–	–	–	–	–	–	–	–	–
2	0.077	0.092	0.109	–	–	–	–	–	–	–
2.5	0.061	0.073	0.086	0.100	–	–	–	–	–	–
3	0.051	0.061	0.071	0.083	0.095	0.109	–	–	–	–
4	0.038	0.045	0.053	0.062	0.071	0.081	0.091	0.103	–	–
5	0.030	0.036	0.042	0.049	0.057	0.064	0.073	0.082	0.091	0.101
6	0.025	0.030	0.035	0.041	0.047	0.054	0.061	0.068	0.076	0.084
8	0.019	0.023	0.026	0.031	0.035	0.040	0.045	0.051	0.057	0.063
10	0.015	0.018	0.021	0.025	0.028	0.032	0.036	0.041	0.045	0.050
12.5	0.012	0.014	0.017	0.020	0.023	0.026	0.029	0.032	0.036	0.040

END MILL FEATURES AND SPECIFICATION

NOMENCLATURE

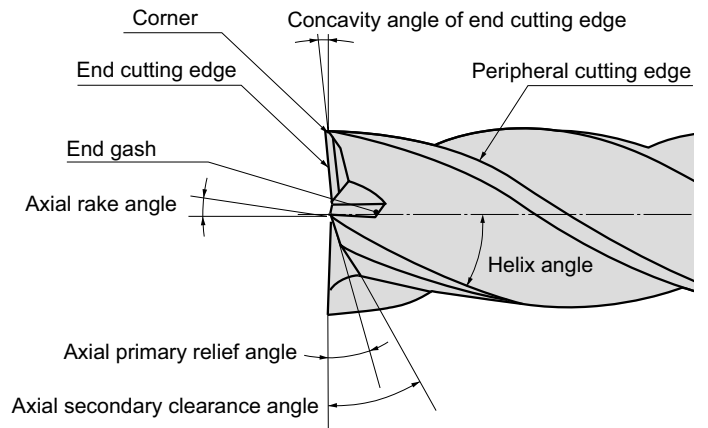
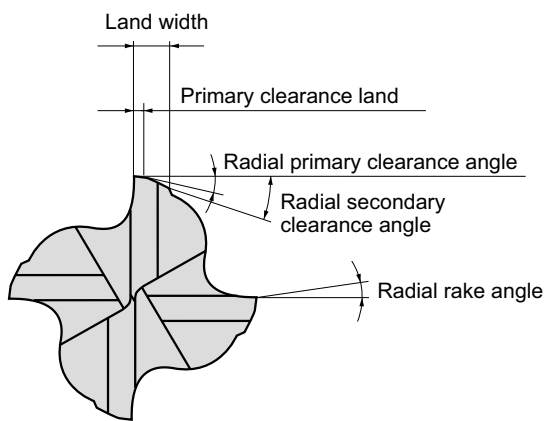
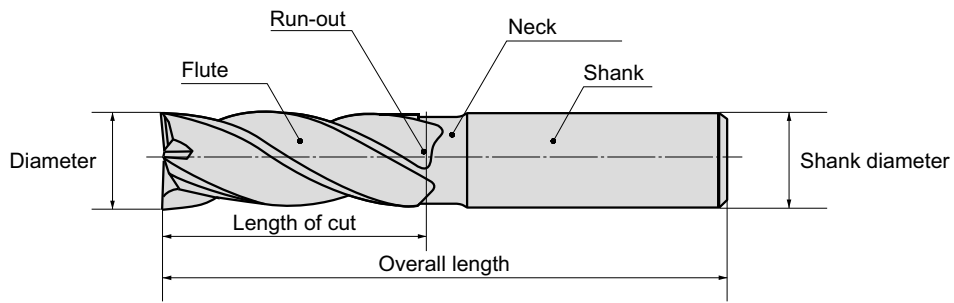

NUMBER OF FLUTES OF END MILL

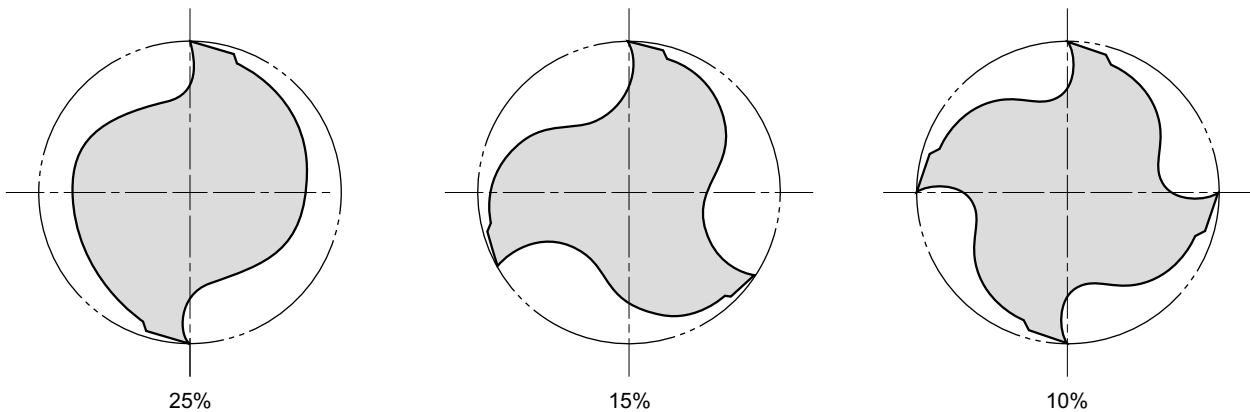





Comparison of Sectional Shape Area of Chip Pocket

Features of Flute and Chip Pocket



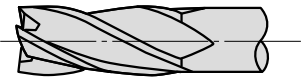

	2-flutes	3-flutes	4-flutes
Feature	Advantage Chip disposability is excellent. Drilling is easy.	Advantage Chip disposability is excellent. Suitable for sinking.	Advantage High rigidity
	Fault Low rigidity	Fault Diameter is not measured easily.	Fault Chip disposability is bad.
Usage	Slotting, side milling, sinking. Wide range of use.	Slotting, side milling Heavy cutting, finishing	Shallow slotting, side milling Finishing

TYPE AND GEOMETRY

(1) Peripheral Cutting Edge

Type	Shape	Feature
Ordinary Flute		Regular flute geometry as shown is most commonly used for roughing and finishing of side milling, slotting and shoulder milling.
Tapered Flute		A tapered flute geometry is used for special applications such as mould drafts and for applying taper angles after conventional straight edged milling.
Roughing Flute		Roughing type geometry has a wave like edge form and breaks the material into small chips. Additionally the cutting resistance is low enabling high feed rates when roughing. The inside face of the flute is suitable for regrinding.
Formed Flute		Special form geometry as shown is used for producing corner radii on components. There are an infinite number of different geometries that can be manufactured using such style of cutters.

(2) End Cutting Edge

Type	Shape	Feature
Square End (With Centre Hole)		Generally used for side milling, slotting and shoulder milling. Plunge cutting is not possible due to the centre hole that is used to ensure accurate grinding and regrinding of the tool.
Square End (Centre Cut)		Generally used for side milling, slotting and shoulder milling. Plunge cutting is possible and greater plunge cutting efficiency is obtained when using fewer flutes. Regrinding on the flank face can be done.
Ball End		Geometry completely suited for curved surface milling. At the extreme end point the chip pocket is very small leading to inefficient chip evacuation.
Corner Radius End		Used for radius profiling and corner radius milling. When pick feed milling an end mill with a large diameter and small corner radius can be efficiently used.

(3) Shank And Neck Parts

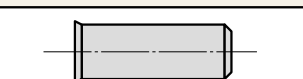
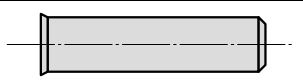
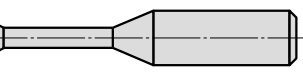
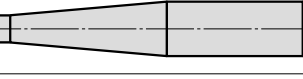
Type	Shape	Feature
Standard (Straight Shank)		Most widely used type.
Long Shank		Long shank type for deep pocket and shoulder applications.
Long Neck		Long neck geometry can be used for deep slotting and is also suitable for boring.
Taper Neck		Long taper neck features are best utilised on deep slotting and mould draft applications.

TROUBLE SHOOTING FOR DRILLING

DRILLING

Solution / Trouble		Cutting Conditions							Style and Design of the Tool							Machine, Installation of Tool							
		Cutting Speed		Feed	Lower feed at initial cutting	Lower feed when breaking through	Step feed	Coolant			Point Angle	Flank Angle	Back Taper	Land Width	Honing Width	Core Thickness	Body Diameter	Groove Length (Overhang)	Tool installation accuracy	Shorten tool overhang	Flat workpiece face	Workpiece installed securely	Machine Stability, Rigidity
		Up ↗	Down ↘					Increase oil ratio	Increase volume	Increase coolant pressure													
Damage on the Body	● Drill Breakage		● ↘														●		●		●		
	● Abnormal Scratches on the Body		● ↘													● ↘			●				
Damage at Cutting Edge	● Chisel Edge Fracture			●									● ↗						●				
	● Shoulder Fracture				●								● ↗				●						
	● Chipping		● ↘				●						● ↗					●		●			
	● Thermal Crack	● ↘	● ↘					●	●			● ↗	● ↘	● ↗									
	● Flaking along land						●				● ↗												
	● Abnormal Wear along land	● ↘					●	●									●						
	● Abnormal Wear at Centre	● ↘					●	●															
Chip	● Chip Jamming	● ↘	● ↘			●	●	●							● ↘								
	● Long Chips	● ↘	● ↗				●						● ↘										
	● Chip Discoloration	● ↘					●																
Hole Accuracy	● Large Over Size			●						● ↘				● ↘	● ↗	●	●						
	● Poor Surface Roughness	● ↗	● ↘	●			●			● ↘		● ↘	●					●					
	● Poor Roundness	● ↗		●						● ↘	● ↗		● ↘			●	●						
	● Bent, not Vertical			●		●					● ↗	●				●		●	●				
	● Burring		● ↘		●					● ↗			● ↘										
Others	● Chattering, Vibration		● ↘										● ↘					●	●	●	●		
	● Abnormal Noise	● ↘									● ↗	●											

TROUBLE SHOOTING FOR DRILLING



TECHNICAL DATA

FORMULAE FOR DRILLING

CUTTING SPEED (vc)

$$vc = \frac{\pi \cdot D_1 \cdot n}{1000} \text{ (m/min)}$$

vc (m/min) : Cutting Speed
 π (3.14) : Pi

D1 (mm) : Drill Diameter
 n (min⁻¹) : Rotational Speed of the Main Spindle

*Unit transformation (from "mm" to "m")

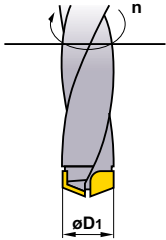

(Problem) What is the cutting speed when the main axis spindle speed is 1350min⁻¹ and drill diameter is 12mm ?

(Answer) Substitute $\pi=3.14$, $D_1=12$, $n=1350$ into the formula

$$vc = \frac{\pi \cdot D_1 \cdot n}{1000} = \frac{3.14 \times 12 \times 1350}{1000} = 50.9 \text{ m/min}$$

The cutting speed is 50.9m/min.

FEED OF THE MAIN SPINDLE (vf)

$$vf = f \cdot n \text{ (mm/min)}$$

vf (mm/min) : Feed Speed of the Main Spindle (Z axis)
 f (mm/rev) : Feed per Revolution
 n (min⁻¹) : Rotational Speed of the Main Spindle

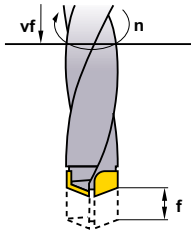

(Problem) What is the spindle feed (vf) when the feed per revolution is 0.2mm/rev and the main axis spindle speed is 1350min⁻¹ ?

(Answer) Substitute $f=0.2$, $n=1350$ into the formula

$$vf = f \cdot n = 0.2 \times 1350 = 270 \text{ mm/min}$$

The spindle feed is 270mm/min.

DRILLING TIME (Tc)

$$T_c = \frac{ld \cdot i}{n \cdot f}$$

Tc (min) : Drilling Time
 n (min⁻¹) : Spindle Speed
 ld (mm) : Hole Depth
 f (mm/rev) : Feed per Revolution
 i : Number of Holes

(Problem) What is the drilling time required for drilling a 30mm length hole in alloy steel at a cutting speed of 50m/min and a feed 0.15mm/rev ?

(Answer) Spindle Speed $n = \frac{50 \times 1000}{15 \times 3.14} = 1061.57 \text{ min}^{-1}$

$$T_c = \frac{30 \times 1}{1061.57 \times 0.15} = 0.188$$

$$= 0.188 \times 60 \approx 11.3 \text{ sec}$$

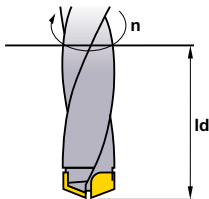

DRILL FEATURES AND SPECIFICATION

NOMENCLATURE

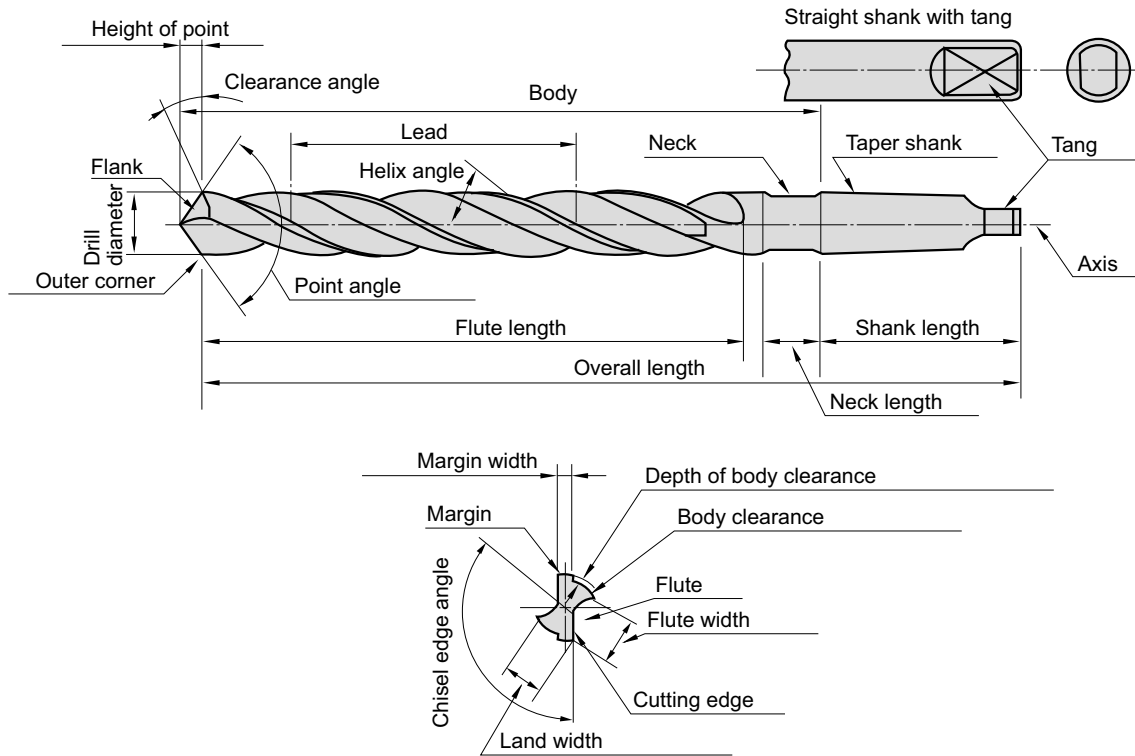

DRILL FEATURES AND SPECIFICATION

TECHNICAL DATA

SHAPE SPECIFICATION AND CUTTING CHARACTERISTICS

Helix Angle	<p>It is the inclination of the flute with respect to the axial direction of a drill, which corresponds to the rake angle of a bit. The rake angle of a drill differs according to the position of the cutting edge, and it decreases greatly as the circumference approaches the centre.</p> <p>High-hardness material Small ◀◀ Rake angle ▶▶ Large Soft material (Aluminium, etc.)</p>			
Flute Length	<p>It is determined by depth of hole, bush length, and regrinding allowance. Since the influence on the tool life is great, it is necessary to minimize it as much as possible.</p>			
Point Angle	<p>In general, the angle is 118°, which is set according to applications.</p> <p>Soft material with good machinability Small ◀◀ Point angle ▶▶ Large For hard material and high-efficiency machining</p>			
Web Thickness	<p>It is an important element that determines the rigidity and chip breaking performance of a drill. The web thickness is set according to applications.</p> <p> <table style="display: inline-table; border: none;"> <tr> <td style="border: none;"> Small cutting resistance Low rigidity Good chip raking performance Machinable material </td> <td style="border: none; vertical-align: middle;"> } Thin ◀◀ Web thickness ▶▶ Thick </td> <td style="border: none;"> { Large cutting resistance High rigidity Poor chip raking performance High-hardness material, cross hole drilling, etc. </td> </tr> </table> </p>	Small cutting resistance Low rigidity Good chip raking performance Machinable material	} Thin ◀◀ Web thickness ▶▶ Thick	{ Large cutting resistance High rigidity Poor chip raking performance High-hardness material, cross hole drilling, etc.
Small cutting resistance Low rigidity Good chip raking performance Machinable material	} Thin ◀◀ Web thickness ▶▶ Thick	{ Large cutting resistance High rigidity Poor chip raking performance High-hardness material, cross hole drilling, etc.		
Margin	<p>The tip determines the drill diameter and functions as a drill guide during drilling. The margin width is determined in consideration of friction with a drilled hole.</p> <p>Poor guiding performance Small ◀◀ Margin width ▶▶ Large Good guiding performance</p>			
Diameter Back Taper	<p>To reduce friction with the inside of the drilled hole, the portion of the flute from the tip to the shank is tapered slightly. The degree of taper is usually represented by the quantity of reduction in the diameter with respect to the flute length, which is approx. 0.04–0.1mm. It is set at a larger value for high-efficiency drills and the work material that allows drilled holes to be closed.</p>			

CUTTING EDGE SHAPES

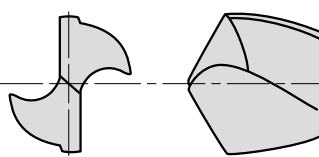
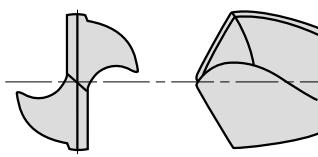
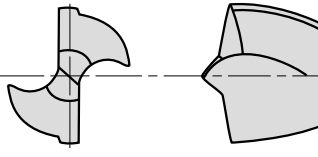



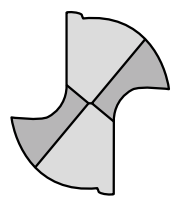
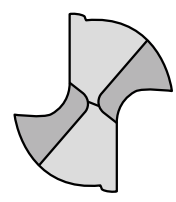
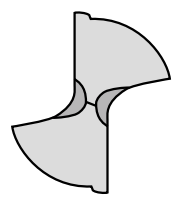
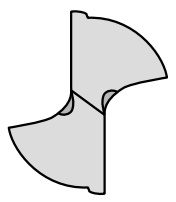

Shape			
	<Conical>	<Flat>	<Centre Point>
Features	<ul style="list-style-type: none"> ● The flank is conical and the clearance angle increases toward the centre of the drill. ● It is a general shape used commonly for soft and hard materials. 	<ul style="list-style-type: none"> ● The flank is flat to facilitate cutting and initial bite. ● This shape is frequently used for small-diameter drills. 	<ul style="list-style-type: none"> ● This shape has two-stage point angle for better centricity and reduction in burr generation. ● It is used for drills for thin sheet machining and steel frame machining.

WEB THINNING

The rake angle of the cutting edge of a drill reduces toward the centre, and it changes into a negative angle at the chisel edge. During drilling, the centre of a drill crushes the work, generating 50–70% of the cutting resistance. Web thinning is very effective for reduction in the cutting resistance of a drill, early removal of cut chips at the chisel edge, and better biting.













Shape				
	X type	XR type	S type	N type
Features	The thrust load substantially reduces, and the biting performance improves. This shape is effective when the web is rather thick.	The biting performance is slightly inferior to that of X type, but the cutting edge is hard and the applicable range of work is wide.	Cutting is easy. This shape is generally used.	Effective when the web is comparatively thick.
Major Applications	General drilling and deep hole drilling.	Long life. General drilling and stainless steel drilling.	General drilling for steel, cast iron, and non-ferrous metal.	Deep hole drilling.

DRILLING CHIPS

Types of Chips	Shape	Features and Ease of Raking
1. Conical Spiral		Fan-shaped chips cut by the cutting edge are curved by the flute. Chips of this type are produced when the feed rate of ductile material is small. If the chip breaks after several turns, the chip breaking performance is satisfactory.
2. Long Pitch		Long pitch chips exit without coiling and will easily coil around the drill.
3. Fan		This is a chip broken by the drill flute and the wall of a drilled hole. It is generated when the feed rate is high.
4. Segment		A conical spiral chip that is broken just before the chip grows into the long-pitch shape by the wall of the drilled hole due to its insufficient ductility. Excellent chip disposal and chip discharge.
5. Zigzag		A chip that is buckled and folded because of the shape of flute and the characteristics of the material. It easily causes chip packing at the flute.
6. Needle		Chips broken by vibration or broken when brittle material is curled with a small radius. The breaking performance is comparatively satisfactory, but these chips can become closely packed.

TOOL WEAR AND DAMAGE

CAUSES AND COUNTERMEASURES

Tool Damage Form		Cause	Countermeasure
Flank Wear		<ul style="list-style-type: none"> • Tool grade is too soft. • Cutting speed is too high. • Flank angle is too small. • Feed rate is extremely low. 	<ul style="list-style-type: none"> • Tool grade with high wear resistance. • Lower cutting speed. • Increase flank angle. • Increase feed rate.
Crater Wear		<ul style="list-style-type: none"> • Tool grade is too soft. • Cutting speed is too high. • Feed rate is too high. 	<ul style="list-style-type: none"> • Tool grade with high wear resistance. • Lower cutting speed. • Lower feed rate.
Chipping		<ul style="list-style-type: none"> • Tool grade is too hard. • Feed rate is too high. • Lack of cutting edge strength. • Lack of shank or holder rigidity. 	<ul style="list-style-type: none"> • Tool grade with high toughness. • Lower feed rate. • Increase honing. (Round honing is to be changed to chamfer honing.) • Use large shank size.
Fracture		<ul style="list-style-type: none"> • Tool grade is too hard. • Feed rate is too high. • Lack of cutting edge strength. • Lack of shank or holder rigidity. 	<ul style="list-style-type: none"> • Tool grade with high toughness. • Lower feed rate. • Increase honing. (Round honing is to be changed to chamfer honing.) • Use large shank size.
Plastic Deformation		<ul style="list-style-type: none"> • Tool grade is too soft. • Cutting speed is too high. • Depth of cut and feed rate are too large. • Cutting temperature is high. 	<ul style="list-style-type: none"> • Tool grade with high wear resistance. • Lower cutting speed. • Decrease depth of cut and feed rate. • Tool grade with high thermal conductivity.
Welding		<ul style="list-style-type: none"> • Cutting speed is low. • Poor sharpness. • Unsuitable grade. 	<ul style="list-style-type: none"> • Increase cutting speed. (For DIN Ck45, cutting speed 80m/min.) • Increase rake angle. • Tool grade with low affinity. (Coated grade, cermet grade)
Thermal Cracks		<ul style="list-style-type: none"> • Expansion or shrinkage due to cutting heat. • Tool grade is too hard. • *Especially in milling. 	<ul style="list-style-type: none"> • Dry cutting. (For wet cutting, flood workpiece with cutting fluid) • Tool grade with high toughness.
Notching		<ul style="list-style-type: none"> • Hard surfaces such as uncut surfaces, chilled parts and machining hardened layers. • Friction caused by jagged shape chips. (Caused by small vibration) 	<ul style="list-style-type: none"> • Tool grade with high wear resistance. • Increase rake angle to improve sharpness.
Flaking		<ul style="list-style-type: none"> • Cutting edge welding and adhesion. • Poor chip disposal. 	<ul style="list-style-type: none"> • Increase rake angle to improve sharpness. • Enlarge chip pocket.
Flank Wear Fracture		<ul style="list-style-type: none"> • Damage due to the lack of strength of a curved cutting edge. 	<ul style="list-style-type: none"> • Increase honing. • Tool grade with high toughness.
*Damage for polycrystallines			
Crater Wear Fracture		<ul style="list-style-type: none"> • Tool grade is too soft. • Cutting resistance is too high and causes high cutting heat. 	<ul style="list-style-type: none"> • Decrease honing. • Tool grade with high wear resistance.
*Damage for polycrystallines			

CUTTING TOOL MATERIALS

Cemented carbide (WC-Co) was developed in 1923 and was later improved by adding TiC and TaC. In 1969, CVD coating technology was developed, and coated carbide has since been used widely. TiC-TiN based cermet was developed in 1974. Today, "Coated Carbide grades for roughing and cermet for finishing" is a well established trend.

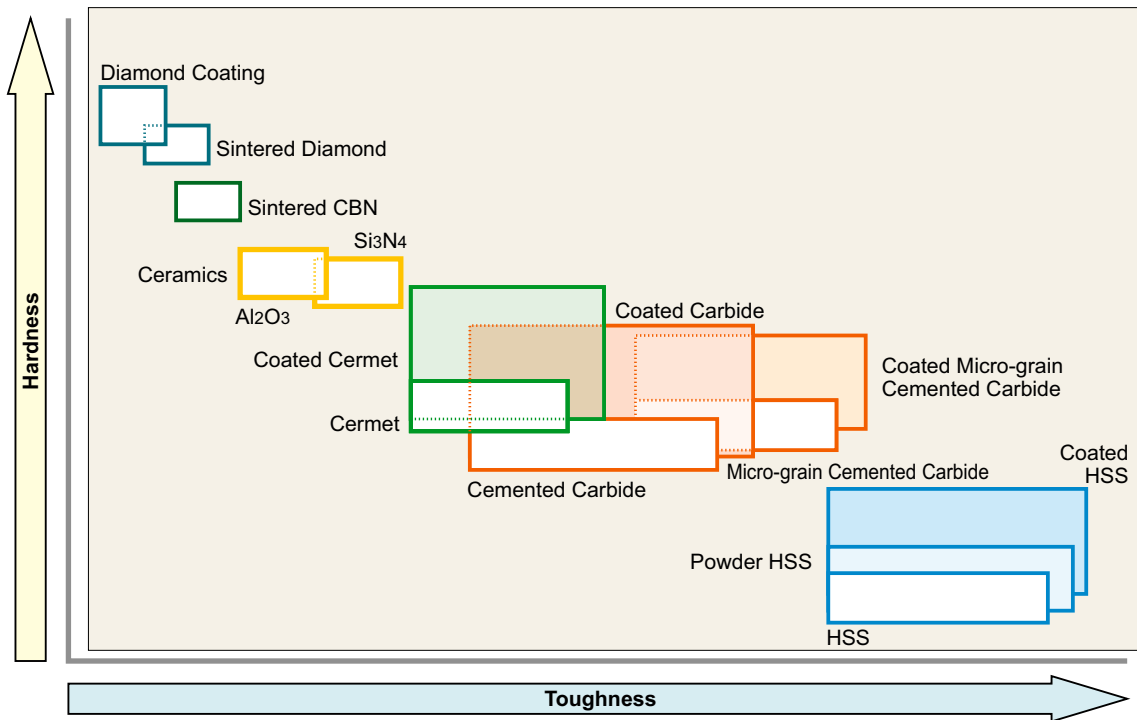

GRADE CHARACTERISTICS

Hard Materials	Hardness (HV)	Energy Formation (kcal/g-atom)	Solubility in Iron (%.1250°C)	Thermal Conductivity (W/m·k)	Thermal * Expansion (x 10 ⁻⁶ /k)	Tool Material
Diamond	>9,000	–	Highly Soluble	2,100	3.1	Sintered Diamond
CBN	>4,500	–	–	1,300	4.7	Sintered CBN
Si ₃ N ₄	1,600	–	–	100	3.4	Ceramics
Al ₂ O ₃	2,100	-100	≠0	29	7.8	Ceramics Cemented Carbide
TiC	3,200	-35	< 0.5	21	7.4	Cermet Coated Carbide
TiN	2,500	-50	–	29	9.4	Cermet Coated Carbide
TaC	1,800	-40	0.5	21	6.3	Cemented Carbide
WC	2,100	-10	7	121	5.2	Cemented Carbide

*1W/m·K=2.39×10⁻³cal/cm·sec·°C

GRADE CHAIN

For Cutting Tools

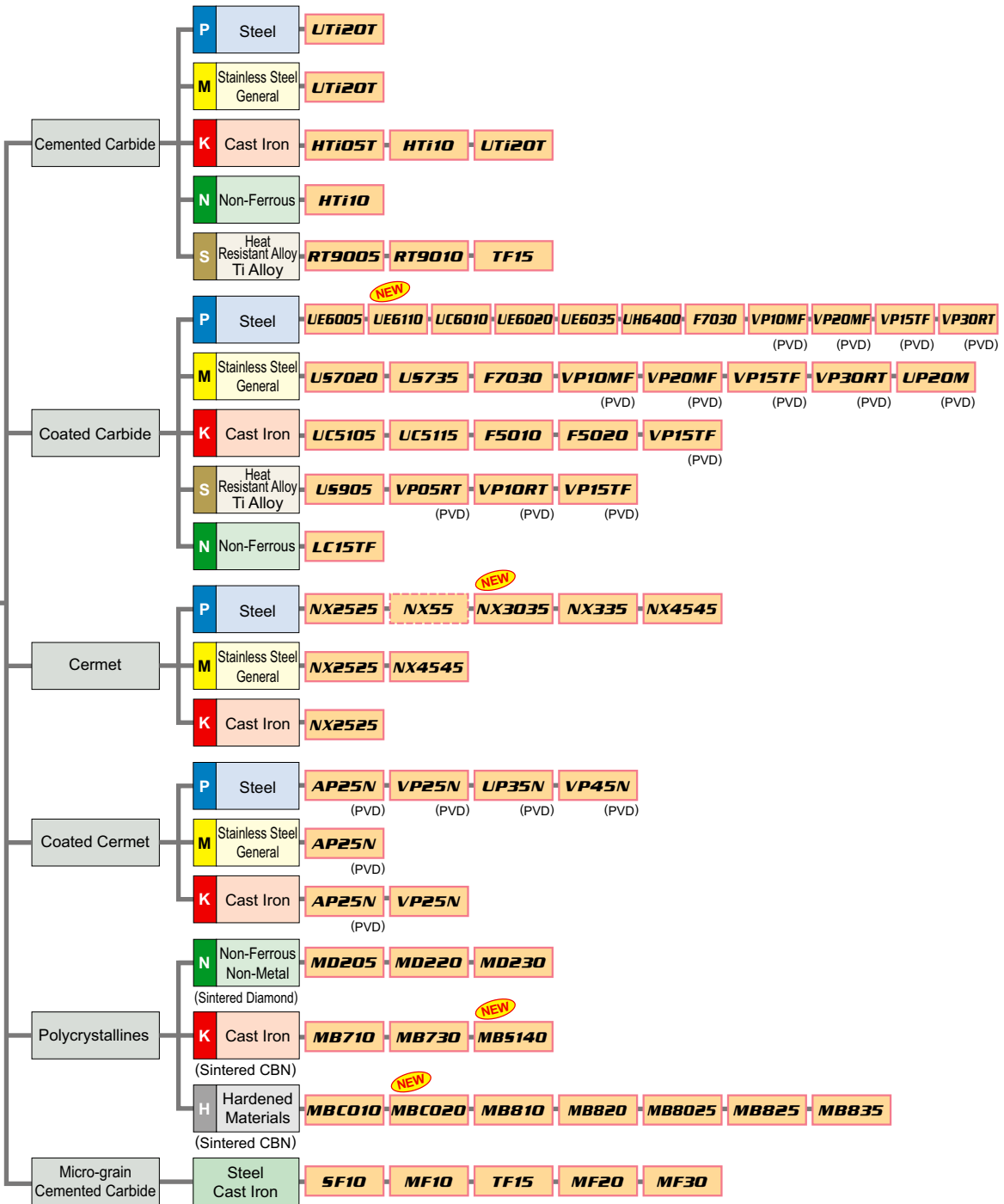

For Wear Resistance



For Construction Tools

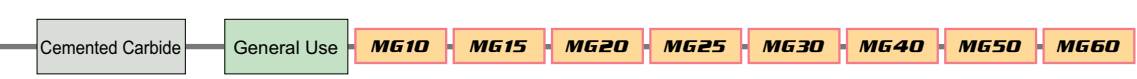

* Grade to be replaced by new products.

GRADES COMPARISON TABLE

CEMENTED CARBIDE

Classification	ISO	Mitsubishi Carbide	Sandvik	Kennametal	Seco Tools	Iscar	Sumitomo Electric	Tungaloy	Kyocera	Dijet	Hitachi Tool	
	Symbol											
Turning	P	P01										
		P10		S1P	P10		IC70	ST10P	TX10S		SRT	WS10
		P20	UTi20T	SMA	K125M TTM		IC70 IC50M	ST20E	TX20 TX25		SRT DX30	EX35
		P30	UTi20T	SM30	GK K600 TTR		IC50M IC54	A30 A30N	TX30 UX30	PW30	SR30 DX30	EX35 EX40
		P40		S6	G13		IC54	ST40E	TX40		SR30 DX35	EX45
	M	M10		H10A	K313	890		EH510 U10E	TU10		UMN	WA10B
		M20	UTi20T	H13A	K68 KMF K125M TTM	HX 883	IC08	EH520 U2	TU20 UX30		DX25 UMS	EX35
		M30	UTi20T	H10F SM30	K600 TTR		IC08 IC28	A30 A30N	UX30		DX25 UMS	EX40 EX45
		M40		S6	G13		IC128		TU40		UM40	EX45
	K	K01	HTi05T	H1P	K605			H1 H2	TH03 KS05F		KG03	WH05
		K10	HTi10	H1P H10 HM	K313 K110M THM THM-U	890	IC20	EH10 EH510	G1F TH10	KW10	KG10 KT9	WH10
		K20	UTi20T	H13A	K715 KMF K600	890 HX 883	IC20 IC10	G10E EH20 EH520	G2F, KS15F G2, KS20	GW10	CR1 KG20	WH20
		K30	UTi20T		THR	883	IC10 IC28	G10E	G3		KG30	
	N	N01		H10 H13A	K605			H1 H2	KS05F		KG03	
		N10	HTi10		K313 K110M THM THM-U	890 H15		EH10 EH510	TH10 H10T		KG10 KT9	
		N20			K715 KMF K600	HX KX 883 H15 H25		G10E EH20 EH520	KS15F		CR1 KG20	
		N30			G13 THR	H25					KG30	
	S	S01	RT9005								KG03	
		S10	RT9005 RT9010	H10 H10A H10F H13A	K10 K313 THM	890		EH10 EH510	KS05F TH10		FZ05 KG10	
		S20	RT9010 TF15		K715 KMF	890 883 HX H25		EH20 EH520	KS15F KS20		FZ15 KG20	
S30		TF15		G13 K600 THR						KG30		
Milling	P	P10		S1P						SRT		
		P20	UTi20T		K125		IC50M IC28	A30N	TX25		SRT DX30	EX35
		P30	UTi20T		GX K600		IC50M IC28	A30N	UX30	PW30	SR30 DX30	EX35 EX40
		P40					IC28			PW30	SR30	EX45
	M	M10			K110M						UMN	
		M20	UTi20T		K313			A30N			DX25 UMS	EX35
		M30	UTi20T		KFM K600		IC28	A30N	UX30		DX25 UMS	EX40 EX45
		M40					IC28		TU40			EX45
	K	K01	HTi05T								KG03	
		K10	HTi10	H1P	K110M K313		IC20	G10E	TH10	KW10	KG10	WH10
		K20	UTi20T		KFM	HX	IC20 IC10	G10E			KT9 CR1 KG20	WH20
		K30	UTi20T				IC10 IC28				KG30	

(Note) The above table is selected from a publication. We have not obtained approval from each company.

GRADES COMPARISON TABLE

MICRO GRAIN

Classification	ISO	Mitsubishi Carbide	Sandvik	Kennametal	Seco Tools	Sumitomo Electric	Tungaloy	Kyocera	Dijet	Hitachi Tool	
	Symbol										
Cutting Tools	Z	Z01	SF10 MF07 MF10	6UF 8UF PN90		F0	F MD08F		FZ05 FB10	NM08	
		Z10	HTi10 MF20	H6FF 12UF		890	XF1 F1 AFU	M MD10 MD05F MD07F	FW30	FZ10 FZ15 FB15	NM15
		Z20	TF15 UF30	N6F H10F		890 883	AF0 SF2 AF1	MD15 EM10 MD20		FZ15 FB15 FB20	BRM20 EF20N
		Z30				883	A1 CC	UM		FZ20 FB20	NM25

CERMET

Classification	ISO	Mitsubishi Carbide	Sandvik	Kennametal	Seco Tools	Iscar	Sumitomo Electric	Tungaloy	Kyocera	Dijet	Hitachi Tool	
	Symbol											
Turning	P	P01	AP25N			IC20N IC520N	T110A T2000Z	NS520 AT520 GT520 GT720	TN30 PV30	LN10 CX50		
		P10	AP25N NX2525	CT5015 GC1525	KT315 TTI25	CM CMP	IC20N IC520N IC530N	T1200A T2000Z	NS520 AT530 GT720 GT730	TN60 TN6020 PV60 PV7020	CX50 CX75	CZ25
		P20	AP25N UP35N NX2525 NX3035	GC1525	KT325		IC20N IC75T IC30N IC520N IC530N	T1200A T2000Z T3000Z	NS530 GT530 GT730 NS730	TN90 TN6020 PV90 PV7020	CX75	CH550
		P30	VP45N				IC75T IC30N	T3000Z	NS530 NS730			
	M	M10	NX2525 AP25N	GC1525	TTI25	CM CMP		T110A T2000Z	NS520 AT530 GT530 GT720	TN60 TN6020 PV60 PV7020	LN10 CX50	
		M20	NX2525 AP25N NX3035					T1200A T2000Z	NS530 GT730 NS730	TN90 TN6020 PV90 PV7020	CX50 CX75	CH550
		M30						T3000Z				
	K	K01	AP25N NX2525					T110A T2000Z	NS520 AT520 GT520 GT720	TN30 PV30	LN10	
		K10	AP25N NX2525	CT5015	KT325 TTI25			T1200A T2000Z	NS520 GT530 GT730 NS730	TN60 TN6020 PV60 PV7020	LN10	
		K20	AP25N NX2525					T3000Z			CX75	
	Milling	P	P10	NX2525		C15M	IC30N			TN60	CX75	
			P20	NX2525	CT530	KT530M HT7 KT605M	C15M	IC30N		NS530	TN100M	CX75 CX90
P30			NX4545				IC30N	T250A	NS530 NS540 NS740		CX90 CX99	MZ3000 CH7035
M		M10	NX2525				IC30N			TN60		
		M20	NX2525	CT530	KT530M HT7 KT605M	C15M	IC30N		NS530	TN100M	CX75	CH550 CH7030 MZ1000 MZ2000
		M30	NX4545					T250A	NS540 NS740		CX90 CX99	MZ3000 CH7035
K		K01										
		K10	NX2525						NS530	TN60		
		K20	NX2525		KT530M HT7						CX75	

(Note) The above table is selected from a publication. We have not obtained approval from each company.

CVD COATED GRADE

Classification	ISO	Mitsubishi Carbide	Sandvik	Kennametal	Seco Tools	Iscar	Sumitomo Electric	Tungaloy	Kyocera	Dijet	Hitachi Tool		
	Symbol												
Turning	P	P01	UE6005	GC4005	KC9105	TP1000 TK1000	IC9150	AC700G	T9005	CA5505	JC110V	HC5000	
		P10	UE6005 UE6110 UE6020 UC6010	GC4015 GC3115	KC9110 TN7005 TN7010	TP1000 TK1000 TP2000 TK2000	IC9150 IC9015	AC700G AC2000	T9005 T9015	CA5505 CA5515	JC110V JC215V	HG8010 GM8015 GM10	
		P20	UE6110 UE6020 UC6010	GC4015 GC4225 GC4025 GC2015 LC25	KC9125 KC9225 TN7015	TP2000 TK2000 TP200	IC9250 IC9025 IC9054	AC2000 AC3000	T9015 T9025	CA5515 CA5525 CA5025 CR9025	JC110V JC215V	HG8025 GM8020	
		P30	UE6035 UH6400 US735	GC4225 GC4025 GC4035 GC2025 GC2135	KC8050 TN7025	TP3000 TP300	IC9350 IC656	AC3000 AC630M	T9025 T9035	CA5525 CA5535 CR9025	JC215V JC325V	GM25	
		P40	UE6035 UH6400 US735	GC4035 GC235	KC9140 KC9040 KC9240 KX9245 TN7035 TPC35	TP3000 TP400 TP40	IC635	AC630M	T9035	CA5535	JC325V JC450V	GM8035 GX30	
	M	M10	US7020	GC2015	TN7010	TP200	IC9250	AC610M	T9015	CA6515 CA6015	JC110V	GM10	
		M20	US7020	GC2025	KC9225 TN7015	TP200	IC9250 IC9025 IC9054	AC610M AC630M	T6020 T9025	CA6525 CA6015	JC110V JC215V	GM8020	
		M30	US735	GC2135 GC235	KC8050 TN8025	TP300 TP400 TP40	IC9350 IC9025	AC630M AC3000	T6030		JC215V JC325V	HG8025 GM25	
		M40	US735		KC9240 KC9245 TPC35	TP400 TP40	IC656 IC635				JC325V JC450V	GX30	
	K	K01	UC5105	GC3205 GC3210		TK1000	IC9150 IC9007	AC300G	T5010	CA4010	JC105V	GM3005	
		K10	UC5115	GC3205 GC3210 GC3115	KC9315 KC9110 TN5015	TK1000 TK2000	IC9150 IC9015 IC4010 IC418 IC428	AC700G	T5010	CA4010 CA4115	JC110V	HG8010 GM8015	
		K20	UC5115	GC3215	KC9320 TN5020	TK2000 TP200	IC9015	AC700G	T5020	CA4120	JC110V JC215V	HG8025 GM8020	
		K30			KC9325	TP200					JC215V	GM25	
	Milling	P	P10			TN2510 TN25M		IC9080 IC4100	ACP100			JC730U	
			P20	FH7020 F7030	GC4020	TN7525	T200M T250M	IC520M	ACP100			JC730U	
			P30	F7030	GC4030	KC930M		T250M T350M T25M	IC4050	AC230	T3030		
P40				GC4240 GC4040	KC935M TN7535	T350M			AC230			GF30 GX2030 GX30	
M		M10				TN25M							
		M20	F7030			TN7525	T250M T25M	IC520M			JC730U		
		M30	F7030	GC2040	KC930M TN7535		T350M T25M	IC4050		T3030			
		M40										GF30 GX30	
K		K01						IC9080			JC600		
		K10	F5010			TN5505 TN5515		IC4100	ACK200 AC211	T1015	JC600		
		K20	F5020	GC3220 GC3020 K20D K20W	KC915M TN5520	T150M T200M	IC520M DT7150	ACK200	T1015		JC610		
		K30		GC3040	KC930M KC935M	T200M	IC4050				JC610		

(Note) The above table is selected from a publication. We have not obtained approval from each company.

GRADES COMPARISON TABLE

PVD COATED GRADE

Classification	ISO	Mitsubishi Carbide	Sandvik	Kennametal	Seco Tools	Iscar	Sumitomo Electric	Tungaloy	Kyocera	Dijet	Hitachi Tool		
	Symbol												
Turning	P	P01							PR915	JC5003			
		P10	VP10MF		KC5010 KC5510	CP200	IC507		AH710	PR915 PR930	JC5003		
		P20	VP15TF VP20MF	GC1020 GC1025	KC5025	CP250	IC908 IC928 IC1008 IC1028		AH710 AH330	PR630 PR915 PR930 PR660	JC5015		
		P30	VP15TF VP20MF	GC1025 GC4125	K7010 K7020 K7235	CP500	IC928 IC1008 IC1028		GH330 GH730 AH120 AH330 AH740	PR630 PR660	JC5015		
		P40		GC1020 GC2145	K7030	CP500	IC928 IC1008 IC1028		AH120	PR660			
	M	M01						EH510Z EH10Z		PR915			
		M10	VP10MF	GC1005 GC1025	KC5010 KC5510	CP200	IC507 IC907	EH510Z EH10Z		PR915 PR930	JC5003		
		M20	VP15TF VP20MF	GC1020 GC1025 GC4125	KC5025 KC730 KC5525	CP200 CP500	IC354 IC3028	EH520Z EH20Z	GH330 GH730	PR630 PR915 PR930	JC5015		
		M30	VP15TF VP20MF	GC1020 GC2035	KC5025 KC5525	CP500	IC908 IC928 IC1008 IC1028		AH120	PR630 PR660	JC5015		
		M40		GC2145			IC228 IC328			PR660			
	K	K01						EH10Z	AH110		JC5003		
		K10			KC5010 KC5510	CP200		EH10Z	GH110 AH110		JC5003 JC5015		
		K20	VP15TF	GC1020	KC7015	CP200 CP250	IC928 IC1008 IC908 IC22	EH20Z	AH120		JC5015		
		K30	VP15TF	GC4125	KC7225	CP500	IC928 IC1008 IC908 IC22						
		S	S01	VP05RT	GC1105					AH110	PR915	JC5003	
	S	S10	VP05RT VP10RT	GC1005 GC1025	KC5410 KC5010 KC5510	CP200 CP250 CP500		EH510Z EH10Z	AH120	PR915	JC5015		
		S20	VP10RT VP15TF	GC4125	KC5025 KC5525	CP250 CP500		EH20Z EH520Z		PR915			
		S30	VP15TF	GC2145									
		Milling	P	P01					ACP100			JC5003	PTH08M PCA08M PCS08M TB6005 JX1005
				P10			KC715M		IC903 IC950	ACZ310 ACP100		PR730 PR830	JC5003 JC5030
P20	VP15TF			GC1025	KC522M KC525M	F25M	IC950 IC900 IC908 IC910	ACZ310 ACZ330 ACP200		PR630 PR730 PR830 PR660	JC5015 JC5030 JC5040	TB6020 CY150 CY15 JX1015	
P30	VP15TF VP30RT			GC1030	KC725M	F25M F30M	IC900 IC928 IC300 IC328	ACZ330 ACZ350 ACZ200	GH330 AH330 AH120 AH740	PR630 PR660 PR730 PR830	JC5015 JC5040	TB6045 CY250 CY25 HC844 JX1045 PTH30E	
P40	VP30RT				KC735M	F40M T60M	IC900 IC928 IC300 IC328	ACZ350 ACP300	AH120	PR660	JC5040	PTH30E TB6060 PTH40H JX1060 GF30 GX30	
P50													
M	M01											PCS08M	
	M10			GC1025	KC715M					PR630 PR730 PR830	JC5003	CY9020 JX1020	
	M20		VP15TF VP20RT	GC2030	KC522M KC525M	F25M	IC900 IC903 IC908 IC928	ACZ310 EH20Z	GH330	PR630 PR730 PR830 PR660	JC5015 JC5030 JC5040 JC4015	TB6020 CY150 CY15 JX1015	
	M30		VP15TF VP20RT VP30RT	GC2030	KC725M KC735M	F30M F40M	IC928 IC328	ACZ330 EH20Z ACZ350	AH120	PR630 PR660 PR730 PR830	JC5015 JC5030 JC5040 JC4015	TB6045 CY250 CY25 HC844 JX1045	
	M40		VP30RT			F40M	IC928 IC328	ACZ350	AH140	PR660	JC5015	TB6060 PTH40H JX1060 GF30 GX30	
	M40		VP30RT			F40M	IC928 IC328	ACZ350	AH140	PR660	JC5015	TB6060 PTH40H JX1060 GF30 GX30	
K	K01								AH110	PR510 PR905	JC5003	PTH08M PCA08M PCS08M	
	K10				KC510M		IC900 IC910	ACZ310 ACK200	AH110 GH110	PR510 PR905	JC5003	CY9020 TB6005 CY100H CY10H	
	K20		VP15TF VP20RT		KC520M KC525M		IC910 IC950	ACZ310 ACK200	AH120	PR510 PR905	JC5015	TB6020 CY150 CY15 PTH13S JX1015	
	K30		VP15TF VP20RT		KC725M KC735M		IC908 IC950 IC928	ACZ330 ACK300			JC5015	TB6045 CY250 CY25 PTH40H PTH30E JX1045	
	S		S01								JC5003		
S	S10		VP15TF		KC510M		IC908		AH120	PR660	JC5015	PCS08M	
	S20		VP15TF	GC1025	KC522M KC525M		IC908			PR660		CY100H CY10H	
	S30		VP15TF	GC2030	KC725M	F40M	IC328 IC928			PR660			
	H	H01								JC5003			
H	H10	VP15TF		KC635M	F15M					JC5015	PTH08M PCA08M JX1005 TB6005		
	H20	VP15TF		KC635M	F15M								
	H30	VP15TF		KC530M	F30M								

(Note) The above table is selected from a publication. We have not obtained approval from each company.

CBN

	ISO		Mitsubishi Carbide	Sandvik	Seco Tools	Element Six	Sumitomo Electric	Tungaloy	Kyocera	Dijet
	Classification	Symbol								
Turning	H	H01	MBC010 MB810		CBN100		BNX10 BNC150	BX310 BXC30		
		H10	MBC020 MB8025 MB820	CB7015 CB7020	CBN200	DCC500	BNC80 BNX20	BX330 BXC50	KBN510	JBN300
		H20	MBC020 MB8025 MB825	CB7050	CBN150	DCN450	BN250 BNC200 BNX25	BX360	KBN525	JBN245
		H30	MBC020 MB835		CBN350		BNC300 BN350	BX380		
	S	S01	MB730				BN600 BN700	BX950		
		S10								
		S20								
		S30								
	K	K01	MB710				BN500	BX930		
		K10	MB710 MB730	CB7050	CBN200	DBC80	BN700	BX480 BX950	KBN65B	JBN795
		K20	MB730 MBS140		CBN300		BN700 BNS800	BXC90	KBN900	JBN330
		K30	MBS140				BNS800	BXC90		

PCD

	ISO		Mitsubishi Carbide	Sandvik	GE	Element Six	Sumitomo Electric	Tungaloy	Kyocera	Dijet
	Classification	Symbol								
Turning	N	N01	MD205		1700	CTH025	DA90	DX180	KPD025	JDA735
		N10	MD205 MD220	CD10	1500	CTB010	DA150	DX160	KPD010	JDA745
		N20	MD220 MD230		1300	CTB002	DA200	DX140 DX120	KPD002	JDA715 JDA10
		N30	MD230		1600		DA2200		KPD001	

(Note) The above table is selected from a publication. We have not obtained approval from each company.

INSERT CHIP BREAKER COMPARISON TABLE

NEGATIVE INSERT TYPE

ISO Classification	Cutting Mode	Mitsubishi Carbide	Sandvik	Kennametal	Seco Tools	Sumitomo Electric	Tungaloy	Kyocera	Dijet	Hitachi Tool
P	Finish	PK * FH FY	QF	UF, FF	FF1	FA FL	01 * TF ZF	DP * GP, VF XP, XP-T		FE
	Light	C SA SH	PF MF	LF, FN	MF2	SU LU SX	NS, 27 TS, AS	HQ, CQ	PF UR UA, UT	BE CE
	Light (Mild Steel)	SY					17	XQ, XS		
	Light (With Wiper)	SW	WP, WF	FW	W-MF2	LUW	AFW, ASW	WP, WQ		
	Medium	MV MA MH	PM QM SM	MG, MN	MF3 M3 M5	GU UG UX	NM, ZM TM DM, 37	CJ, GS PS, HS PT, CS	PG UB	AB AY AE
	Medium (With Wiper)	MW	WM	MW	W-M3	GUW				
	Semi Heavy	STD GH	PR	RN	MR7	MU, MX	TH	GT, HT	UD, GG	AR, RE
	Heavy	HL, HM HX HV	QR, PR HR	MR RM, RH	R4, R6 R7 RR9	MP HG, HP	57 65, TU	HX	UC	HX HE
M	Finish Light	FH, FS	MF	K, FP		SU	SS	GU		SE
	Medium	MS MA, ES	MM	P, MP		EX, UP	SA, SM S	SU, HU ST	SF SG	DE
	Heavy	GH HL, HM	MR MR	RP	M5, MR7 56, R6	MP				
K	Finish Light	Std.	KF	FN		UZ	CM	Std., C		Y
	Medium	Std.	KM	Std., UN		UX	33, Std.	ZS, GC		V
	Heavy	Flat Top	KR			Flat Top		Flat Top		
S	Finish Light	FJ *		FS, K *	MF1 *					
	Medium	MJ *	○NGP, 23 *	○NGP *	M1	SU *	SA			
	Heavy	GJ	SR	MS						

*Peripheral ground type insert.

(Note) Above charts are based on published data and not authorized by each manufacturer.

INSERT CHIP BREAKER COMPARISON TABLE

TECHNICAL DATA

7° POSITIVE INSERT TYPE

ISO Classification	Cutting Mode	Mitsubishi Carbide	Sandvik	Kennametal	Seco Tools	Sumitomo Electric	Tungaloy	Kyocera	Dijet	Hitachi Tool
P	Finish Light	FV SV	UF, PF	11, UF LF	FF1 F1	FP, LU SU, SK	* 01, PF PS	GP XP, VF		JQ
	Light (With Wiper)	SW	* WK, WF, WP	FW	W-F1	LUW				
	Medium	MV Std.	UM, PM	MF	F2	MU	23 PM, 24	HQ XQ, GK	FT	JE
	Medium (With Wiper)	MW	WM	MW						
M	Finish Light	SV	MF				SS *			
	Medium	Std.	MM							
K	Medium	Flat Top	KF, KM, KR			Flat Top *	Flat Top	Flat Top *	FT	
S	Finish Light	FJ *		LF * HP *		SC *				

*Peripheral ground type insert.

(Note) Above charts are based on published data and not authorized by each manufacturer.

11° POSITIVE INSERT TYPE

ISO Classification	Cutting Mode	Mitsubishi Carbide	Sandvik	Kennametal	Seco Tools	Sumitomo Electric	Tungaloy	Kyocera	Dijet	Hitachi Tool
P	Finish Light	SV	PF	UF, LF		FK, LU, SU	* 01, PF, PS	GP, XP		JQ
	Medium	MV	PM	MF		MU	PM 23, 24	HQ, XQ		JE
M	Finish Light	SV	MF				SS *			
	Medium	MV	MM							

*Peripheral ground type insert.

(Note) Above charts are based on published data and not authorized by each manufacturer.

MATERIAL CROSS REFERENCE LIST

STRUCTURAL AND CONSTRUCTIONAL STEEL

Country										
Germany	U. K.		Sweden	USA	France	Belgium	Italy	Spain	Japan	
Standard										
W.-nr.	DIN	BS	EN	SS	AIS/SAE	AFNOR	NBN	UNI	UNF	JIS
1.0401	C15	080M15	–	1350	1015	CC12	–	C15C16	F.111	–
1.0402	C22	050A20	2C	1450	1020	CC20	C25-1	C20C21	F.112	–
1.0501	C35	060A35	–	1550	1035	CC35	C35-1	C35	F.113	–
1.0503	C45	080M46	–	1650	1045	CC45	C45-1	C45	F.114	–
1.0535	C55	070M55	–	1655	1055	–	C55-1	C55	–	–
1.0601	C60	080A62	43D	–	1060	CC55	C60-1	C60	–	–
1.0715	9SMn28	230M07	–	1912	1213	S250	–	CF9SMn28	11SMn28	SUM22
1.0718	9SMnPb28	–	–	1914	12L13	S250Pb	–	CF9SMnPb28	11SMnPb28	SUM22L
1.0722	10SPb20	–	–	–	–	10PbF2	–	CF10PB20	10SPb20	–
1.0726	35S20	212M36	8M	1957	1140	35MF4	–	–	F.210.G	–
1.0736	9SMn36	240M07	1B	–	1215	S300	–	CF9SMn36	12SMN35	–
1.0737	9SMnPb36	–	–	1926	12L14	S300Pb	–	CF9SMnPb36	12SMnP35	–
1.0904	55Si7	250A53	45	2085	9255	55S7	55Si7	55Si8	56Si7	–
1.0961	60SiCr7	–	–	–	9262	60SC7	60SiCr8	60SiCr8	60SiCr8	–
1.1141	Ck15	080M15	32C	1370	1015	XC12	C16-2	C16	C15K	S15C
1.1157	40Mn4	150M36	15	–	1039	35M5	–	–	–	–
1.1158	Ck25	–	–	–	1025	–	C25-2	–	–	S25C
1.1167	36Mn5	–	–	2120	1335	40M5	–	–	36Mn5	SMn438(H)
1.1170	28Mn6	150M28	14A	–	1330	20M5	28Mn6	C28Mn	–	SCMn1
1.1183	Cf35	060A35	–	1572	1035	XC38TS	C36	C36	–	S35C
1.1191	Ck45	080M46	–	1672	1045	XC42	C45-2	C45	C45K	S45C
1.1203	Ck55	070M55	–	–	1055	XC55	C55-2	C50	C55K	S55C
1.1213	Cf53	060A52	–	1674	1050	XC48TS	C53	C53	–	S50C
1.1221	Ck60	080A62	43D	1678	1060	XC60	C60-2	C60	–	S58C
1.1274	Ck101	060A96	–	1870	1095	–	–	–	–	SUP4
1.3401	G-X120Mn12	Z120M12	–	–	–	Z120M12	–	XG120Mn12	X120MN12	SCMnH/1
1.3505	100Cr6	534A99	31	2258	52100	100C6	–	100Cr6	F.131	SUJ2
1.5415	15Mo3	1501-240	–	2912	ASTM A204Gr.A	15D3	16Mo3	16Mo3KW	16Mo3	–
1.5423	16Mo5	1503-245-420	–	–	4520	–	16Mo5	16Mo5	16Mo5	–
1.5622	14Ni6	–	–	–	ASTM A350LF5	16N6	18Ni6	14Ni6	15Ni6	–
1.5662	X8Ni9	1501-509;510	–	–	ASTM A353	–	10Ni36	X10Ni9	XBNI09	–
1.5680	12Ni19	–	–	–	2515	Z18N5	12Ni20	–	–	–
1.5710	36NiCr6	640A35	111A	–	3135	35NC6	–	–	–	SNC236
1.5732	14NiCr10	–	–	–	3415	14NC11	–	16NiCr11	15NiCr11	SNC415(H)
1.5752	14NiCr14	655M13; 655A12	36A	–	3415;3310	12NC15	13NiCr12	–	–	SNC815(H)
1.6511	36CrNiMo4	816M40	110	–	9840	40NCD3	–	38NiCrMo4(KB)	35NiCrMo4	–
1.6523	21NiCrMo2	805M20	362	2506	8620	20NCD2	–	20NiCrMo2	20NiCrMo2	SNCM220(H)
1.6546	40NiCrMo22	311-Type 7	–	–	8740	–	40NiCrMo2	40NiCrMo2(KB)	40NiCrMo2	SNCM240
1.6582	34CrNiMo6	817M40	24	2541	4340	35NCD6	35CrNiMo6	35NiCrMo6(KB)	–	–
1.6587	17CrNiMo6	820A16	–	–	–	18NCD6	17CrNiMo7	–	14NiCrMo13	–
1.6657	14NiCrMo134	832M13	36C	–	–	–	14NiCrMo13	15NiCrMo13	14NiCrMo131	–
1.7015	15Cr3	523M15	–	–	5015	12C3	15Cr2	–	–	SCr415(H)
1.7033	34Cr4	530A32	18B	–	5132	32C4	34Cr4	34Cr4(KB)	35Cr4	SCr430(H)
1.7035	41Cr4	530M40	18	–	5140	42C4	41Cr4	41Cr4	42Cr4	SCr440(H)
1.7045	42Cr4	–	–	2245	5140	–	–	–	42Cr4	SCr440
1.7131	16MnCr5	(527M20)	–	2511	5115	16MC5	16MnCr5	16MnCr5	16MnCr5	–
1.7176	55Cr3	527A60	48	–	5155	55C3	55Cr3	–	–	SUP9(A)
1.7218	25CrMo4	1717CDS110	–	2225	4130	25CD4	25CrMo4	25CrMo4(KB)	55Cr3 AM26CrMo4	SCM420;SCM430

MATERIAL CROSS REFERENCE LIST

TECHNICAL DATA

Country										
Germany	U. K.			Sweden	USA	France	Belgium	Italy	Spain	Japan
Standard										
W.-nr.	DIN	BS	EN	SS	AIS/SAE	AFNOR	NBN	UNI	UNF	JIS
1.7220	34CrMo4	708A37	19B	2234	4137;4135	35CD4	34CrMo4	35CrMo4	34CrMo4	SCM432;SCCRM3
1.7223	41CrMo4	708M40	19A	2244	4140;4142	42CD4TS	41CrMo4	41CrMo4	42CrMo4	SCM 440
1.7225	42CrMo4	708M40	19A	2244	4140	42CD4	42CrMo4	42CrMo4	42CrMo4	SCM440(H)
1.7262	15CrMo5	–	–	2216	–	12CD4	–	–	12CrMo4	SCM415(H)
1.7335	13CrMo4 4	1501-620Gr27	–	–	ASTM A182 F11;F12	15CD3.5 15CD4.5	14CrMo45	14CrMo45	14CrMo45	–
1.7361	32CrMo12	722M24	40B	2240	–	30CD12	32CrMo12	32CrMo12	F.124.A	–
1.7380	10CrMo9 10	1501-622	–	2218	ASTM A182	12CD9,10	–	12CrMo9,10	TU.H	–
		Gr31;45	–	–	F.22	–	–	–	–	–
1.7715	14MoV6 3	1503-660-440	–	–	–	–	13MoCrV6	–	13MoCrV6	–
1.8159	50CrV4	735A50	47	2230	6150	50CV4	50CrV4	50CrV4	51CrV4	SUP10
1.8509	41CrAlMo7	905M39	41B	2940	–	40CAD6,12	41CrAlMo7	41CrAlMo7	41CrAlMo7	–
1.8523	39CrMoV13 9	897M39	40C	–	–	–	39CrMoV13	36CrMoV12	–	–

TOOL STEELS

Country										
Germany	U. K.			Sweden	USA	France	Belgium	Italy	Spain	Japan
Standard										
W.-nr.	DIN	BS	EN	SS	AIS/SAE	AFNOR	NBN	UNI	UNF	JIS
1.1545	C105W1	–	–	1880	W.110	Y ₁ 105	–	C98KU C100KU	F.515 F.516	–
1.663	C125W	–	–	–	W.112	Y ₂ 120	–	C120KU	(C120)	SK2
1.2067	100Cr6	BL3	–	–	L3	Y100C6	–	–	100Cr6	–
1.2080	X210Cr12	BD3	–	–	D3	Z200C12	–	X210Cr13KU X250Cr12KU	X210Cr12	SKD1
1.2344	X40CrMoV5 1	BH13	–	2242	H13	Z40CDV5	–	X35CrMoV05KU X40CrMoV511KU	X40CrMoV5	SKD61
1.2363	X100CrMoV5 1	BA2	–	2260	A2	Z100CDV5	–	X100CrMoV51KU	X100CrMoV5	SKD12
1.2419	105WCr6	–	–	2140	–	105WC13	–	100WCr6 107WCr5KU	105WCr5	SKS31 SKS2;SKS3
1.2436	X210CrW12	–	–	2312	–	–	–	X215CrW12 1KU	X210CrW12	SKD2
1.2542	45WCrV7	BS1	–	2710	S1	–	–	45WCrV8KU	45WCrSi8	–
1.2581	X30WCrV9 3 X30WCrV9 3KU	BH21	–	–	H21	Z30WCV9	–	X28W09KU X30WCrV9 3KU	X30WCrV9	SKD5
1.2601	X165CrMoV12	–	–	2310	–	–	–	X165CrMoV12KU	X160CrMoV12	–
1.2713	55NiCrMoV6	–	–	–	L6	55NCDV7	–	–	F.520.S	SKT4
1.2833	100V1	BW2	–	–	W210	Y ₁ 105V	C98KU 102V2KU	–	–	SKS43
1.3243	S 6-5-2-5	–	–	2723	–	Z85WDKCV 06-05-05-04-02	–	HS 6-5-2-5	HS 6-5-2-5	SKH55
1.3255	S 18-1-2-5	BT4	–	–	T4	Z80WKCV 18-05-04-01	–	X78WCo1805KU	HS 18-1-1-5	SKH3
1.3343	S 6-5-2	BM2	–	2722	M2	Z85WDCV 06-05-04-02	–	X82WMo0605KU	HS 6-5-2	SKH9
1.3348	S 2-9-2	–	–	2782	M7	Z100WCWV 09-04-02-02	–	HS 2-9-2	HS 2-9-2	–
1.3355	S 18-0-1	BT1	–	–	T1	Z80WCV 18-04-01	–	X75W18KU	HS18-0-1	SKH2

MATERIAL CROSS REFERENCE LIST

STAINLESS AND HEAT RESISTANT MATERIALS

Country										
Germany		U. K.		Sweden	USA	France	Belgium	Italy	Spain	Japan
Standard										
W.-nr.	DIN	BS	EN	SS	AIS/SAE	AFNOR	NBN	UNI	UNF	JIS
1.4000	X7Cr13	403S17	-	2301	403	Z6C13	-	X6Cr13	F.3110	SUS403
1.4001	X7Cr14								F.8401	
1.4006	X10Cr13	410S21	56A	2302	410	Z10C14	-	X12Cr13	F.3401	SUS410
1.4016	X8Cr17	430S15	60	2320	430	Z8C17	-	X8Cr17	F.3113	SUS430
1.4027	G-X20Cr14	420C29	56B	-	-	Z20C13M	-	-	-	SCS2
1.4034	X46Cr13	420S45	56D	2304	-	Z40CM Z38C13M	-	X40Cr14	F.3405	SUS420J2
1.4057	X22CrNi17	431S29	57	2321	431	Z15CNI6.02	-	X16CrNi6	F.3427	SUS431
1.4104	X12CrMoS17	-	-	2383	430F	Z10CF17	-	X10CrS17	F.3117	SUS430F
1.4113	X6CrMo17	434S17	-	2325	434	Z8CD17.01	-	X8CrMo17	-	SUS434
1.4301	X5CrNi189	304S15	58E	2332	304	Z6CN18.09	-	X5CrNi18 10	F.3551 F.3541 F.3504	SUS304
1.4305	X12CrNiS18 8	303S21	58M	2346	303	Z10CNF 18.09	-	X10CrNiS 18 09	F.3508	SUS303
1.4306	X2CrNi18 9	304S12 304C12	-	2352 2333	304L	Z2CN18.10 Z3CN19.10	-	X2CrNi18 11	F.3503	SCS19 SUS304L
1.4308	G-X6CrNi18 9	304C15	-	-	-	Z6CN18.10M	-	-	-	SCS13
1.4310	X12CrNi17 7	-	-	2331	301	Z12CN17.07	-	X12CrNi17 07	F.3517	SUS301
1.4311	X2CrNiN 18 10	304S62	-	2371	304LN	Z2CN18.10	-	-	-	SUS304LN
1.4313	X5CrNi13 4	425C11	-	-	-	Z4CND13.4M	-	-	-	SCS5
1.4401	X5CrNiMo 18 10	316S16	58J	2347	316	Z6CND17.11	-	X5CrNiMo17 12	F.3543	SUS316
1.4408	G-X6CrNiMo 18 10	316C16	-	-	-	-	-	-	F.8414	SCS14
1.4429	X2CrNiMoN 18 13	-	-	2375	316LN	Z2CND17.13	-	-	-	SUS316LN
1.4435	X2CrNiMo 18 12	316S12	-	2353	316L	Z2CND17.13 -	-	X2CrNiMo17 13 -	-	SCS16 SUS316L
1.4438	X2CrNiMo 18 16	317S12	-	2367	317L	Z2CND19.15	-	X2CrNiMo18 16	-	SUS317L
1.4460	X8CrNiMo 27 5	-	-	2324	329	- -	- -	- -	- -	SUS329JL SCH11;SCS11
1.4541	X10CrNiTi 18 9	2337	321S12	58B	321	Z6CNT18.10	-	X6CrNiTi18 11	F.3553 F.3523	SUS321
1.4550	X10CrNiNb 18 9	347S17	58F	2338	347	Z6CNNb18.10	-	X6CrNiNb18 11	F.3552 F.3524	SUS347
1.4571	X10CrNiMoTi 18 10	320S17	58J	2350	316Ti	Z6CNDT17.12	-	X6CrNiMoTi 17 12	F.3535	-
1.4581	G-X5CrNi MoNb 18 10	318C17	-	-	-	Z4CNDNb 18 12M	-	XG8CrNiMo 18 11	-	SCS22
1.4583	X10CrNi MoNb 18 12	-	-	-	318	Z6CNDNb 17 13B	-	X6CrNiMoNb 17 13	-	-
1.4718	X45CrSi 93	401S45	52	-	HW3	Z45CS 9	-	X45CrSi8	F.322	SUH1
1.4724	X10CrA113	403S17	-	-	405	Z10C13	-	X10CrA112	F.311	SUS405
1.4742	X10CrA118	430S15	60	-	430	Z10CAS18	-	X8Cr17	F.3113	SUS430
1.4747	X80CrNiSi20	443S65	59	-	HNV6	Z80CSN20.02	-	X80CrSiNi20	F.320B	SUH4
1.4762	X10CrA124	-	-	2322	446	Z10CAS24	-	X16Cr26	-	SUH446
1.4828	X15CrNiSi 20 12	309S24	-	-	309	Z15CNS20.12	-	-	-	SUH309
1.4845	X12CrNi25 21	310S24	-	2361	310S	Z12CN25 20	-	X6CrNi25 20	F.331	SUH310
1.4864	X12NiCrSi 36 16	-	-	-	330	Z12NCS35.16	-	-	-	SUH330
1.4865	G-X40NiCrSi 38 18	330C11	-	-	-	-	-	XG50NiCr 39 19	-	SCH15
1.4871	X53CrMnNiN 21 9	349S54	-	-	EV8	Z52CMN21.09	-	X53CrMnNiN219	-	SUH35;SUH36
1.4878	X12CrNiTi 18 9	321S12 321S20	58B, 58C	-	321	Z6CNT18.12B	-	X6CrNiTi18 11	F.3523	SU321

MATERIAL CROSS REFERENCE LIST

TECHNICAL DATA

GREY CAST IRON (unalloyed)

Country										
Germany		U. K.		Sweden	USA	France	Belgium	Italy	Spain	Japan
Standard										
W.-Nr.	DIN	BS	EN	SS	AIS/SAE	AFNOR	NBN	UNI	UNF	JIS
–	–	–	–	–	ASTM	–	–	–	–	–
–	–	–	–	–	A48-76	–	–	–	–	–
–	–	–	–	01 00	–	–	–	–	–	–
–	GG 10	–	–	01 10	No 20 B	Ft 10 D	–	–	–	FC100
0.6015	GG 15	Grade 150	–	01 15	No 25 B	Ft 15 D	–	G15	FG15	FC150
0.6020	GG 20	Grade 220	–	01 20	No 30 B	Ft 20 D	–	G20	–	FC200
0.6025	GG 25	Grade 260	–	01 25	No 35 B	Ft 25 D	–	G25	FG25	FC250
–	–	–	–	–	No 40 B	–	–	–	–	–
0.6030	GG 30	Grade 300	–	01 30	No 45 B	Ft 30 D	–	G30	FG30	FC300
0.6035	GG 35	Grade 350	–	01 35	No 50 B	Ft 35 D	–	G35	FG35	FC350
0.6040	GG 40	Grade 400	–	01 40	No 55 B	Ft 40 D	–	–	–	–

GREY CAST IRON (alloyed)

Country										
Germany		U. K.		Sweden	USA	France	Belgium	Italy	Spain	Japan
Standard										
W.-Nr.	DIN	BS	EN	SS	AIS/SAE	AFNOR	NBN	UNI	UNF	JIS
–	DIN4694	3468: 1974	–	MB	ASTM	–	–	–	–	–
–	GGL-	–	–	ISO-215	A436-72	A32-301	–	–	–	–
–	NiCr 20 2	L-NiCr 20 2	–	05 23	Type 2	L-NC 20 2	–	–	–	–

NODULAR CAST IRON (unalloyed)

Country										
Germany		U. K.		Sweden	USA	France	Belgium	Italy	Spain	Japan
Standard										
W.-Nr.	DIN	BS	EN	SS	AIS/SAE	AFNOR	NBN	UNI	UNF	JIS
–	–	2789; 1973	–	–	A536-72	NF A32-201	–	–	–	–
0.7040	GGG 40	SNG 420/12	–	07 17-02	60-40-18	FCS 400-12	–	GS 370-17	FGE 38-17	FCD400
–	GGG 40.3	SNG 370/17	–	07 17-12	–	FGS 370-17	–	–	–	–
0.7033	GGG 35.3	–	–	07 17-15	–	–	–	–	–	–
0.7050	GGG 50	SNG 500/7	–	07 27-02	80-55-06	FGS 500-7	–	GS 500	FGE 50-7	FCD500
–	GGG 60	SNG 600/3	–	07 32-03	–	FGS 600-3	–	–	–	FCD600
0.7070	GGG 70	SNG 700/2	–	07 37-01	100-70-03	FGS 700-2	–	GS 700-2	FGS 70-2	FCD700

ALLOYED CAST IRON

Country										
Germany		U. K.		Sweden	USA	France	Belgium	Italy	Spain	Japan
Standard										
W.-Nr.	DIN	BS	EN	SS	AIS/SAE	AFNOR	NBN	UNI	UNF	JIS
–	DIN 1694	–	–	–	–	–	–	–	–	–
–	GGGNiMn 13 7	L-NiMn 13 7	–	07 72	–	L-MN 13 7	–	–	–	–
–	GGG NiCr 20 2	L-NiMn 20 2	–	07 76	Type 2	L-NC 20 2	–	–	–	–

MALLEABLE CAST IRON

Country										
Germany		U. K.		Sweden	USA	France	Belgium	Italy	Spain	Japan
Standard										
W.-Nr.	DIN	BS	EN	SS	AIS/SAE	AFNOR	NBN	UNI	UNF	JIS
–	–	–	–	–	ASTM	–	–	–	–	–
–	–	–	–	–	A47-74	–	–	–	–	–
–	–	–	–	–	A 220-76 2)	–	–	–	–	–
–	–	8 290/6	–	08 14	–	MN 32-8	–	–	–	–
–	GTS-35	B 340/12	–	08 15	32510	MN 35-10	–	–	–	FCMW330
0.8145	GTS-45	P 440/7	–	08 52	40010	MN 450	–	GMN45	–	FCMW370
0.8155	GTS-55	P 510/4	–	08 54	50005	MP 50-5	–	GMN55	–	FCMP490
–	GTS-65	P 570/3	–	08 58	70003	MP 60-3	–	–	–	FCMP540
–	GTS-70	P 690/2	–	08 62	A 220-80002	MN700-2	–	–	–	FCMP690

SURFACE ROUGHNESS

SURFACE ROUGHNESS

(From JIS B 0601-1994)

Type	Code	Determination	Determination Example (Figure)
Arithmetical Mean Roughness	Ra	<p>Ra means the value obtained by the following formula and expressed in micrometer (μm) when sampling only the reference length from the roughness curve in the direction of the mean line, taking X-axis in the direction of mean line and Y-axis in the direction of longitudinal magnification of this sampled part and the roughness curve is expressed by $y=f(x)$:</p> $Ra = \frac{1}{\ell} \int_0^{\ell} f(x) dx$	
Maximum Height	Rz	<p>Rz shall be that only when the reference length is sampled from the roughness curve in the direction of the mean line, the distance between the top profile peak line and the bottom profile valley line on this sampled portion is measured in the longitudinal magnification direction of roughness curve and the obtained value is expressed in micrometer (μm). (Note) When finding Rz, a portion without an exceptionally high peak or low valley, which may be regarded as a flaw, is selected as the sampling length. $Rz = R_p + R_v$</p>	
Ten-Point Mean Roughness	RzJIS	<p>RzJIS shall be that only when the reference length is sampled from the roughness curve in the direction of its mean line, the sum of the average value of absolute values of heights of five highest profile peaks (Y_p) and the depths of five deepest profile valleys (Y_v) measured in the vertical magnification direction from the mean line of this sampled portion and this sum is expressed in micrometer (μm).</p> $Rz_{JIS} = \frac{(Y_{p1} + Y_{p2} + Y_{p3} + Y_{p4} + Y_{p5}) + (Y_{v1} + Y_{v2} + Y_{v3} + Y_{v4} + Y_{v5})}{5}$	<p>$Y_{p1}, Y_{p2}, Y_{p3}, Y_{p4}, Y_{p5}$: altitudes of the five highest profile peaks of the sampled portion corresponding to the reference length l. $Y_{v1}, Y_{v2}, Y_{v3}, Y_{v4}, Y_{v5}$: altitudes of the five deepest profile valleys of the sampled portion corresponding to the reference length l.</p>

RELATIONSHIP BETWEEN ARITHMETICAL MEAN (Ra) AND CONVENTIONAL DESIGNATION (REFERENCE DATA)

Arithmetical Mean Roughness Ra		Max. Height Rz	Ten-Point Mean Roughness RzJIS	Sampling Length for Rz · RzJIS l (mm)	Conventional Finish Mark
Standard Series	Cutoff Value λ_c (mm)	Standard Series			
0.012 a	0.08	0.05s	0.05z	0.08	▽▽▽▽
0.025 a		0.1 s	0.1 z		
0.05 a	0.25	0.2 s	0.2 z	0.25	
0.1 a		0.4 s	0.4 z		
0.2 a		0.8 s	0.8 z		
0.4 a	0.8	1.6 s	1.6 z	0.8	▽▽▽
0.8 a		3.2 s	3.2 z		
1.6 a		2.5	6.3 s		6.3 z
3.2 a	12.5 s		12.5 z		
6.3 a	8	25 s	25 z	8	▽
12.5 a		50 s	50 z		
25 a		100 s	100 z		
50 a	-	200 s	200 z	-	-
100 a		400 s	400 z		

*The correlation among the three is shown for convenience and is not exact.

*Ra: The evaluation length of Rz and RzJIS is the cutoff value and sampling length multiplied by 5, respectively.

HARDNESS COMPARISON TABLE

HARDNESS CONVERSION NUMBERS OF STEEL

Brinell Hardness (HB), 10mm Ball, Load: 3,000kgf		Vickers Hardness (HV)	Rockwell Hardness (3)				Shore Hardness (HS)	Tensile Strength (Approx.)		Brinell Hardness (HB), 10mm Ball, Load: 3,000kgf		Vickers Hardness (HV)	Rockwell Hardness (3)				Shore Hardness (HS)	Tensile Strength (Approx.)	
Standard Ball	Tungsten Carbide Ball		A Scale, Load: 60kgf, Diamond Point (HRA)	B Scale, Load: 100kgf, 1/16" Ball (HRB)	C Scale, Load: 150kgf, Diamond Point (HRC)	D Scale, Load: 100kgf, Diamond Point (HRD)		MPa (2)	MPa (2)	Standard Ball	Tungsten Carbide Ball		A Scale, Load: 60kgf, Diamond Point (HRA)	B Scale, Load: 100kgf, 1/16" Ball (HRB)	C Scale, Load: 150kgf, Diamond Point (HRC)	D Scale, Load: 100kgf, Diamond Point (HRD)		MPa (2)	MPa (2)
—	—	940	85.6	—	68.0	76.9	97	—	429	429	455	73.4	—	45.7	59.7	61	1510		
—	—	920	85.3	—	67.5	76.5	96	—	415	415	440	72.8	—	44.5	58.8	59	1460		
—	—	900	85.0	—	67.0	76.1	95	—	401	401	425	72.0	—	43.1	57.8	58	1390		
—	(767)	880	84.7	—	66.4	75.7	93	—	388	388	410	71.4	—	41.8	56.8	56	1330		
—	(757)	860	84.4	—	65.9	75.3	92	—	375	375	396	70.6	—	40.4	55.7	54	1270		
—	(745)	840	84.1	—	65.3	74.8	91	—	363	363	383	70.0	—	39.1	54.6	52	1220		
—	(733)	820	83.8	—	64.7	74.3	90	—	352	352	372	69.3	(110.0)	37.9	53.8	51	1180		
—	(722)	800	83.4	—	64.0	73.8	88	—	341	341	360	68.7	(109.0)	36.6	52.8	50	1130		
—	(712)	—	—	—	—	—	—	—	331	331	350	68.1	(108.5)	35.5	51.9	48	1095		
—	(710)	780	83.0	—	63.3	73.3	87	—	321	321	339	67.5	(108.0)	34.3	51.0	47	1060		
—	(698)	760	82.6	—	62.5	72.6	86	—	—	—	—	—	—	—	—	—	—		
—	(684)	740	82.2	—	61.8	72.1	—	—	311	311	328	66.9	(107.5)	33.1	50.0	46	1025		
—	(682)	737	82.2	—	61.7	72.0	84	—	302	302	319	66.3	(107.0)	32.1	49.3	45	1005		
—	(670)	720	81.8	—	61.0	71.5	83	—	293	293	309	65.7	(106.0)	30.9	48.3	43	970		
—	(656)	700	81.3	—	60.1	70.8	—	—	285	285	301	65.3	(105.5)	29.9	47.6	—	950		
—	(653)	697	81.2	—	60.0	70.7	81	—	277	277	292	64.6	(104.5)	28.8	46.7	41	925		
—	(647)	690	81.1	—	59.7	70.5	—	—	269	269	284	64.1	(104.0)	27.6	45.9	40	895		
—	(638)	680	80.8	—	59.2	70.1	80	—	262	262	276	63.6	(103.0)	26.6	45.0	39	875		
—	630	670	80.6	—	58.8	69.8	—	—	255	255	269	63.0	(102.0)	25.4	44.2	38	850		
—	627	667	80.5	—	58.7	69.7	79	—	248	248	261	62.5	(101.0)	24.2	43.2	37	825		
—	—	677	80.7	—	59.1	70.0	—	—	241	241	253	61.8	100	22.8	42.0	36	800		
—	601	640	79.8	—	57.3	68.7	77	—	235	235	247	61.4	99.0	21.7	41.4	35	785		
—	—	640	79.8	—	57.3	68.7	—	—	229	229	241	60.8	98.2	20.5	40.5	34	765		
—	578	615	79.1	—	56.0	67.7	75	—	223	223	234	—	97.3	(18.8)	—	—	—		
—	—	607	78.8	—	55.6	67.4	—	—	217	217	228	—	96.4	(17.5)	—	33	725		
—	555	591	78.4	—	54.7	66.7	73	2055	212	212	222	—	95.5	(16.0)	—	—	705		
—	—	533	77.1	—	52.5	65.0	—	1915	207	207	218	—	94.6	(15.2)	—	32	690		
—	514	547	76.9	—	52.1	64.7	70	1890	201	201	212	—	93.8	(13.8)	—	31	675		
(495)	—	539	76.7	—	51.6	64.3	—	1855	197	197	207	—	92.8	(12.7)	—	30	655		
—	—	530	76.4	—	51.1	63.9	—	1825	192	192	202	—	91.9	(11.5)	—	29	640		
—	495	528	76.3	—	51.0	63.8	68	1820	187	187	196	—	90.7	(10.0)	—	—	620		
(477)	—	516	75.9	—	50.3	63.2	—	1780	183	183	192	—	90.0	(9.0)	—	28	615		
—	—	508	75.6	—	49.6	62.7	—	1740	179	179	188	—	89.0	(8.0)	—	27	600		
—	477	508	75.6	—	49.6	62.7	66	1740	174	174	182	—	87.8	(6.4)	—	—	585		
(461)	—	495	75.1	—	48.8	61.9	—	1680	170	170	178	—	86.8	(5.4)	—	26	570		
—	—	491	74.9	—	48.5	61.7	—	1670	167	167	175	—	86.0	(4.4)	—	—	560		
—	461	491	74.9	—	48.5	61.7	65	1670	163	163	171	—	85.0	(3.3)	—	25	545		
444	—	474	74.3	—	47.2	61.0	—	1595	156	156	163	—	82.9	(0.9)	—	—	525		
—	—	472	74.2	—	47.1	60.8	—	1585	149	149	156	—	80.8	—	—	23	505		
—	444	472	74.2	—	47.1	60.8	63	1585	143	143	150	—	78.7	—	—	22	490		
—	—	—	—	—	—	—	—	—	137	137	143	—	76.4	—	—	21	460		
—	—	—	—	—	—	—	—	—	131	131	137	—	74.0	—	—	—	450		
—	—	—	—	—	—	—	—	—	126	126	132	—	72.0	—	—	20	435		
—	—	—	—	—	—	—	—	—	121	121	127	—	69.8	—	—	19	415		
—	—	—	—	—	—	—	—	—	116	116	122	—	67.6	—	—	18	400		
—	—	—	—	—	—	—	—	—	111	111	117	—	65.7	—	—	15	385		

(Note 1) The above list is the same as that of AMS Metals Hand book with tensile strength in approximate metric value and Brinell hardness over a recommended range.

(Note 2) 1MPa=1N/mm²

(Note 3) Figures in () are rarely used and are included for reference. This list has been taken from JIS Handbook Steel I.

FIT TOLERANCE TABLE(HOLE)

Classification of Standard Dimensions (mm)		Class of Geometrical Tolerance Zone of Holes															
>	≤	B10	C9	C10	D8	D9	D10	E7	E8	E9	F6	F7	F8	G6	G7	H6	H7
—	3	+180	+85	+100	+34	+45	+60	+24	+28	+39	+12	+16	+20	+8	+12	+6	+10
		+140	+60	+60	+20	+20	+20	+14	+14	+14	+6	+6	+6	+2	+2	0	0
3	6	+188	+100	+118	+48	+60	+78	+32	+38	+50	+18	+22	+28	+12	+16	+8	+12
		+140	+70	+70	+30	+30	+30	+20	+20	+20	+10	+10	+10	+4	+4	0	0
6	10	+208	+116	+138	+62	+76	+98	+40	+47	+61	+22	+28	+35	+14	+20	+9	+15
		+150	+80	+80	+40	+40	+40	+25	+25	+25	+13	+13	+13	+5	+5	0	0
10	14	+220	+138	+165	+77	+93	+120	+50	+59	+75	+27	+34	+43	+17	+24	+11	+18
		+150	+95	+95	+50	+50	+50	+32	+32	+32	+16	+16	+16	+6	+6	0	0
14	18	+220	+138	+165	+77	+93	+120	+50	+59	+75	+27	+34	+43	+17	+24	+11	+18
		+150	+95	+95	+50	+50	+50	+32	+32	+32	+16	+16	+16	+6	+6	0	0
18	24	+244	+162	+194	+98	+117	+149	+61	+73	+92	+33	+41	+53	+20	+28	+13	+21
		+160	+110	+110	+65	+65	+65	+40	+40	+40	+20	+20	+20	+7	+7	0	0
24	30	+244	+162	+194	+98	+117	+149	+61	+73	+92	+33	+41	+53	+20	+28	+13	+21
		+160	+110	+110	+65	+65	+65	+40	+40	+40	+20	+20	+20	+7	+7	0	0
30	40	+270	+182	+220	+119	+142	+180	+75	+89	+112	+41	+50	+64	+25	+34	+16	+25
		+170	+120	+120													
40	50	+280	+192	+230	+119	+142	+180	+75	+89	+112	+41	+50	+64	+25	+34	+16	+25
		+180	+130	+130													
50	65	+310	+214	+260	+146	+174	+220	+90	+106	+134	+49	+60	+76	+29	+40	+19	+30
		+190	+140	+140													
65	80	+320	+224	+270	+146	+174	+220	+90	+106	+134	+49	+60	+76	+29	+40	+19	+30
		+200	+150	+150													
80	100	+360	+257	+310	+174	+207	+260	+107	+126	+159	+58	+71	+90	+34	+47	+22	+35
		+220	+170	+170													
100	120	+380	+267	+320	+174	+207	+260	+107	+126	+159	+58	+71	+90	+34	+47	+22	+35
		+240	+180	+180													
120	140	+420	+300	+360	+208	+245	+305	+125	+148	+185	+68	+83	+106	+39	+54	+25	+40
		+260	+200	+200													
140	160	+440	+310	+370	+208	+245	+305	+125	+148	+185	+68	+83	+106	+39	+54	+25	+40
		+280	+210	+210													
160	180	+470	+330	+390	+208	+245	+305	+125	+148	+185	+68	+83	+106	+39	+54	+25	+40
		+310	+230	+230													
180	200	+525	+355	+425	+242	+285	+355	+146	+172	+215	+79	+96	+122	+44	+61	+29	+46
		+340	+240	+240													
200	225	+565	+375	+445	+242	+285	+355	+146	+172	+215	+79	+96	+122	+44	+61	+29	+46
		+380	+260	+260													
225	250	+605	+395	+465	+242	+285	+355	+146	+172	+215	+79	+96	+122	+44	+61	+29	+46
		+420	+280	+280													
250	280	+690	+430	+510	+271	+320	+400	+162	+191	+240	+88	+108	+137	+49	+69	+32	+52
		+480	+300	+300													
280	315	+750	+460	+540	+271	+320	+400	+162	+191	+240	+88	+108	+137	+49	+69	+32	+52
		+540	+330	+330													
315	355	+830	+500	+590	+299	+350	+440	+182	+214	+265	+98	+119	+151	+54	+75	+36	+57
		+600	+360	+360													
355	400	+910	+540	+630	+299	+350	+440	+182	+214	+265	+98	+119	+151	+54	+75	+36	+57
		+680	+400	+400													
400	450	+1010	+595	+690	+327	+385	+480	+198	+232	+290	+108	+131	+165	+60	+83	+40	+63
		+760	+440	+440													
450	500	+1090	+635	+730	+327	+385	+480	+198	+232	+290	+108	+131	+165	+60	+83	+40	+63
		+840	+480	+480													

(Note) Values shown in the upper portion of the respective boxes are the upper dimensional tolerance, while values shown in the lower portion are the lower dimensional tolerance.

Class of Geometrical Tolerance Zone of Holes

H8	H9	H10	JS6	JS7	K6	K7	M6	M7	N6	N7	P6	P7	R7	S7	T7	U7	X7
+14 0	+25 0	+40 0	± 3	± 5	0 -6	0 -10	-2 -8	-2 -12	-4 -10	-4 -14	-6 -12	-6 -16	-10 -20	-14 -24	-	-18 -28	-20 -30
+18 0	+30 0	+48 0	± 4	± 6	+2 -6	+3 -9	-1 -9	0 -12	-5 -13	-4 -16	-9 -17	-8 -20	-11 -23	-15 -27	-	-19 -31	-24 -36
+22 0	+36 0	+58 0	± 4.5	± 7	+2 -7	+5 -10	-3 -12	0 -15	-7 -16	-4 -19	-12 -21	-9 -24	-13 -28	-17 -32	-	-22 -37	-28 -43
+27 0	+43 0	+70 0	± 5.5	± 9	+2 -9	+6 -12	-4 -15	0 -18	-9 -20	-5 -23	-15 -26	-11 -29	-16 -34	-21 -39	-	-26 -44	-33 -51 -38 -56
+33 0	+52 0	+84 0	± 6.5	± 10	+2 -11	+6 -15	-4 -17	0 -21	-11 -24	-7 -28	-18 -31	-14 -35	-20 -41	-27 -48	-	-33 -54	-46 -67 -56 -77
+39 0	+62 0	+100 0	± 8	± 12	+3 -13	+7 -18	-4 -20	0 -25	-12 -28	-8 -33	-21 -37	-17 -42	-25 -50	-34 -59	-	-39 -64 -45 -70	-51 -76 -61 -86
+46 0	+74 0	+120 0	± 9.5	± 15	+4 -15	+9 -21	-5 -24	0 -30	-14 -33	-9 -39	-26 -45	-21 -51	-30 -60 -32 -62	-42 -72 -48 -78	-55 -85 -64 -94	-76 -106 -91 -121	-
+54 0	+87 0	+140 0	± 11	± 17	+4 -18	+10 -25	-6 -28	0 -35	-16 -38	-10 -45	-30 -52	-24 -59	-38 -73 -41 -76	-58 -93 -66 -101	-78 -113 -91 -126	-111 -146 -131 -166	-
+63 0	+100 0	+160 0	± 12.5	± 20	+4 -21	+12 -28	-8 -33	0 -40	-20 -45	-12 -52	-36 -61	-28 -68	-48 -88 -50 -90 -53 -93	-77 -117 -85 -125 -93 -133	-107 -147 -119 -159 -131 -171	-	-
+72 0	+115 0	+185 0	± 14.5	± 23	+5 -24	+13 -33	-8 -37	0 -46	-22 -51	-14 -60	-41 -70	-33 -79	-60 -105 -106 -63 -109 -67 -113	-113 -159 -123 -169	-	-	-
+81 0	+130 0	+210 0	± 16	± 26	+5 -27	+16 -36	-9 -41	0 -52	-25 -57	-14 -66	-47 -79	-36 -88	-74 -126 -78 -130	-	-	-	-
+89 0	+140 0	+230 0	± 18	± 28	+7 -29	+17 -40	-10 -46	0 -57	-26 -62	-16 -73	-51 -87	-41 -98	-87 -144 -93 -150	-	-	-	-
+97 0	+155 0	+250 0	± 20	± 31	+8 -32	+18 -45	-10 -50	0 -63	-27 -67	-17 -80	-55 -95	-45 -108	-103 -166 -109 -172	-	-	-	-

FIT TOLERANCE TABLE(SHAFT)

Classification of Standard Dimensions (mm)		Class of Geometrical Tolerance Zone of Shafts														
>	≤	b9	c9	d8	d9	e7	e8	e9	f6	f7	f8	g5	g6	h5	h6	h7
-	3	-140	-60	-20	-20	-14	-14	-14	-6	-6	-6	-2	-2	0	0	0
		-165	-85	-34	-45	-24	-28	-39	-12	-16	-20	-6	-8	-4	-6	-10
3	6	-140	-70	-30	-30	-20	-20	-20	-10	-10	-10	-4	-4	0	0	0
		-170	-100	-48	-60	-32	-38	-50	-18	-22	-28	-9	-12	-5	-8	-12
6	10	-150	-80	-40	-40	-25	-25	-25	-13	-13	-13	-5	-5	0	0	0
		-186	-116	-62	-76	-40	-47	-61	-22	-28	-35	-11	-14	-6	-9	-15
10	14	-150	-95	-50	-50	-32	-32	-32	-16	-16	-16	-6	-6	0	0	0
		-193	-138	-77	-93	-50	-59	-75	-27	-34	-43	-14	-17	-8	-11	-18
14	18	-150	-95	-50	-50	-32	-32	-32	-16	-16	-16	-6	-6	0	0	0
		-193	-138	-77	-93	-50	-59	-75	-27	-34	-43	-14	-17	-8	-11	-18
18	24	-160	-110	-65	-65	-40	-40	-40	-20	-20	-20	-7	-7	0	0	0
		-212	-162	-98	-117	-61	-73	-92	-33	-41	-53	-16	-20	-9	-13	-21
24	30	-160	-110	-65	-65	-40	-40	-40	-20	-20	-20	-7	-7	0	0	0
		-212	-162	-98	-117	-61	-73	-92	-33	-41	-53	-16	-20	-9	-13	-21
30	40	-170	-120	-80	-80	-50	-50	-50	-25	-25	-25	-9	-9	0	0	0
		-232	-182	-119	-142	-75	-89	-112	-41	-50	-64	-20	-25	-11	-16	-25
40	50	-180	-130	-119	-142	-75	-89	-112	-41	-50	-64	-20	-25	-11	-16	-25
		-242	-192	-119	-142	-75	-89	-112	-41	-50	-64	-20	-25	-11	-16	-25
50	65	-190	-140	-100	-100	-60	-60	-60	-30	-30	-30	-10	-10	0	0	0
		-264	-214	-146	-174	-90	-106	-134	-49	-60	-76	-23	-29	-13	-19	-30
65	80	-200	-150	-146	-174	-90	-106	-134	-49	-60	-76	-23	-29	-13	-19	-30
		-274	-224	-146	-174	-90	-106	-134	-49	-60	-76	-23	-29	-13	-19	-30
80	100	-220	-170	-120	-120	-72	-72	-72	-36	-36	-36	-12	-12	0	0	0
		-307	-257	-174	-207	-107	-126	-159	-58	-71	-90	-27	-34	-15	-22	-35
100	120	-240	-180	-174	-207	-107	-126	-159	-58	-71	-90	-27	-34	-15	-22	-35
		-327	-267	-174	-207	-107	-126	-159	-58	-71	-90	-27	-34	-15	-22	-35
120	140	-260	-200	-145	-145	-85	-85	-85	-43	-43	-43	-14	-14	0	0	0
		-360	-300	-208	-245	-125	-148	-185	-68	-83	-106	-32	-39	-18	-25	-40
140	160	-280	-210	-145	-145	-85	-85	-85	-43	-43	-43	-14	-14	0	0	0
		-380	-310	-208	-245	-125	-148	-185	-68	-83	-106	-32	-39	-18	-25	-40
160	180	-310	-230	-145	-145	-85	-85	-85	-43	-43	-43	-14	-14	0	0	0
		-410	-330	-208	-245	-125	-148	-185	-68	-83	-106	-32	-39	-18	-25	-40
180	200	-340	-240	-170	-170	-100	-100	-100	-50	-50	-50	-15	-15	0	0	0
		-455	-355	-242	-285	-146	-172	-215	-79	-96	-122	-35	-44	-20	-29	-46
200	225	-380	-260	-170	-170	-100	-100	-100	-50	-50	-50	-15	-15	0	0	0
		-495	-375	-242	-285	-146	-172	-215	-79	-96	-122	-35	-44	-20	-29	-46
225	250	-420	-280	-170	-170	-100	-100	-100	-50	-50	-50	-15	-15	0	0	0
		-535	-395	-242	-285	-146	-172	-215	-79	-96	-122	-35	-44	-20	-29	-46
250	280	-480	-300	-190	-190	-110	-110	-110	-56	-56	-56	-17	-17	0	0	0
		-610	-430	-271	-320	-162	-191	-240	-88	-108	-137	-40	-49	-23	-32	-52
280	315	-540	-330	-271	-320	-162	-191	-240	-88	-108	-137	-40	-49	-23	-32	-52
		-670	-460	-271	-320	-162	-191	-240	-88	-108	-137	-40	-49	-23	-32	-52
315	355	-600	-360	-210	-210	-125	-125	-125	-62	-62	-62	-18	-18	0	0	0
		-740	-500	-299	-350	-182	-214	-265	-98	-119	-151	-43	-54	-25	-36	-57
355	400	-680	-400	-299	-350	-182	-214	-265	-98	-119	-151	-43	-54	-25	-36	-57
		-820	-540	-299	-350	-182	-214	-265	-98	-119	-151	-43	-54	-25	-36	-57
400	450	-760	-440	-230	-230	-135	-135	-135	-68	-68	-68	-20	-20	0	0	0
		-915	-595	-327	-385	-198	-232	-290	-108	-131	-165	-47	-60	-27	-40	-63
450	500	-840	-480	-327	-385	-198	-232	-290	-108	-131	-165	-47	-60	-27	-40	-63
		-995	-635	-327	-385	-198	-232	-290	-108	-131	-165	-47	-60	-27	-40	-63

(Note) Values shown in the upper portion of the respective boxes are the upper dimensional tolerance, while values shown in the lower portion are the lower dimensional tolerance.

Class of Geometrical Tolerance Zone of Shafts

h8	h9	js5	js6	js7	k5	k6	m5	m6	n6	p6	r6	s6	t6	u6	x6
0 -14	0 -25	± 2	± 3	± 5	+4 0	+6 0	+6 +2	+8 +2	+10 +4	+12 +6	+16 +10	+20 +14	—	+24 +18	+26 +20
0 -18	0 -30	± 2.5	± 4	± 6	+6 +1	+9 +1	+9 +4	+12 +4	+16 +8	+20 +12	+23 +15	+27 +19	—	+31 +23	+36 +28
0 -22	0 -36	± 3	± 4.5	± 7	+7 +1	+10 +1	+12 +6	+15 +6	+19 +10	+24 +15	+28 +19	+32 +23	—	+37 +28	+43 +34
0 -27	0 -43	± 4	± 5.5	± 9	+9 +1	+12 +1	+15 +7	+18 +7	+23 +12	+29 +18	+34 +23	+39 +28	—	+44 +33	+51 +40 +56 +45
0 -33	0 -52	± 4.5	± 6.5	± 10	+11 +2	+15 +2	+17 +8	+21 +8	+28 +15	+35 +22	+41 +28	+48 +35	—	+54 +41	+67 +54 +77 +64
0 -39	0 -62	± 5.5	± 8	± 12	+13 +2	+18 +2	+20 +9	+25 +9	+33 +17	+42 +26	+50 +34	+59 +43	+64 +48 +70 +54	+76 +60 +86 +70	—
0 -46	0 -74	± 6.5	± 9.5	± 15	+15 +2	+21 +2	+24 +11	+30 +11	+39 +20	+51 +32	+60 +41 +62 +43	+72 +53 +78 +59	+85 +66 +94 +75	+106 +87 +121 +102	—
0 -54	0 -87	± 7.5	± 11	± 17	+18 +3	+25 +3	+28 +13	+35 +13	+45 +23	+59 +37	+73 +51 +76 +54	+93 +71 +101 +79	+113 +91 +126 +104	+146 +124 +166 +144	—
0 -63	0 -100	± 9	± 12.5	± 20	+21 +3	+28 +3	+33 +15	+40 +15	+52 +27	+68 +43	+88 +63 +90 +65 +93 +68	+117 +92 +125 +100 +133 +108	+147 +122 +159 +134 +171 +146	—	—
0 -72	0 -115	± 10	± 14.5	± 23	+24 +4	+33 +4	+37 +17	+46 +17	+60 +31	+79 +50	+106 +77 +109 +80 +113 +84	+151 +122 +159 +130 +169 +140	—	—	—
0 -81	0 -130	± 11.5	± 16	± 26	+27 +4	+36 +4	+43 +20	+52 +20	+66 +34	+88 +56	+126 +94 +130 +98	—	—	—	—
0 -89	0 -140	± 12.5	± 18	± 28	+29 +4	+40 +4	+46 +21	+57 +21	+73 +37	+98 +62	+144 +108 +150 +114	—	—	—	—
0 -97	0 -155	± 13.5	± 20	± 31	+32 +5	+45 +5	+50 +23	+63 +23	+80 +40	+108 +68	+166 +126 +172 +132	—	—	—	—

TAPER STANDARD

Fig.1
Bolt Grip Taper

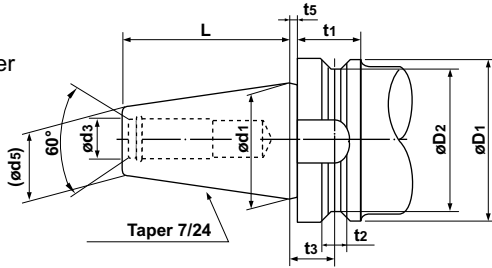
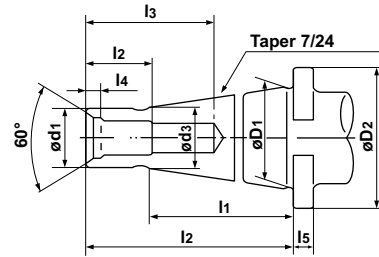

Fig.2
National Taper



● **Table 1**

Bearing Number	D1	D2	t1	t2	t3	t5	d1	d3	L	g	d5
BT35	53	43	20	10	13.0	2	38.1	13	56.5	M12×1.75	21.62
BT40	63	53	25	10	16.6	2	44.45	17	65.4	M16×2	25.3
BT45	85	73	30	12	21.2	3	57.15	21	82.8	M20×2.5	33.1
BT50	100	85	35	15	23.2	3	69.85	25	101.8	M24×3	40.1
BT60	155	135	45	20	28.2	3	107.95	31	161.8	M30×3.5	60.7

● **Table 2**

NT Number	D1	d1	l	l1	g		l2	l3	d3	l4	D2	l5
					Metric Screw	Wit•Screw						
30	31.75	17.4	70	50	M12	W 1/2	24	50	16.5	6	50	8
40	44.45	25.3	95	67	M16	W 5/8	30	70	24	7	63	10
50	69.85	39.6	130	105	M24	W 1	45	90	38	11	100	13
60	107.95	60.2	210	165	M30	W1 1/4	56	110	58	12	170	15

Fig.3
Morse Taper
(Shank with Tongue)

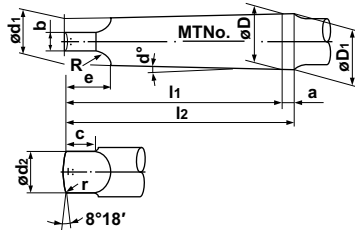
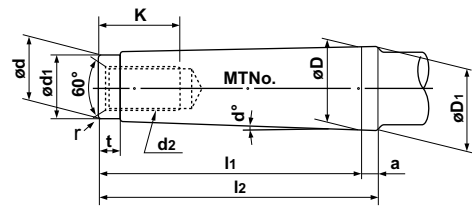

Fig.4
Morse Taper
(Shank with Screw)



● **Table 3** Shank with Tongue

Morse Taper Number	D	a	D1	d1	d2	l1	l2	b	c	e	R	r
0	9.045	3	9.201	6.104	6	56.5	59.5	3.9	6.5	10.5	4	1
1	12.065	3.5	12.240	8.972	8.7	62.0	65.5	5.2	8.5	13.5	5	1.2
2	17.780	5	18.030	14.034	13.5	75.0	80.0	6.3	10	16	6	1.6
3	23.825	5	24.076	19.107	18.5	94.0	99	7.9	13	20	7	2
4	31.267	6.5	31.605	25.164	24.5	117.5	124	11.9	16	24	8	2.5
5	44.399	6.5	44.741	36.531	35.7	149.5	156	15.9	19	29	10	3
6	63.348	8	63.765	52.399	51.0	210.0	218	19	27	40	13	4
7	83.058	10	83.578	68.185	66.8	286.0	296	28.6	35	54	19	5

● **Table 4** Shank with Screw

Morse Taper Number	D	a	D1	d	d1	l1	l2	t	r	d2	K
0	9.045	3	9.201	6.442	6	50	53	4	0.2	—	—
1	12.065	3.5	12.240	9.396	9	53.5	57	5	0.2	M6	16
2	17.780	5	18.030	14.583	14	64	69	5	0.2	M10	24
3	23.825	5	24.076	19.759	19	81	86	7	0.6	M12	28
4	31.267	6.5	31.605	25.943	25	102.5	109	9	1.0	M16	32
5	44.399	6.5	44.741	37.584	35.7	129.5	136	9	2.5	M20	40
6	63.348	8	63.765	53.859	51	182	190	12	4.0	M24	50
7	83.058	10	83.578	70.052	65	250	260	18.5	5.0	M33	80

DRILL DIAMETERS FOR TAPPING

● Metric Coarse Screw Thread

Nominal	Drill Diameter	
	HSS	Carbide
M1 ×0.25	0.75	0.75
M1.1×0.25	0.85	0.85
M1.2×0.25	0.95	0.95
M1.4×0.3	1.10	1.10
M1.6×0.35	1.25	1.30
M1.7×0.35	1.35	1.40
M1.8×0.35	1.45	1.50
M2 ×0.4	1.60	1.65
M2.2×0.45	1.75	1.80
M2.3×0.4	1.90	1.95
M2.5×0.45	2.10	2.15
M2.6×0.45	2.15	2.20
M3 ×0.5	2.50	2.55
M3.5×0.6	2.90	2.95
M4 ×0.7	3.3	3.4
M4.5×0.75	3.8	3.9
M5 ×0.8	4.2	4.3
M6 ×1.0	5.0	5.1
M7 ×1.0	6.0	6.1
M8 ×1.25	6.8	6.9
M9 ×1.25	7.8	7.9
M10 ×1.5	8.5	8.7
M11 ×1.5	9.5	9.7
M12 ×1.75	10.3	10.5
M14 ×2.0	12.0	12.2
M16 ×2.0	14.0	14.2
M18 ×2.5	15.5	15.7
M20 ×2.5	17.5	17.7
M22 ×2.5	19.5	19.7
M24 ×3.0	21.0	—
M27 ×3.0	24.0	—
M30 ×3.5	26.5	—
M33 ×3.5	29.5	—
M36 ×4.0	32.0	—
M39 ×4.0	35.0	—
M42 ×4.5	37.5	—
M45 ×4.5	40.5	—
M48 ×5.0	43.0	—

● Metric Fine Screw Thread

Nominal	Drill Diameter	
	HSS	Carbide
M1 ×0.2	0.80	0.80
M1.1×0.2	0.90	0.90
M1.2×0.2	1.00	1.00
M1.4×0.2	1.20	1.20
M1.6×0.2	1.40	1.40
M1.8×0.2	1.60	1.60
M2 ×0.25	1.75	1.75
M2.2×0.25	1.95	2.00
M2.5×0.35	2.20	2.20
M3 ×0.35	2.70	2.70
M3.5×0.35	3.20	3.20
M4 ×0.5	3.50	3.55
M4.5×0.5	4.00	4.05
M5 ×0.5	4.50	4.55
M5.5×0.5	5.00	5.05
M6 ×0.75	5.30	5.35
M7 ×0.75	6.30	6.35
M8 ×1.0	7.00	7.10
M8 ×0.75	7.30	7.35
M9 ×1.0	8.00	8.10
M9 ×0.75	8.30	8.35
M10 ×1.25	8.80	8.90
M10 ×1.0	9.00	9.10
M10 ×0.75	9.30	9.35
M11 ×1.0	10.0	10.1
M11 ×0.75	10.3	10.3
M12 ×1.5	10.5	10.7
M12 ×1.25	10.8	10.9
M12 ×1.0	11.0	11.1
M14 ×1.5	12.5	12.7
M14 ×1.0	13.0	13.1
M15 ×1.5	13.5	13.7
M15 ×1.0	14.0	14.1
M16 ×1.5	14.5	14.7
M16 ×1.0	15.0	15.1
M17 ×1.5	15.5	15.7
M17 ×1.0	16.0	16.1
M18 ×2.0	16.0	16.3
M18 ×1.5	16.5	16.7
M18 ×1.0	17.0	17.1

Nominal	Drill Diameter	
	HSS	Carbide
M20 ×2.0	18.0	18.3
M20 ×1.5	18.5	18.7
M20 ×1.0	19.0	19.1
M22 ×2.0	20.0	—
M22 ×1.5	20.5	—
M22 ×1.0	21.0	—
M24 ×2.0	22.0	—
M24 ×1.5	22.5	—
M24 ×1.0	23.0	—
M25 ×2.0	23.0	—
M25 ×1.5	23.5	—
M25 ×1.0	24.0	—
M26 ×1.5	24.5	—
M27 ×2.0	25.0	—
M27 ×1.5	25.5	—
M27 ×1.0	26.0	—
M28 ×2.0	26.0	—
M28 ×1.5	26.5	—
M28 ×1.0	27.0	—
M30 ×3.0	27.0	—
M30 ×2.0	28.0	—
M30 ×1.5	28.5	—
M30 ×1.0	29.0	—
M32 ×2.0	30.0	—
M32 ×1.5	30.5	—
M33 ×3.0	30.0	—
M33 ×2.0	31.0	—
M33 ×1.5	31.5	—
M35 ×1.5	33.5	—
M36 ×3.0	33.0	—
M36 ×2.0	34.0	—
M36 ×1.5	34.5	—
M38 ×1.5	36.5	—
M39 ×3.0	36.0	—
M39 ×2.0	37.0	—
M39 ×1.5	37.5	—
M40 ×3.0	37.0	—
M40 ×2.0	38.0	—
M40 ×1.5	38.5	—
M42 ×4.0	38.0	—

Nominal	Drill Diameter	
	HSS	Carbide
M42 ×3.0	39.0	—
M42 ×2.0	40.0	—
M42 ×1.5	40.5	—
M45 ×4.0	41.0	—
M45 ×3.0	42.0	—
M45 ×2.0	43.0	—
M45 ×1.5	43.5	—
M48 ×4.0	44.0	—
M48 ×3.0	45.0	—
M48 ×2.0	46.0	—
M48 ×1.5	46.5	—
M50 ×3.0	47.0	—
M50 ×2.0	48.0	—
M50 ×1.5	48.5	—

(Note) Hole sizes should be measured since the accuracy of a drilled hole may change due to the drilling conditions, and if found to be inappropriate for a tapping hole, the drill diameter must be corrected accordingly.

HEXAGON SOCKET HEAD BOLT HOLE SIZE • INTERNATIONAL SYSTEM OF UNITS

DIMENSIONS OF COUNTERBORING FOR HEXAGON SOCKET HEAD CAP SCREW AND BOLT HOLE Unit : mm

Nominal dimensions of thread d	M3	M4	M5	M6	M8	M10	M12	M14	M16	M18	M20	M22	M24	M27	M30
d₁	3	4	5	6	8	10	12	14	16	18	20	22	24	27	30
d'	3.4	4.5	5.5	6.6	9	11	14	16	18	20	22	24	26	30	33
D	5.5	7	8.5	10	13	16	18	21	24	27	30	33	36	40	45
D'	6.5	8	9.5	11	14	17.5	20	23	26	29	32	35	39	43	48
H	3	4	5	6	8	10	12	14	16	18	20	22	24	27	30
H'	2.7	3.6	4.6	5.5	7.4	9.2	11	12.8	14.5	16.5	18.5	20.5	22.5	25	28
H''	3.3	4.4	5.4	6.5	8.6	10.8	13	15.2	17.5	19.5	21.5	23.5	25.5	29	32

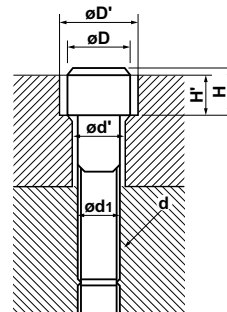
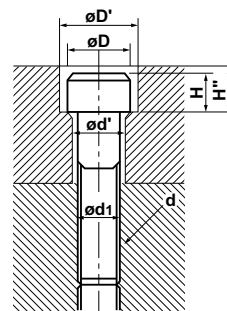

INTERNATIONAL SYSTEM OF UNITS

UNIT CONVERSION TABLE for EASIER CHANGE into SI UNITS (Bold type Indicates SI unit)

● **Pressure**

Pa	kPa	MPa	bar	kgf/cm ²	atm	mmH ₂ O	mmHg or Torr
1	1×10 ⁻³	1×10 ⁻⁶	1×10 ⁻⁵	1.01972×10 ⁻⁵	9.86923×10 ⁻⁶	1.01972×10 ⁻¹	7.50062×10 ⁻³
1×10 ³	1	1×10 ⁻³	1×10 ⁻²	1.01972×10 ⁻²	9.86923×10 ⁻³	1.01972×10 ²	7.50062
1×10 ⁶	1×10 ³	1	1×10	1.01972×10	9.86923	1.01972×10 ⁵	7.50062×10 ³
1×10 ⁵	1×10 ²	1×10 ⁻¹	1	1.01972	9.86923×10 ⁻¹	1.01972×10 ⁴	7.50062×10 ²
9.80665×10 ⁴	9.80665×10	9.80665×10 ⁻²	9.80665×10 ⁻¹	1	9.67841×10 ⁻¹	1×10 ⁴	7.35559×10 ²
1.01325×10 ⁵	1.01325×10 ²	1.01325×10 ⁻¹	1.01325	1.03323	1	1.03323×10 ⁴	7.60000×10 ²
9.80665	9.80665×10 ⁻³	9.80665×10 ⁻⁶	9.80665×10 ⁻⁵	1×10 ⁻⁴	9.67841×10 ⁻⁵	1	7.35559×10 ⁻²
1.33322×10 ²	1.33322×10 ⁻¹	1.33322×10 ⁻⁴	1.33322×10 ⁻³	1.35951×10 ⁻³	1.31579×10 ⁻³	1.35951×10	1

(Note) 1Pa=1N/m²

● **Force**

N	dyn	kgf
1	1×10 ⁵	1.01972×10 ⁻¹
1×10 ⁻⁵	1	1.01972×10 ⁻⁶
9.80665	9.80665×10 ⁵	1

● **Stress**

Pa	MPa or N/mm ²	kgf/mm ²	kgf/cm ²
1	1×10 ⁻⁶	1.01972×10 ⁻⁷	1.01972×10 ⁻⁵
1×10 ⁶	1	1.01972×10 ⁻¹	1.01972×10
9.80665×10 ⁶	9.80665	1	1×10 ²
9.80665×10 ⁴	9.80665×10 ⁻²	1×10 ⁻²	1

(Note) 1Pa=1N/m²

● **Work / Energy / Quantity of Heat**

J	kW·h	kgf·m	kcal
1	2.77778×10 ⁻⁷	1.01972×10 ⁻¹	2.38889×10 ⁻⁴
3.600 ×10 ⁶	1	3.67098×10 ⁵	8.6000 ×10 ²
9.80665	2.72407×10 ⁻⁶	1	2.34270×10 ⁻³
4.18605×10 ³	1.16279×10 ⁻³	4.26858×10 ²	1

(Note) 1J=1W·s, 1J=1N·m
1cal=4.18605J
(By the law of weights and measures)

● **Power (Rate of Production / Motive Power) / Heat Flow Rate**

W	kgf·m/s	PS	kcal/h
1	1.01972×10 ⁻¹	1.35962×10 ⁻³	8.6000 ×10 ⁻¹
9.80665	1	1.33333×10 ⁻²	8.43371
7.355 ×10 ²	7.5 ×10	1	6.32529×10 ²
1.16279	1.18572×10 ⁻¹	1.58095×10 ⁻³	1

(Note) 1W=1J/s, PS:French horse power
1PS=0.7355kW
1cal=4.18605J
(By the law of weights and measures)