



# TURNING TOOLS

# THREADING

CLASSIFICATION (EXTERNAL).....	A320
CLASSIFICATION (INTERNAL).....	A321
CROSS REFERENCE THREAD PITCH	
EXTERNAL.....	A322
INTERNAL.....	A324
STANDARD THREAD AND CORRESPONDING INSERT•HOLDER.....	A326
FEATURES OF MMT SERIES.....	A328

## STANDARD OF THREADING TOOLS

### EXTERNAL THREADING

MMTE HOLDER.....	A330
SET HOLDER.....	A340
MT HOLDER.....	A344
SMG HOLDER.....	A346

### INTERNAL THREADING

MMTI TYPE BORING BARS.....	A331
SNT TYPE BORING BARS.....	A342
MICRO-MINI TWIN BORING BARS.....	A348
F TYPE BORING BARS.....	A350
D TYPE BORING HEAD.....	A354

THREADING METHOD.....	A356
STANDARD OF DEPTH OF CUT.....	A360
TROUBLE SHOOTING.....	A364

# CLASSIFICATION (EXTERNAL)





CLASSIFICATION (EXTERNAL) THREADING

Name of Tool Holder	Insert Shape	Features	Shank Size (H x W x L)	
<p><b>MMTE</b> Holder</p>  <p>→ A330</p>		<ul style="list-style-type: none"> <li>● Various insert types.</li> <li>● Precision class insert.</li> <li>● Available with a wiper cutting edge to provide a precise thread geometry.</li> <li>● Able to change lead angle by replacing the shim.</li> </ul>	<p>12 x 12 x 100 16 x 16 x 100 20 x 20 x 125 25 x 25 x 150 32 x 32 x 170 40 x 40 x 200</p>	
<p><b>SET</b> Holder</p>  <p>→ A340</p>		<ul style="list-style-type: none"> <li>● Clamp-on type.</li> <li>● Various insert types.</li> <li>● Inserts with a chip breaker give excellent chip control.</li> </ul>	<p>16 x 16 x 100 20 x 20 x 125 25 x 25 x 150</p>	
<p><b>MT</b> Holder</p>  <p>→ A344</p>		<ul style="list-style-type: none"> <li>● Clamp-on type.</li> <li>● Precision class insert.</li> <li>● Positive insert suffers from negligible chattering and thus produces a good finished surface.</li> </ul>	<p>16 x 16 x 100 20 x 20 x 125 25 x 25 x 150 32 x 32 x 170</p>	
<p><b>SMG</b> Holder</p>  <p>→ A346</p>		<ul style="list-style-type: none"> <li>● Screw-on type.</li> <li>● Precision class insert.</li> <li>● Positive insert suffers from negligible chattering and thus produces a good finished surface.</li> <li>● Holder is capable of performing both threading and grooving.</li> </ul>	<p>10 x 10 x 70 12 x 12 x 80 16 x 16 x 100 20 x 20 x 125 25 x 25 x 150</p>	
SMALL TOOLS	<p><b>TTAH</b></p>  <p>→ A220</p>		<ul style="list-style-type: none"> <li>● Tools to be used on Gang type tool posts.</li> <li>● Small Shank : 8mm – 16mm</li> <li>● High rigidity vertical insert design.</li> <li>● The screw designed for common use on front and back enables back clamping.</li> <li>● Most suitable for threading diameters of 2mm or smaller.</li> <li>● Screw-on type.</li> </ul>	<p>8 x 10 x 120 10 x 10 x 120 12 x 12 x 120 16 x 16 x 120</p>
	<p><b>CSVH</b></p>  <p>→ A223</p>		<ul style="list-style-type: none"> <li>● Tools to be used on Cam type tool posts.</li> <li>● Small Shank : 7mm – 12mm</li> <li>● Single holder for front turning, back turning, grooving, threading and cutting off operations.</li> <li>● The most suitable for machining of small parts with diameter 5mm or less.</li> <li>● Screw-on type.</li> </ul>	<p>7 x 7 x 140 8 x 8 x 140 9.5 x 9.5 x 140 10 x 10 x 140 12 x 12 x 140</p>

# CLASSIFICATION (INTERNAL)

Name of Tool Holder	Insert Shape	Features	Shank Size (Dia. x L x Min. Cutting Dia.)
<b>MMTI</b>  → A331		<ul style="list-style-type: none"> <li>● Minimum cutting diameter 12mm.</li> <li>● Various insert types.</li> <li>● Precision class insert.</li> <li>● Available with a wiper cutting edge to provide a precise thread geometry.</li> <li>● Able to change lead angle by replacing shim.</li> </ul>	16 x 125 x 13 16 x 150 x 15 20 x 170 x 24 25 x 200 x 29 32 x 250 x 37 40 x 300 x 46
<b>SNT</b>  → A342		<ul style="list-style-type: none"> <li>● Minimum cutting diameter 12mm.</li> <li>● Screw-on type.</li> <li>● Various insert shapes and grades.</li> <li>● Inserts with a chip breaker give excellent chip control.</li> </ul>	16 x 125 x 12 20 x 150 x 19 25 x 170 x 24 25 x 200 x 29
<b>FSL5</b>  → A350		<ul style="list-style-type: none"> <li>● Minimum cutting diameter 10mm.</li> <li>● Screw-on type.</li> <li>● Precision class insert.</li> <li>● Applicable for threading, grooving and boring.</li> <li>● Available with a carbide shank to prevent vibration when machining deep holes.</li> </ul>	8 x 125 x 10 10 x 150 x 12 12 x 180 x 14 14 x 180 x 16 16 x 200 x 20
<b>FCL5</b>  → A352		<ul style="list-style-type: none"> <li>● Minimum cutting diameter 23mm.</li> <li>● Clamp-on type.</li> <li>● Precision class insert.</li> <li>● Applicable to threading and grooving.</li> </ul>	16 x 200 x 23 20 x 200 x 29 25 x 250 x 34 32 x 300 x 40
<b>DPT2</b>  → A354		<ul style="list-style-type: none"> <li>● Minimum cutting diameter 40mm.</li> <li>● Pin lock type.</li> <li>● Precision class insert.</li> <li>● Exchangeable head type.</li> </ul>	32 x 300 x 40 40 x 360 x 50
<b>MICRO-MINI TWIN Boring Bars</b>  → A348	—	<ul style="list-style-type: none"> <li>● Minimum cutting diameter 3mm.</li> <li>● Solid carbide type.</li> <li>● Economical two cutting edges type.</li> </ul>	3 x 50 x 3 4 x 60 x 4.5 5 x 70 x 6 6 x 75 x 7
<b>MICRO-MINI Boring Bars</b>  → A247	—	<ul style="list-style-type: none"> <li>● Minimum cutting diameter 3.2mm.</li> <li>● Solid carbide type.</li> <li>● Insert can be ground to suit the application.</li> </ul>	3 x 80 x 3.2 4 x 80 x 4.2 5 x 100 x 5.2







# CROSS REFERENCE THREAD PITCH (EXTERNAL)

Application		General machining				Pipe fittings and couplings for gas and water	
Type	Partial Profile 60°	Partial Profile 55°	ISO Metric	American UN	Parallel Pipe Thread Whitworth for BSW, BSP	American NPT	
Symbol	M UNC UNF	W	M	UNC UNF	G Rp W	NPT	
Pitch	mm (thread/inch)	thread/inch	mm	thread/inch	thread/inch	thread/inch	
<b>MMT</b> Holder  A330	Full form	—	—	0.5–5.0	32–5	28–5	27,18,14 11.5,8
	Partial form	0.5–5.0 (48–5)	48–5	0.5–5.0	48–5	—	—
<b>SET</b> Holder  A340	Full form	—	—	1.0–3.0	24,20 16,14,12	19,14,12,11	—
	Partial form	0.5–3.0 (48–8)	48–8	0.5–3.0	48–8	—	—
<b>MT</b> Holder  A344	Partial form	0.25–4.5 (64–6)	20–9	0.25–4.5	64–6	—	—
<b>SMG</b> Holder  A346	Partial form	0.25–2.0 (48–13)	—	0.25–2.0	48–13	—	—

CROSS REFERENCE THREAD PITCH (EXTERNAL) THREADING

	Steam, gas and water pipes		Pipe couplings for food and fire fighting industries	Motion transmissions		Aircraft and aerospace	Oil and gas	
	Taper Pipe Thread BSPT	American NPTF	Round DIN 405	ISO Trapezoidal 30°	American ACME	UNJ	API Buttress Casing	API Round Casing&Tubing
	R Rc	NPTF	Rd	Tr	ACME	UNJ	BCSG	CSG LCSG
	thread/inch	thread/inch	thread/inch	mm	thread/inch	thread/inch	thread/inch	thread/inch
	28,19,14,11	27,18,14 11.5,8	10,8,6,4	1.5,2,3,4,5	12,10,8,6,5	32-8	5	10,8
	-	-	-	-	-	-	-	-
	19,14,11	-	-	-	-	-	-	-
	-	-	-	-	-	-	-	-
	-	-	-	-	-	-	-	-
	-	-	-	-	-	-	-	-

# CROSS REFERENCE THREAD PITCH (INTERNAL)

Application		General machining				Pipe fittings and couplings for gas and water	
Type		Partial Profile 60°	Partial Profile 55°	ISO Metric	American UN	Parallel Pipe Thread Whitworth for BSW, BSP	American NPT
Symbol		M UNC UNF	W	M	UNC UNF	G Rp W	NPT
Pitch		mm (thread/inch)	thread/inch	mm	thread/inch	thread/inch	thread/inch
<b>MMT</b> Boring Bar  A331	Full form	—	—	0.5–5.0	32–5	28–5	27,18,14 11.5,8
	Partial form	0.5–5.0 (48–5)	48–5	0.5–5.0	48–5	—	—
<b>SNT</b> Boring Bar  A342	Full form	—	—	1.0–3.0	24,20 16,14,12	19,14,12,11	—
	Partial form	0.5–3.0 (48–8)	48–8	0.5–3.0	48–8	—	—
<b>FSL5</b> Boring Bar  A350	Partial form	1.5–3.5 (16–8)	—	1.5–3.5	16–8	—	—
<b>FCL5</b> Boring Bar  A352	Partial form	0.25–2.5 (64–11)	—	0.25–2.5	64–11	—	—
<b>DPT2</b> Boring Head  A354	Partial form	0.25–4.5 (64–6)	—	0.25–4.5	64–6	—	—
<b>MICRO-MINI TWIN</b>  A348	Partial form	0.5–1.75 (36–16)	—	0.5–1.75	36–16	—	—

CROSS REFERENCE THREAD PITCH (INTERNAL) THREADING

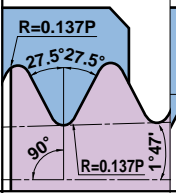
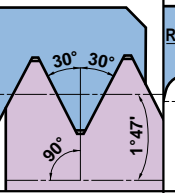
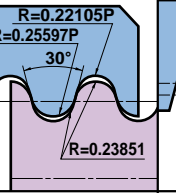
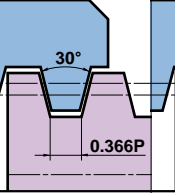
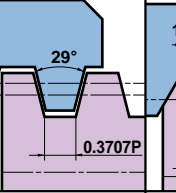
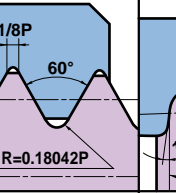
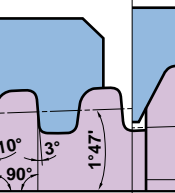
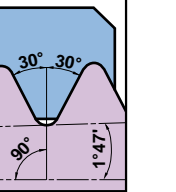
	Steam, gas and water pipes		Pipe couplings for food and fire fighting industries	Motion transmissions		Aircraft and aerospace	Oil and gas	
	Taper Pipe Thread BSPT	American NPTF	Round DIN 405	ISO Trapezoidal 30°	American ACME	UNJ	API Buttress Casing	API Round Casing&Tubing
								
	R Rc	NPTF	Rd	Tr	ACME	UNJ	BCSG	CSG LCSG
	thread/inch	thread/inch	thread/inch	mm	thread/inch	thread/inch	thread/inch	thread/inch
	28,19,14,11	14,11,5,8	10,8,6,4	1.5,2,3,4,5	12,10,8,6,5	—	5	10,8
	—	—	—	—	—	*	—	—
	19,14,11	—	—	—	—	—	—	—
	—	—	—	—	—	—	—	—
	—	—	—	—	—	—	—	—
	—	—	—	—	—	—	—	—
	—	—	—	—	—	—	—	—
	—	—	—	—	—	—	—	—
	—	—	—	—	—	—	—	—

\* When machining an internal UNJ thread, cut an internal hole with the appropriate diameter. Then machine with 60° American UN. In this case, a full form type insert cannot be used.

# STANDARD THREAD AND CORRESPONDING INSERT•HOLDER

STANDARD THREAD AND CORRESPONDING INSERT•HOLDER | THREADING

Thread Name	Standard Thread Type	Type	Ext./Int.	Insert Number	Wiper/General	Tool Holder	Page		
ISO Metric	<p> <math>H=0.866025P</math> <math>d_2=d-0.649519P</math>  <math>H_1=0.541266P</math> <math>d_1=d-1.082532P</math>  <math>D=d</math> <math>D_2=d_2</math> <math>D_1=d_1</math> </p>	M	Ext.	MMT $\circ\circ$ ER $\circ\circ\circ$ ISO	Wiper	MMTER $\circ\circ\circ\circ\circ$ -C	A330		
				MMT $\circ\circ$ ER $\circ\circ\circ$ ISO-S	Wiper				
				MMT $\circ\circ$ ER $\circ\circ\circ$ 60	General				
				MMT $\circ\circ$ ER $\circ\circ\circ$ 60-S	General				
				SET $\circ\circ\circ$ R3XMM	Wiper			SETHR $\circ\circ\circ\circ\circ$ 16	A340
				SET $\circ\circ\circ$ R3XMM	General				
				SMTTR/L160360 $\circ\circ$	General			SMGHR/L $\circ\circ\circ\circ\circ$ 16	A346
			Int.	MTTR/L4360 $\circ\circ$	General	MTHR/L $\circ\circ\circ\circ\circ$ 4	A344		
				MTTR/L4360 $\circ\circ$	General	MT1R/L $\circ\circ\circ\circ\circ$ 4	A344		
				MMT $\circ\circ$ IR $\circ\circ\circ$ ISO	Wiper	MMTIR $\circ\circ\circ$ A $\circ\circ\circ$ -SP $\circ$	A331		
				MMT $\circ\circ$ IR $\circ\circ\circ$ ISO-S	Wiper				
				MMT $\circ\circ$ IR $\circ\circ\circ$ 60	General	MMTIR $\circ\circ\circ$ A $\circ$ 16-C	A331		
				MMT $\circ\circ$ IR $\circ\circ\circ$ 60-S	General				
				SNT $\circ\circ\circ$ R3XMM	Wiper	SNTF $\circ\circ\circ$ R	A342		
SNT $\circ\circ\circ$ R3XMM	General	DPT2 $\circ\circ\circ$ R	A354						
MTTR/L4360 $\circ\circ$	General	FCL51 $\circ\circ$ R/L	A352						
American UN	<p> <math>H=0.866025 \times 25.4/n</math> <math>d_2=(d-0.649519/n) \times 25.4</math>  <math>H_1=0.541266 \times 25.4/n</math> <math>d_1=(d-1.082532/n) \times 25.4</math>  <math>d=(d) \times 25.4</math> <math>D=d</math> <math>D_2=d_2</math> <math>D_1=d_1</math> <math>P=25.4/\text{thread}</math> </p>	UNC UNF	Ext.	MMT $\circ\circ$ ER $\circ\circ\circ$ UN	Wiper	MMTER $\circ\circ\circ\circ\circ$ -C	A330		
				MMT $\circ\circ$ ER $\circ\circ\circ$ UN-S	Wiper				
				MMT $\circ\circ$ ER $\circ\circ\circ$ 60	General				
				MMT $\circ\circ$ ER $\circ\circ\circ$ 60-S	General				
				SET $\circ\circ\circ$ R3XMUN	Wiper			SETHR $\circ\circ\circ\circ\circ$ 16	A340
				SET $\circ\circ\circ$ R3XMM	General			SMGHR/L $\circ\circ\circ\circ\circ$ 16	A346
				SMTTR/L160360 $\circ\circ$	General			MTHR/L $\circ\circ\circ\circ\circ$ 4	A344
			Int.	MTTR/L4360 $\circ\circ$	General	MT1R/L $\circ\circ\circ\circ\circ$ 4	A344		
				MMT $\circ\circ$ IR $\circ\circ\circ$ UN	Wiper	MMTIR $\circ\circ\circ$ A $\circ\circ\circ$ -SP $\circ$	A331		
				MMT $\circ\circ$ IR $\circ\circ\circ$ UN-S	Wiper				
				MMT $\circ\circ$ IR $\circ\circ\circ$ 60	General	MMTIR $\circ\circ\circ$ A $\circ$ 16-C	A331		
				MMT $\circ\circ$ IR $\circ\circ\circ$ 60-S	General				
				SNT $\circ\circ\circ$ R3XMUN	Wiper	SNTF $\circ\circ\circ$ R	A342		
				SNT $\circ\circ\circ$ R3XMM	General	DPT2 $\circ\circ\circ$ R	A354		
MTTR/L4360 $\circ\circ$	General	FCL51 $\circ\circ$ R/L	A352						
Whitworth for BSW, BSP	<p> <math>H=0.9605P</math> <math>d_2=d-H_1</math> <math>d_1=d-2H_1</math> <math>r=0.1373P</math>  <math>H_1=0.6403P</math> <math>D_1=d_1+2 \times 0.0769H</math>  <math>D=d</math> <math>D_2=d_2</math> <math>D_1=d_1</math> <math>P=25.4/\text{thread}</math> </p>	W	Ext.	MMT $\circ\circ$ ER $\circ\circ\circ$ W	Wiper	MMTER $\circ\circ\circ\circ\circ$ -C	A330		
				MMT $\circ\circ$ ER $\circ\circ\circ$ W-S	Wiper				
				MMT $\circ\circ$ ER $\circ\circ\circ$ 55	General				
				MMT $\circ\circ$ ER $\circ\circ\circ$ 55-S	General				
				SET $\circ\circ\circ$ R3XMP	Wiper			SETHR $\circ\circ\circ\circ\circ$ 16	A340
				SET $\circ\circ\circ$ R3XMP	General			MTHR/L $\circ\circ\circ\circ\circ$ 4	A344
				MTTR/L4355 $\circ\circ$	General			MT1R/L $\circ\circ\circ\circ\circ$ 4	A344
			Int.	MMT $\circ\circ$ IR $\circ\circ\circ$ W	Wiper	MMTIR $\circ\circ\circ$ A $\circ\circ\circ$ -SP $\circ$	A331		
				MMT $\circ\circ$ IR $\circ\circ\circ$ W-S	Wiper				
				MMT $\circ\circ$ IR $\circ\circ\circ$ 55	General	MMTIR $\circ\circ\circ$ A $\circ$ 16-C	A331		
				MMT $\circ\circ$ IR $\circ\circ\circ$ 55-S	General				
				SNT $\circ\circ\circ$ R3XMP	Wiper	SNTF $\circ\circ\circ$ R	A342		
				SNT $\circ\circ\circ$ R3XMP	General	DPT2 $\circ\circ\circ$ R	A354		
				MTTR/L4355 $\circ\circ$	General				

Wiper : Insert order number is determined by selected pitch.  
 General : An insert is applicable to several pitch types.

Thread Name	Standard Thread Type	Type	Ext./Int.	Insert Number	Wiper/General	Tool Holder	Page
Parallel Pipe Thread	<p>H=0.960491P d<sub>2</sub>=d-h d<sub>1</sub>=d-2h r=0.137329P h=0.640327 D=D d<sub>2</sub>=d<sub>2</sub> D<sub>1</sub>=d<sub>1</sub> 25.4/thread</p>	PF G Rp	Ext.	MMT $\odot\odot\odot$ ER $\odot\odot\odot$ W	Wiper	MMTER $\odot\odot\odot\odot\odot\odot$ -C	A330
				MMT $\odot\odot\odot$ ER $\odot\odot\odot$ W-S	Wiper		A340
			Int.	SET $\odot\odot\odot$ OR3XMP	Wiper	SETHR $\odot\odot\odot\odot\odot\odot$ 16	A331
				MMT $\odot\odot\odot$ IR $\odot\odot\odot$ W	Wiper	MMTIR $\odot\odot\odot$ A $\odot\odot\odot$ -SP $\odot$	A342
				MMT $\odot\odot\odot$ IR $\odot\odot\odot$ W-S	Wiper	MMTIR $\odot\odot\odot$ A $\odot$ 16-C	
				SNT $\odot\odot\odot$ OR3XMP	Wiper	SNTF $\odot\odot\odot$ OR	
BSPT	<p>H=0.960237P h=0.640327 r=0.137278P P=25.4/thread</p>	BSPT	Ext.	MMT $\odot\odot\odot$ ER $\odot\odot\odot$ BSPT	Wiper	MMTER $\odot\odot\odot\odot\odot\odot$ -C	A330
				MMT $\odot\odot\odot$ ER $\odot\odot\odot$ BSPT-S	Wiper		A340
			Int.	SET $\odot\odot\odot$ OR3XMPT	Wiper	SETHR $\odot\odot\odot\odot\odot\odot$ 16	A331
				MMT $\odot\odot\odot$ IR $\odot\odot\odot$ BSPT	Wiper	MMTIR $\odot\odot\odot$ A $\odot\odot\odot$ -SP $\odot$	A342
				MMT $\odot\odot\odot$ IR $\odot\odot\odot$ BSPT-S	Wiper	MMTIR $\odot\odot\odot$ A $\odot$ 16-C	
				SNT $\odot\odot\odot$ OR3XMPT	Wiper	SNTF $\odot\odot\odot$ OR	
Round DIN 405	<p>ac=0.05xP h<sub>3</sub>=H<sub>4</sub>=0.5xP R<sub>1</sub>=0.238507xP R<sub>2</sub>=0.255967xP R<sub>3</sub>=0.221047xP</p>	Rd	Ext.	MMT $\odot\odot\odot$ ER $\odot\odot\odot$ RD	Wiper	MMTER $\odot\odot\odot\odot\odot\odot$ -C	A330
			Int.	MMT $\odot\odot\odot$ IR $\odot\odot\odot$ RD	Wiper	MMTIR $\odot\odot\odot$ A $\odot\odot\odot$ -SP $\odot$ MMTIR $\odot\odot\odot$ A $\odot$ 16-C	A331
ISO Trapezoidal 30°		Tr	Ext.	MMT $\odot\odot\odot$ ER $\odot\odot\odot$ TR	Wiper	MMTER $\odot\odot\odot\odot\odot\odot$ -C	A330
			Int.	MMT $\odot\odot\odot$ IR $\odot\odot\odot$ TR	Wiper	MMTIR $\odot\odot\odot$ A $\odot\odot\odot$ -SP $\odot$ MMTIR $\odot\odot\odot$ A $\odot$ 16-C	A331
American ACME		ACME	Ext.	MMT $\odot\odot\odot$ ER $\odot\odot\odot$ ACME	Wiper	MMTER $\odot\odot\odot\odot\odot\odot$ -C	A330
			Int.	MMT $\odot\odot\odot$ IR $\odot\odot\odot$ TACME	Wiper	MMTIR $\odot\odot\odot$ A $\odot\odot\odot$ -SP $\odot$ MMTIR $\odot\odot\odot$ A $\odot$ 16-C	A331
American NPT	<p>H=0.866025P h=0.800000p</p>	NPT	Ext.	MMT $\odot\odot\odot$ ER $\odot\odot\odot$ NPT	Wiper	MMTER $\odot\odot\odot\odot\odot\odot$ -C	A330
			Int.	MMT $\odot\odot\odot$ IR $\odot\odot\odot$ NPT	Wiper	MMTIR $\odot\odot\odot$ A $\odot\odot\odot$ -SP $\odot$ MMTIR $\odot\odot\odot$ A $\odot$ 16-C	A331

Wiper : Insert order number is determined by selected pitch.  
General : An insert is applicable to several pitch types.

# FEATURES OF MMT SERIES

## A WIDE VARIETY OF PRODUCTS

Mitsubishi Miracle Threading (MMT) series. 283 inserts and 26 holders.

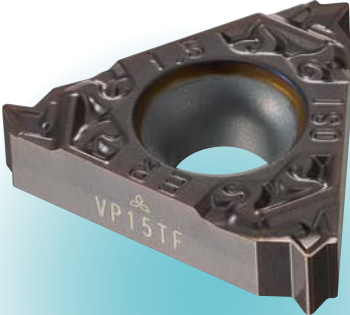
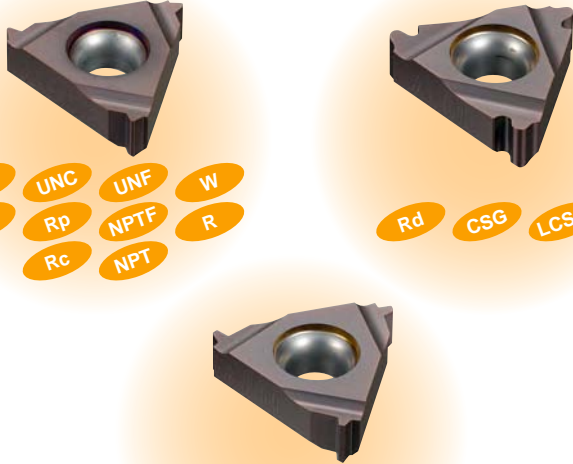
M-CLASS INSERTS WITH 3-D CHIP BREAKERS	G-CLASS GROUND INSERTS
 <p>VP15TF</p> <p>M UNC UNF W G Rp R Rc</p>	 <p>M UNC UNF W G Rp NPTF R Rc NPT</p> <p>Rd CSG LCSG</p> <p>Tr ACME BCSG</p>

FEATURES OF MMT SERIES | THREADING

## IDEAL CHIP CONTROL EVEN IN THE LATTER HALF OF PASSES WHEN CONTINUOUS CHIPS ARE USUALLY PRODUCED. (M-CLASS INSERTS WITH 3-D CHIP BREAKERS)

ISO metric external thread pitch 1.5mm Final pass (6th pass)

Competitor	MMT
	

<Cutting Conditions>  
 Workpiece : DIN 41CrMo4  
 Insert : MMT16ER150ISO-S  
 Grade : VP15TF  
 Cutting speed : 120m/min  
 Cutting method : Radial Infeed  
 Depth of cut : Fixed cut area  
 Pass : 6 times  
 Coolant : Wet

## A HIGHER LEVEL OF PRECISION THAN CONVENTIONAL INSERTS (G-CLASS GROUND INSERTS)

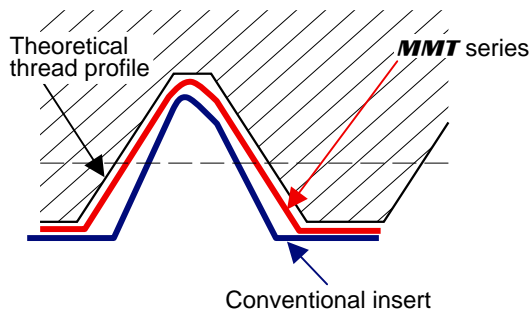

High precision threading can be achieved by using MMT inserts that feature a ground rake face and peripheral cutting edge.

Thread Type	Threading Tolerance
ISO Metric	6g / 6H
American UN	2A / 2B
Whitworth for BSW, BSP	Medium Class A
BSPT	Standard BSPT
Round DIN 405	7h / 7H
ISO Trapezoidal 30°	7e / 7H
American ACME	3G
UNJ	3A
API Buttress Casing	Standard API
API Rounded Casing & Tubing	Standard API RD
American NPT	Standard NPT
American NPTF	Class2

## ■ HOLDER (Use of special surface treatment)

### External

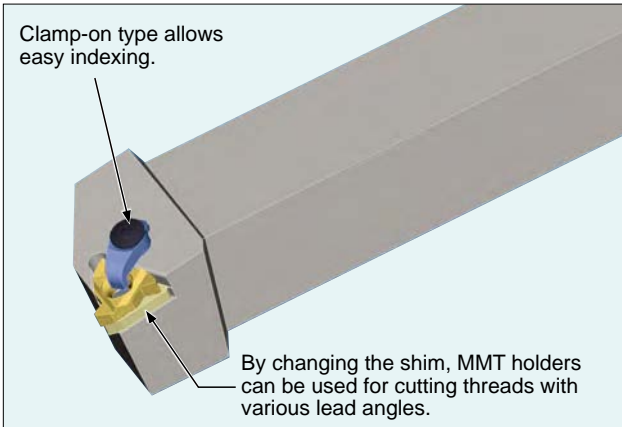

### Internal

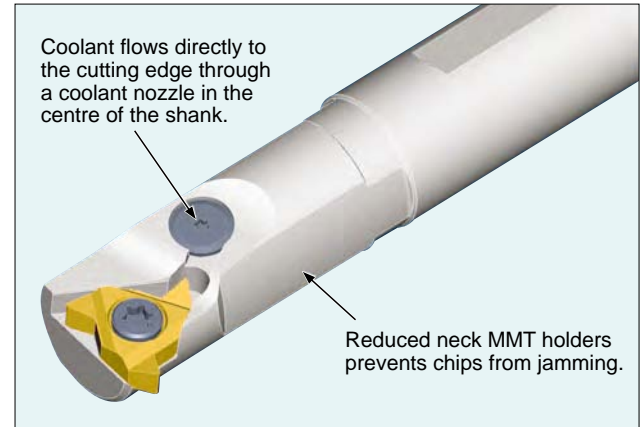

## ■ SUITABLE FOR THREADING WITH A LARGE LEAD ANGLE

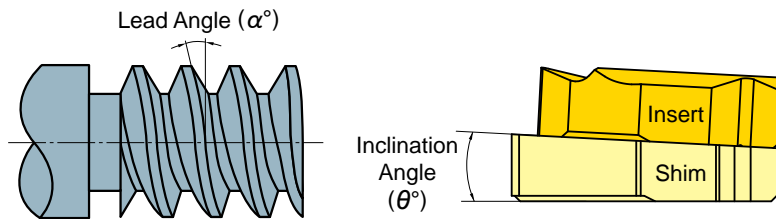

By changing only the shim, MMT holders can be used for turning of threads with various lead angles as well as the turning of left hand threads. (Please refer to page A356 and page A359)

Lead Angle ( $\alpha^\circ$ )	Inclination Angle ( $\theta^\circ$ )
-1.5°	-3°
-0.5°	-2°
0.5°	-1°
1.5°	0°
2.5°	1°
3.5°	2°
4.5°	3°

Standard shim delivered with the holder.

## ■ **VP10MF** (G-class ground insert only)

### ● Superior wear and plastic deformation resistance

- High wear and plastic deformation resistance for threading when maintaining the thread form is important. Suitable for continuous high precision machining with extensive tool life.
- Effective in combination with G-class inserts for high precision threading.

## ■ **VP15TF** (G-class ground insert, M-class inserts with 3-D chip breakers)

### ● Wide versatility

- High fracture resistance during low rigidity applications such as bar feed machining. Able to withstand harsh conditions for long periods where conventional inserts would be liable to breakage.
- Effective combination of high cost performance M-class inserts with 3-D chip breakers.

## ■ CHOOSING M-CLASS INSERTS WITH 3-D CHIP BREAKERS OR G-CLASS INSERTS

Insert	Chip control	Precision of thread
M-class inserts with 3-D chip breakers 	◎	○

Insert	Chip control	Precision of thread
G-class inserts 	○	◎

- For ideal chip control and a high cost performance ratio, M-class inserts with 3-D chip breakers are recommended.
- G-class inserts are recommended where higher precision is required.

# EXTERNAL THREADING

# MMTE HOLDER

- Various insert types.
- Precision class insert.
- Available with a wiper cutting edge to provide a precise thread geometry.
- Able to change lead angle by replacing shim.

## MMTE

### External threading

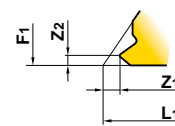
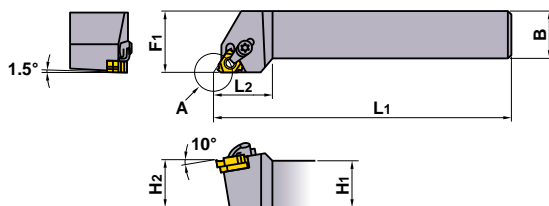
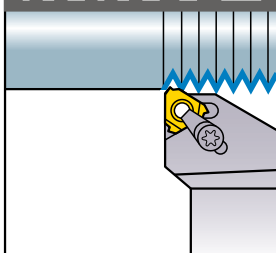

Details of position A  
Refer to page A332–A338  
for size Z1, Z2.

Right hand tool holder only.

Order Number	Stock R	Insert Number	Dimensions (mm)							Clamp Bridge	Clamp Screw	Stop Ring	Shim Screw	Shim	Wrench
			H1	B	L1	L2	H2	F1							
<b>MMTER1212H16-C</b>	●	MMT16ER ○○○○○	12	12	100	25	12	16	SETK51	SETS51	CR4	HFC03008	CTE32TP15	①TKY15F ②HKY20R	
<b>1616H16-C</b>	●		16	16	100	25	16	20	SETK51	SETS51	CR4	HFC03008	CTE32TP15	①TKY15F ②HKY20R	
<b>2020K16-C</b>	●		20	20	125	26	20	25	SETK51	SETS51	CR4	HFC03008	CTE32TP15	①TKY15F ②HKY20R	
<b>2525M16-C</b>	●		25	25	150	28	25	32	SETK51	SETS51	CR4	HFC03008	CTE32TP15	①TKY15F ②HKY20R	
<b>3232P16-C</b>	●		32	32	170	32	32	40	SETK51	SETS51	CR4	HFC03008	CTE32TP15	①TKY15F ②HKY20R	
<b>MMTER2525M22-C</b>	●	MMT22ER ○○○○○	25	25	150	32	25	32	SETK61	SETS61	CR5	HFC04010	CTE43TP15	①TKY20F ②HKY25R	
<b>3232P22-C</b>	●		32	32	170	32	32	40	SETK61	SETS61	CR5	HFC04010	CTE43TP15	①TKY20F ②HKY25R	
<b>4040R22-C</b>	●		40	40	200	38	40	50	SETK61	SETS61	CR5	HFC04010	CTE43TP15	①TKY20F ②HKY25R	

(Note) Select and use a shim as shown below (sold separately), dependant on the lead angle.

## SHIM

Lead Angle (α°)	Order Number	Stock R	Inclination Angle (θ°)	Applicable Holder
-1.5°	<b>CTE32TN15</b>	●	-3°	MMTER 16-C ○○○○○
-0.5°	<b>N05</b>	●	-2°	
0.5°	<b>P05</b>	●	-1°	
1.5°	<b>P15</b>	●	0°	
2.5°	<b>P25</b>	●	1°	
3.5°	<b>P35</b>	●	2°	
4.5°	<b>P45</b>	●	3°	

Lead Angle (α°)	Order Number	Stock R	Inclination Angle (θ°)	Applicable Holder
-1.5°	<b>CTE43TN15</b>	●	-3°	MMTER 22-C ○○○○○
-0.5°	<b>N05</b>	●	-2°	
0.5°	<b>P05</b>	●	-1°	
1.5°	<b>P15</b>	●	0°	
2.5°	<b>P25</b>	●	1°	
3.5°	<b>P35</b>	●	2°	
4.5°	<b>P45</b>	●	3°	

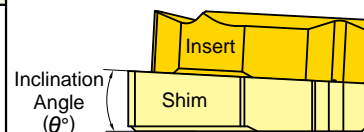

Standard shim delivered with the holder.

## IDENTIFICATION

**MMT E R 12 12 H 16 - C**

<b>Designation</b>	<b>Application</b> E External	<b>Hand of Tool</b> R Right	<b>Tool Size (mm) (Height and Width)</b> 12 12 16 16 20 20 25 25 32 32 40 40	<b>Tool Length (mm)</b> H 100 K 125 M 150 P 170 R 200	<b>Insert Size (mm)</b> 16 9.525 22 12.7	<b>Method of Holding</b> C Clamp-on
--------------------	----------------------------------	--------------------------------	--	--	--	--

## RECOMMENDED CUTTING CONDITIONS

	Work Material	Hardness	Grade	Cutting Speed (m/min)
<b>P</b>	Mild Steel	≤180HB	VP10MF	150 (70–230)
			VP15TF	100 (60–140)
	Carbon Steel • Alloy Steel	180–280HB	VP10MF	140 (80–200)
<b>M</b>	Stainless Steel	≤200HB	VP10MF	130 (80–180)
			VP15TF	80 (40–120)
<b>K</b>	Cast Iron	Tensile Strength ≤350N/mm <sup>2</sup>	VP10MF	140 (80–200)
			VP15TF	90 (60–120)

	Work Material	Hardness	Grade	Cutting Speed (m/min)
<b>S</b>	Heat-Resistant Alloy	—	VP10MF	45 (15–70)
			VP15TF	30 (20–40)
<b>H</b>	Titanium Alloy	—	VP10MF	60 (40–80)
			VP15TF	45 (25–65)
<b>H</b>	Heat-Treated Alloy	45–55HRC	VP10MF	50 (30–70)
			VP15TF	40 (20–60)

● : Inventory maintained. ★ : Inventory maintained in Japan.

# INTERNAL THREADING

## MMTI TYPE BORING BARS

- Minimum cutting diameter 13mm.
- Various insert types.
- Precision class insert.
- Available with a wiper cutting edge to provide a precise thread geometry.
- Able to change lead angle by replacing shim.

### MMTI

#### Internal threading

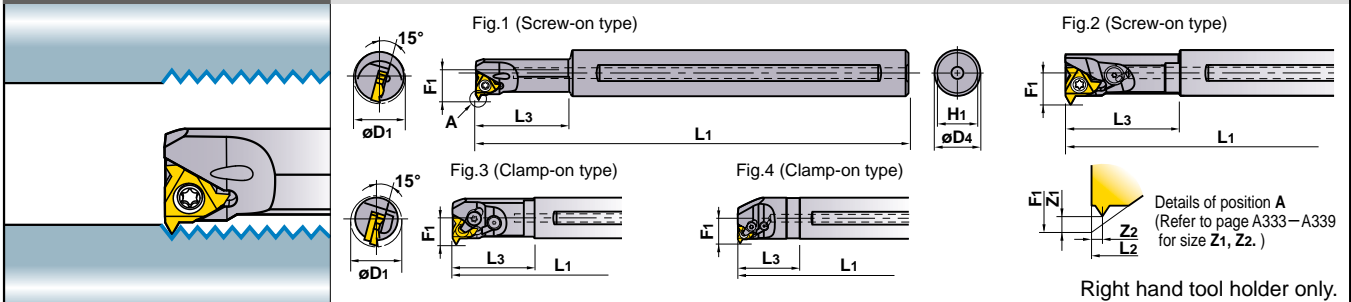

Order Number	Stock R	Insert Number	Lead Angle	Dimensions (mm)					Min. Cutting Diameter D1	Right hand tool holder only.						Fig
				D4	L1	L3	F1	H1		Clamp Bridge	Clamp Screw	Stop Ring	Shim Screw	Shim*	Wrench	
MMTIR1316AK11-SP15	●	MMT11IR	1.5°	16	125	25	8.7	15	13	—	TS25	—	—	—	⊙TKY08F	1
1316AK11-SP25	★		2.5°	16	125	25	8.7	15	13	—	TS25	—	—	—	⊙TKY08F	1
1316AK11-SP35	★		3.5°	16	125	25	8.7	15	13	—	TS25	—	—	—	⊙TKY08F	1
1516AM11-SP15	●		1.5°	16	150	32	9.7	15	15	—	TS25	—	—	—	⊙TKY08F	1
1516AM11-SP25	●		2.5°	16	150	32	9.7	15	15	—	TS25	—	—	—	⊙TKY08F	1
1516AM11-SP35	★		3.5°	16	150	32	9.7	15	15	—	TS25	—	—	—	⊙TKY08F	1
MMTIR1916AM16-SP15	●	MMT16IR	1.5°	16	150	40	12.2	15	19	—	CS350860T	—	—	—	⊙TKY15F	2
1916AM16-SP25	★		2.5°	16	150	40	12.2	15	19	—	CS350860T	—	—	—	⊙TKY15F	2
1916AM16-SP35	★		3.5°	16	150	40	12.2	15	19	—	CS350860T	—	—	—	⊙TKY15F	2
2420AQ16-C	●		1.5°	20	180	40	14.2	19	24	SETK51	SETS51	CR4	HFC03006	CTI32TP15	⊙TKY15F ⊙HKY20R	3
2925AS16-C	●		1.5°	25	250	60	16.7	23.4	29	SETK51	SETS51	CR4	HFC03006	CTI32TP15	⊙TKY15F ⊙HKY20R	3
3732AS16-C	●		1.5°	32	250	48	20.5	30.4	37	SETK51	SETS51	CR4	HFC03006	CTI32TP15	⊙TKY15F ⊙HKY20R	4
MMTIR2420AQ22-SP15	●	MMT22IR	1.5°	20	180	50	15.5	19	24	—	TS43	—	—	—	⊙TKY15F	2
2420AQ22-SP25	★		2.5°	20	180	50	15.5	19	24	—	TS43	—	—	—	⊙TKY15F	2
2420AQ22-SP35	★		3.5°	20	180	50	15.5	19	24	—	TS43	—	—	—	⊙TKY15F	2
3025AR22-C	●		1.5°	25	200	38	17.8	23.4	30	SETK61	SETS61	CR5	HFC04008	CTI43TP15	⊙TKY20F ⊙HKY25R	4
3832AS22-C	●		1.5°	32	250	48	21.8	30.4	38	SETK61	SETS61	CR5	HFC04008	CTI43TP15	⊙TKY20F ⊙HKY25R	4
4640AT22-C	★		1.5°	40	300	60	26.2	38	46	SETK61	SETS61	CR5	HFC04008	CTI43TP15	⊙TKY20F ⊙HKY25R	4

(Note) Select and use a shim as shown below (sold separately), dependant on the lead angle.  
 • A screw-on tool holder uses no shim. (The holder body has a lead angle.) Use a tool holder with the appropriate lead angle.  
 • Min. cutting diameter shows the internal hole diameter, not the thread diameter.

### SHIM

Lead Angle (α°)	Order Number	Stock R	Inclination Angle (θ°)	Applicable Holder
-1.5°	CTI32TN15	●	-3°	MMTIR ○○○ ○○16-C
-0.5°	N05	●	-2°	
0.5°	P05	●	-1°	
1.5°	P15	●	0°	
2.5°	P25	●	1°	
3.5°	P35	●	2°	
4.5°	P45	●	3°	○○22-C

Standard shim delivered with the holder.

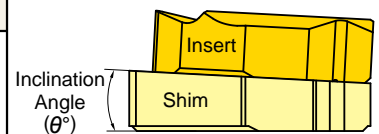

### IDENTIFICATION

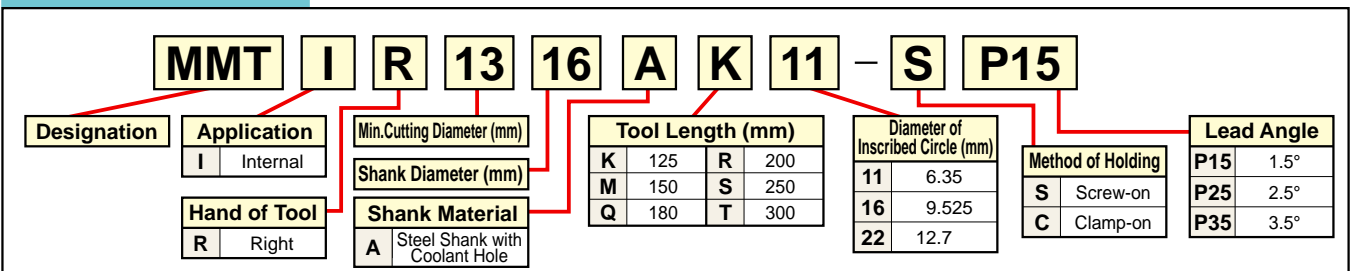

MMTI TYPE BORING BARS THREADING

# MMT M-CLASS INSERTS WITH 3-D CHIP BREAKERS

## EXTERNAL

Type	Order Number	Coated VP15TF	Pitch		Dimensions (mm)					Total Cutting Depth (mm)	Geometry
			mm	thread/inch	D1	S1	Z1	Z2	Re		
Partial Profile 60°	MMT16ERA60-S	●	0.5-1.5	48-16	9.525	3.44	0.8	0.9	0.06	-	
	16ERG60-S	●	1.75-3.0	14-8	9.525	3.44	1.2	1.7	0.23	-	
Partial Profile 55°	MMT16ERA55-S	●		48-16	9.525	3.44	0.8	0.9	0.07	-	
	16ERG55-S	●		14-8	9.525	3.44	1.2	1.7	0.23	-	
ISO Metric	MMT16ER100ISO-S	●	1.0		9.525	3.44	0.7	0.7	0.13	0.61	
	16ER125ISO-S	●	1.25		9.525	3.44	0.8	0.9	0.16	0.77	
	16ER150ISO-S	●	1.5		9.525	3.44	0.8	1.0	0.20	0.92	
	16ER175ISO-S	●	1.75		9.525	3.44	0.9	1.2	0.22	1.07	
	16ER200ISO-S	●	2.0		9.525	3.44	1.0	1.3	0.26	1.23	
	16ER250ISO-S	●	2.5		9.525	3.44	1.1	1.5	0.33	1.53	
	16ER300ISO-S	●	3.0		9.525	3.44	1.2	1.6	0.40	1.84	
American UN	MMT16ER160UN-S	●		16	9.525	3.44	0.9	1.1	0.23	0.97	
	16ER140UN-S	●		14	9.525	3.44	1.0	1.2	0.26	1.11	
	16ER120UN-S	●		12	9.525	3.44	1.1	1.4	0.30	1.30	
Whitworth for BSW, BSP	MMT16ER190W-S	●		19	9.525	3.44	0.8	1.0	0.18	0.86	
	16ER140W-S	●		14	9.525	3.44	1.0	1.2	0.25	1.16	
	16ER110W-S	●		11	9.525	3.44	1.1	1.5	0.32	1.48	
BSPT	MMT16ER190BSPT-S	●		19	9.525	3.44	0.8	0.9	0.18	0.86	
	16ER140BSPT-S	●		14	9.525	3.44	1.0	1.2	0.25	1.16	
	16ER110BSPT-S	●		11	9.525	3.44	1.1	1.5	0.32	1.48	

## IDENTIFICATION

**MMT 16 ER 050 ISO - S** — S M-class inserts with 3-D chip breakers

<b>Designation</b>	<b>Hand of Tool</b>	<b>Pitch</b>	<b>Threading Type</b>
Diameter of Inscribed Circle (mm) 11 6.35 16 9.525	Application E External I Internal	R Right	60 Partial Profile 60° 55 Partial Profile 55° ISO ISO Metric W Whitworth for BSW, BSP BSPT BSPT UN American UN
			100 1.0mm 125 1.25mm 150 1.5mm 175 1.75mm 200 2.0mm 250 2.5mm 300 3.0mm

**A** 0.5-1.5mm or 48-16 thread/inch  
**G** 1.75-3.0mm or 14-8 thread/inch

MMT M-CLASS INSERTS WITH 3-D CHIP BREAKERS THREADING

## INTERNAL

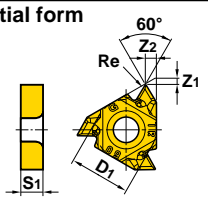
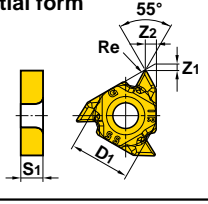
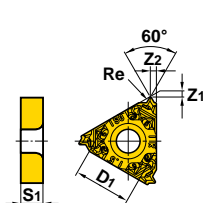
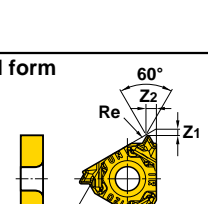
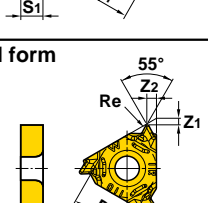
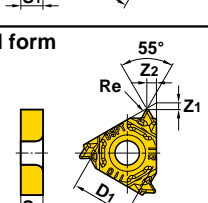
Type	Order Number	Coated	Pitch		Dimensions (mm)					Total Cutting Depth (mm)	Geometry
		VP15TF	mm	thread/inch	D1	S1	Z1	Z2	Re		
Partial Profile 60°	MMT11IRA60-S	●	0.5–1.5	48–16	6.35	3.04	0.8	0.9	0.03	—	Partial form 
	16IRA60-S	●	0.5–1.5	48–16	9.525	3.44	0.8	0.9	0.03	—	
	16IRG60-S	●	1.75–3.0	14–8	9.525	3.44	1.2	1.7	0.11	—	
Partial Profile 55°	MMT11IRA55-S	●		48–16	6.35	3.04	0.8	0.9	0.07	—	Partial form 
	16IRA55-S	●		48–16	9.525	3.44	0.8	0.9	0.07	—	
	16IRG55-S	●		14–8	9.525	3.44	1.2	1.7	0.21	—	
ISO Metric	MMT11IR100ISO-S	●	1.0		6.35	3.04	0.6	0.7	0.06	0.58	Full form 
	11IR125ISO-S	●	1.25		6.35	3.04	0.8	0.9	0.08	0.72	
	11IR150ISO-S	●	1.5		6.35	3.04	0.8	1.0	0.10	0.87	
	16IR100ISO-S	●	1.0		9.525	3.44	0.6	0.7	0.06	0.58	
	16IR125ISO-S	●	1.25		9.525	3.44	0.8	0.9	0.08	0.72	
	16IR150ISO-S	●	1.5		9.525	3.44	0.8	1.0	0.10	0.87	
	16IR175ISO-S	●	1.75		9.525	3.44	0.9	1.2	0.11	1.01	
	16IR200ISO-S	●	2.0		9.525	3.44	1.0	1.3	0.13	1.15	
	16IR250ISO-S	●	2.5		9.525	3.44	1.1	1.5	0.17	1.44	
	16IR300ISO-S	●	3.0		9.525	3.44	1.1	1.5	0.20	1.73	
American UN	MMT16IR160UN-S	●		16	9.525	3.44	0.9	1.1	0.11	0.92	Full form 
	16IR140UN-S	●		14	9.525	3.44	0.9	1.2	0.12	1.05	
	16IR120UN-S	●		12	9.525	3.44	1.1	1.4	0.14	1.22	
Whitworth for BSW, BSP	MMT16IR190W-S	●		19	9.525	3.44	0.8	1.0	0.18	0.86	Full form 
	16IR140W-S	●		14	9.525	3.44	1.0	1.2	0.25	1.16	
	16IR110W-S	●		11	9.525	3.44	1.1	1.5	0.32	1.48	
BSPT	MMT16IR190BSPT-S	●		19	9.525	3.44	0.8	0.9	0.18	0.86	Full form 
	16IR140BSPT-S	●		14	9.525	3.44	1.0	1.2	0.25	1.16	
	16IR110BSPT-S	●		11	9.525	3.44	1.1	1.5	0.32	1.48	

MMT M-CLASS INSERTS WITH 3-D CHIP BREAKERS 

# MMT G-CLASS GROUND INSERTS

MMT G-CLASS GROUND INSERTS | THREADING

## EXTERNAL

Type	Thread Tolerance	Order Number	Coated		Pitch		Dimensions (mm)					Total Cutting Depth (mm)	Geometry
			VP10MF	VP15TF	mm	thread/inch	D1	S1	Z1	Z2	Re		
Partial Profile 60°	—	<b>MMT16ERA60</b>	●	●	0.5–1.5	48–16	9.525	3.44	0.8	0.9	0.05	—	
		<b>16ERG60</b>	●	●	1.75–3.0	14–8	9.525	3.44	1.2	1.7	0.27	—	
		<b>16ERAG60</b>	●	●	0.5–3.0	48–8	9.525	3.44	1.2	1.7	0.08	—	
		<b>22ERN60</b>	●	●	3.5–5.0	7–5	12.7	4.64	1.7	2.5	0.53	—	
Partial Profile 55°	—	<b>MMT16ERA55</b>	●	●		48–16	9.525	3.44	0.8	0.9	0.05	—	
		<b>16ERG55</b>	●	●		14–8	9.525	3.44	1.2	1.7	0.21	—	
		<b>16ERAG55</b>	●	●		48–8	9.525	3.44	1.2	1.7	0.07	—	
		<b>22ERN55</b>	●	●		7–5	12.7	4.64	1.7	2.5	0.44	—	
ISO Metric 6g	—	<b>MMT16ER050ISO</b>	●	●	0.5		9.525	3.44	0.6	0.4	0.06	0.31	
		<b>16ER075ISO</b>	●	●	0.75		9.525	3.44	0.6	0.6	0.10	0.46	
		<b>16ER100ISO</b>	●	●	1.0		9.525	3.44	0.7	0.7	0.16	0.61	
		<b>16ER125ISO</b>	●	●	1.25		9.525	3.44	0.8	0.9	0.19	0.77	
		<b>16ER150ISO</b>	●	●	1.5		9.525	3.44	0.8	1.0	0.23	0.92	
		<b>16ER175ISO</b>	●	●	1.75		9.525	3.44	0.9	1.2	0.21	1.07	
		<b>16ER200ISO</b>	●	●	2.0		9.525	3.44	1.0	1.3	0.31	1.23	
		<b>16ER250ISO</b>	●	●	2.5		9.525	3.44	1.1	1.5	0.32	1.53	
		<b>16ER300ISO</b>	●	●	3.0		9.525	3.44	1.2	1.6	0.46	1.84	
		<b>22ER350ISO</b>	●	●	3.5		12.7	4.64	1.6	2.3	0.45	2.15	
		<b>22ER400ISO</b>	●	●	4.0		12.7	4.64	1.6	2.3	0.52	2.45	
		<b>22ER450ISO</b>	●	●	4.5		12.7	4.64	1.7	2.4	0.58	2.76	
<b>22ER500ISO</b>	●	●	5.0		12.7	4.64	1.7	2.5	0.63	3.07			

## IDENTIFICATION

<b>MMT</b>	<b>16</b>	<b>E</b>	<b>R</b>	<b>050</b>	<b>ISO</b>
<b>Designation</b>	<b>Diameter of Inscribed Circle (mm)</b>	<b>Application</b>	<b>Hand of Tool</b>	<b>Pitch</b>	<b>Threading Type</b>
	11 6.35	E External	R Right	050 0.5mm	60 Partial Profile 60°
	16 9.525	I Internal		075 0.75mm	55 Partial Profile 55°
	22 12.7			100 1.0mm	ISO ISO Metric
				125 1.25mm	W Whitworth for BSW, BSP
				150 1.5mm	BSPT BSPT
				175 1.75mm	UN American UN
				200 2.0mm	RD Round DIN 405
				250 2.5mm	TR ISO Trapezoidal 30°
				300 3.0mm	ACME American ACME
				350 3.5mm	UNJ UNJ
				400 4.0mm	APBU API Buttress Casing
				450 4.5mm	APRD API Round Casing & Tubing
				500 5.0mm	NPT NPT
					NPTF NPTF

● : Inventory maintained. (Note:- Inserts packed in 5 piece boxes)

## INTERNAL

Type	Thread Tolerance	Order Number	Coated		Pitch		Dimensions (mm)					Total Cutting Depth (mm)	Geometry
			VP10MF	VP15TF			D1	S1	Z1	Z2	Re		
					mm	thread/inch							
Partial Profile 60°	—	MMT11IRA60	●	●	0.5–1.5	48–16	6.35	3.04	0.8	0.9	0.05	—	Partial form 
		16IRA60	●	●	0.5–1.5	48–16	9.525	3.44	0.8	0.9	0.05	—	
		16IRG60	●	●	1.75–3.0	14–8	9.525	3.44	1.2	1.7	0.16	—	
		16IRAG60	●	●	0.5–3.0	48–8	9.525	3.44	1.2	1.7	0.05	—	
		22IRN60	●	●	3.5–5.0	7–5	12.7	4.64	1.7	2.5	0.30	—	
Partial Profile 55°	—	MMT11IRA55	●	●		48–16	6.35	3.04	0.8	0.9	0.05	—	Partial form 
		16IRA55	●	●		48–16	9.525	3.44	0.8	0.9	0.05	—	
		16IRG55	●	●		14–8	9.525	3.44	1.2	1.7	0.21	—	
		16IRAG55	●	●		48–8	9.525	3.44	1.2	1.7	0.07	—	
		22IRN55	●	●		7–5	12.7	4.64	1.7	2.5	0.44	—	
ISO Metric 6H	—	MMT11IR050ISO	●	●	0.5		6.35	3.04	0.6	0.4	0.03	0.29	Full form 
		11IR075ISO	●	●	0.75		6.35	3.04	0.6	0.6	0.04	0.43	
		11IR100ISO	●	●	1.0		6.35	3.04	0.6	0.7	0.10	0.58	
		11IR125ISO	●	●	1.25		6.35	3.04	0.8	0.9	0.12	0.72	
		11IR150ISO	●	●	1.5		6.35	3.04	0.8	1.0	0.14	0.87	
		11IR175ISO	●	●	1.75		6.35	3.04	0.9	1.1	0.10	1.01	
		11IR200ISO	●	●	2.0		6.35	3.04	0.9	1.1	0.18	1.15	
		16IR050ISO	●	●	0.5		9.525	3.44	0.6	0.4	0.03	0.29	
		16IR075ISO	●	●	0.75		9.525	3.44	0.6	0.6	0.04	0.43	
		16IR100ISO	●	●	1.0		9.525	3.44	0.6	0.7	0.10	0.58	
		16IR125ISO	●	●	1.25		9.525	3.44	0.8	0.9	0.12	0.72	
		16IR150ISO	●	●	1.5		9.525	3.44	0.8	1.0	0.14	0.87	
		16IR175ISO	●	●	1.75		9.525	3.44	0.9	1.2	0.10	1.01	
		16IR200ISO	●	●	2.0		9.525	3.44	1.0	1.3	0.18	1.15	
		16IR250ISO	●	●	2.5		9.525	3.44	1.1	1.5	0.15	1.44	
		16IR300ISO	●	●	3.0		9.525	3.44	1.1	1.5	0.26	1.73	
		22IR350ISO	●	●	3.5		12.7	4.64	1.6	2.3	0.22	2.02	
22IR400ISO	●	●	4.0		12.7	4.64	1.6	2.3	0.25	2.31			
22IR450ISO	●	●	4.5		12.7	4.64	1.6	2.4	0.28	2.60			
22IR500ISO	●	●	5.0		12.7	4.64	1.6	2.3	0.32	2.89			

# MMT G-CLASS GROUND INSERTS

## EXTERNAL

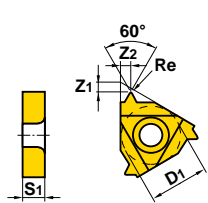
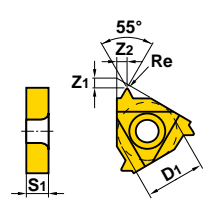
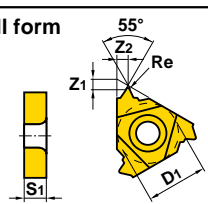
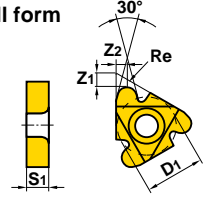
Type	Thread Tolerance	Order Number	Coated		Pitch		Dimensions (mm)					Total Cutting Depth (mm)	Geometry
			VP10MF	VP15TF	mm	thread/inch	D1	S1	Z1	Z2	Re		
American UN	2A	MMT16ER320UN	●			32	9.525	3.44	0.6	0.6	0.09	0.49	Full form 
		16ER280UN	●			28	9.525	3.44	0.6	0.7	0.10	0.56	
		16ER240UN	●			24	9.525	3.44	0.7	0.8	0.16	0.65	
		16ER200UN	●			20	9.525	3.44	0.8	0.9	0.19	0.78	
		16ER180UN	●			18	9.525	3.44	0.8	1.0	0.21	0.87	
		16ER160UN	●	●		16	9.525	3.44	0.9	1.1	0.24	0.97	
		16ER140UN	●	●		14	9.525	3.44	1.0	1.2	0.22	1.11	
		16ER130UN	●			13	9.525	3.44	1.0	1.3	0.24	1.20	
		16ER120UN	●	●		12	9.525	3.44	1.1	1.4	0.32	1.30	
		16ER110UN	●			11	9.525	3.44	1.1	1.5	0.29	1.42	
		16ER100UN	●			10	9.525	3.44	1.1	1.5	0.32	1.56	
		16ER090UN	●			9	9.525	3.44	1.2	1.7	0.35	1.73	
		16ER080UN	●			8	9.525	3.44	1.2	1.6	0.48	1.95	
		22ER070UN	●			7	12.7	4.64	1.6	2.3	0.47	2.22	
		22ER060UN	●			6	12.7	4.64	1.6	2.3	0.53	2.60	
22ER050UN	●			5	12.7	4.64	1.7	2.5	0.64	3.12			
Whitworth for BSW, BSP	Medium Class A	MMT16ER280W	●			28	9.525	3.44	0.6	0.7	0.09	0.58	Full form 
		16ER260W	●			26	9.525	3.44	0.7	0.8	0.10	0.63	
		16ER200W	●			20	9.525	3.44	0.8	0.9	0.18	0.81	
		16ER190W	●	●		19	9.525	3.44	0.8	1.0	0.19	0.86	
		16ER180W	●			18	9.525	3.44	0.8	1.0	0.20	0.90	
		16ER160W	●			16	9.525	3.44	0.9	1.1	0.23	1.02	
		16ER140W	●	●		14	9.525	3.44	1.0	1.2	0.26	1.16	
		16ER120W	●			12	9.525	3.44	1.1	1.4	0.30	1.36	
		16ER110W	●	●		11	9.525	3.44	1.1	1.5	0.33	1.48	
		16ER100W	●			10	9.525	3.44	1.1	1.5	0.37	1.63	
		16ER090W	●			9	9.525	3.44	1.2	1.7	0.34	1.81	
		16ER080W	●			8	9.525	3.44	1.2	1.5	0.39	2.03	
		22ER070W	●			7	12.7	4.64	1.6	2.3	0.46	2.32	
22ER060W	●			6	12.7	4.64	1.6	2.3	0.53	2.71			
22ER050W	●			5	12.7	4.64	1.7	2.4	0.66	3.25			
BSPT	Standard BSPT	MMT16ER280BSPT	●			28	9.525	3.44	0.6	0.6	0.09	0.58	Full form 
		16ER190BSPT	●	●		19	9.525	3.44	0.8	0.9	0.14	0.86	
		16ER140BSPT	●	●		14	9.525	3.44	1.0	1.2	0.26	1.16	
		16ER110BSPT	●	●		11	9.525	3.44	1.1	1.5	0.33	1.48	
Round DIN 405	7h	MMT16ER100RD	●			10	9.525	3.44	1.1	1.2	0.60	1.27	Full form 
		16ER080RD	●			8	9.525	3.44	1.4	1.3	0.75	1.59	
		16ER060RD	●			6	9.525	3.44	1.5	1.7	1.00	2.12	
		22ER040RD	●			4	9.525	3.44	2.2	2.3	1.51	3.18	

MMT G-CLASS GROUND INSERTS | THREADING

● : Inventory maintained. (Note:- Inserts packed in 5 piece boxes)

## INTERNAL

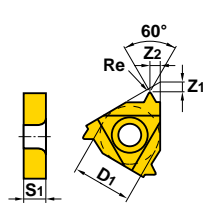
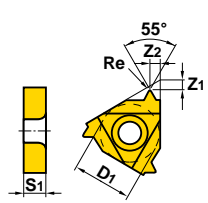
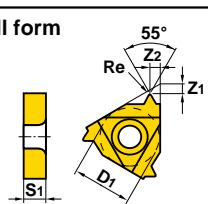
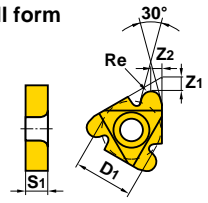
Type	Thread Tolerance	Order Number	Coated		Pitch		Dimensions (mm)					Total Cutting Depth (mm)	Geometry
			VP10MF	VP15TF	mm	thread/inch	D1	S1	Z1	Z2	Re		
American UN	2B	MMT11IR320UN	●			32	6.35	3.04	0.6	0.6	0.04	0.46	Full form 
		11IR280UN	●			28	6.35	3.04	0.6	0.7	0.05	0.52	
		11IR240UN	●			24	6.35	3.04	0.7	0.8	0.09	0.61	
		11IR200UN	●			20	6.35	3.04	0.8	0.9	0.11	0.73	
		11IR180UN	●			18	6.35	3.04	0.8	1.0	0.12	0.81	
		11IR160UN	●			16	6.35	3.04	0.9	1.1	0.14	0.92	
		11IR140UN	●			14	6.35	3.04	0.9	1.1	0.11	1.05	
		16IR320UN	●			32	9.525	3.44	0.6	0.6	0.04	0.46	
		16IR280UN	●			28	9.525	3.44	0.6	0.7	0.05	0.52	
		16IR240UN	●			24	9.525	3.44	0.7	0.8	0.09	0.61	
		16IR200UN	●			20	9.525	3.44	0.8	0.9	0.11	0.73	
		16IR180UN	●			18	9.525	3.44	0.8	1.0	0.12	0.81	
		16IR160UN	●●			16	9.525	3.44	0.9	1.1	0.14	0.92	
		16IR140UN	●●			14	9.525	3.44	0.9	1.2	0.11	1.05	
		16IR130UN	●●			13	9.525	3.44	1.0	1.3	0.10	1.13	
		16IR120UN	●●			12	9.525	3.44	1.1	1.4	0.18	1.22	
		16IR110UN	●			11	9.525	3.44	1.1	1.5	0.13	1.33	
		16IR100UN	●			10	9.525	3.44	1.1	1.5	0.15	1.47	
		16IR090UN	●			9	9.525	3.44	1.2	1.7	0.17	1.63	
		16IR080UN	●			8	9.525	3.44	1.1	1.5	0.27	1.83	
22IR070UN	●			7	12.7	4.64	1.6	2.3	0.23	2.09			
22IR060UN	●			6	12.7	4.64	1.6	2.3	0.26	2.44			
22IR050UN	●			5	12.7	4.64	1.6	2.3	0.32	2.93			
Whitworth for BSW, BSP	Medium Class A	MMT11IR190W	●			19	6.35	3.04	0.8	1.0	0.19	0.86	Full form 
		11IR140W	●			14	6.35	3.04	0.9	1.1	0.26	1.16	
		16IR280W	●			28	9.525	3.44	0.6	0.7	0.09	0.58	
		16IR260W	●			26	9.525	3.44	0.7	0.8	0.10	0.63	
		16IR200W	●			20	9.525	3.44	0.8	0.9	0.18	0.81	
		16IR190W	●●			19	9.525	3.44	0.8	1.0	0.19	0.86	
		16IR180W	●			18	9.525	3.44	0.8	1.0	0.20	0.90	
		16IR160W	●			16	9.525	3.44	0.9	1.1	0.23	1.02	
		16IR140W	●●			14	9.525	3.44	1.0	1.2	0.26	1.16	
		16IR120W	●			12	9.525	3.44	1.1	1.4	0.30	1.36	
		16IR110W	●●			11	9.525	3.44	1.1	1.5	0.33	1.48	
		16IR100W	●			10	9.525	3.44	1.1	1.5	0.37	1.63	
		16IR090W	●			9	9.525	3.44	1.2	1.7	0.34	1.81	
		16IR080W	●			8	9.525	3.44	1.2	1.5	0.39	2.03	
		22IR070W	●			7	12.7	4.64	1.6	2.3	0.46	2.32	
22IR060W	●			6	12.7	4.64	1.6	2.3	0.53	2.71			
22IR050W	●			5	12.7	4.64	1.7	2.4	0.66	3.25			
BSPT	Standard BSPT	MMT11IR190BSPT	●			19	6.35	3.04	0.8	0.9	0.14	0.86	Full form 
		11IR140BSPT	●			14	6.35	3.04	0.9	1.0	0.26	1.16	
		16IR190BSPT	●●			19	9.525	3.44	0.8	0.9	0.14	0.86	
		16IR140BSPT	●●			14	9.525	3.44	1.0	1.2	0.26	1.16	
		16IR110BSPT	●●			11	9.525	3.44	1.1	1.5	0.33	1.48	
Round DIN 405	7H	MMT16IR100RD	●			10	9.525	3.44	1.1	1.2	0.55	1.27	Full form 
		16IR080RD	●			8	9.525	3.44	1.4	1.4	0.70	1.59	
		16IR060RD	●			6	9.525	3.44	1.4	1.5	0.93	2.12	
		22IR040RD	●			4	12.7	4.64	2.2	2.3	1.40	3.18	

MMT G-CLASS GROUND INSERTS THREADING

# MMT G-CLASS GROUND INSERTS

## EXTERNAL

Type	Thread Tolerance	Order Number	Coated VP10MF	Pitch		Dimensions (mm)					Total Cutting Depth (mm)	Geometry
				mm	thread/inch	D1	S1	Z1	Z2	Re		
ISO Trapezoidal 30°	7e	MMT16ER150TR	●	1.5		9.525	3.44	1.0	1.1	0.08	0.90	Semi-full form 
		16ER200TR	●	2.0		9.525	3.44	1.1	1.3	0.15	1.25	
		16ER300TR	●	3.0		9.525	3.44	1.3	1.5	0.15	1.75	
		22ER400TR	●	4.0		12.7	4.64	1.7	1.9	0.15	2.25	
		22ER500TR	●	5.0		12.7	4.64	2.1	2.5	0.15	2.75	
American ACME	3G	MMT16ER120ACME	●		12	9.525	3.44	1.1	1.2	0.08	1.19	Semi-full form 
		16ER100ACME	●		10	9.525	3.44	1.3	1.4	0.08	1.52	
		16ER080ACME	●		8	9.525	3.44	1.4	1.5	0.10	1.84	
		22ER060ACME	●		6	12.7	4.64	1.8	2.1	0.10	2.37	
		22ER050ACME	●		5	12.7	4.64	2.0	2.3	0.10	2.79	
UNJ	3A	MMT16ER320UNJ	●		32	9.525	3.44	0.6	0.7	0.13	0.46	Full form 
		16ER280UNJ	●		28	9.525	3.44	0.7	0.7	0.14	0.52	
		16ER240UNJ	●		24	9.525	3.44	0.7	0.8	0.17	0.61	
		16ER200UNJ	●		20	9.525	3.44	0.8	0.9	0.20	0.73	
		16ER180UNJ	●		18	9.525	3.44	0.8	1.0	0.22	0.81	
		16ER160UNJ	●		16	9.525	3.44	0.9	1.1	0.25	0.92	
		16ER140UNJ	●		14	9.525	3.44	1.0	1.2	0.29	1.05	
		16ER120UNJ	●		12	9.525	3.44	1.1	1.3	0.33	1.22	
		16ER100UNJ	●		10	9.525	3.44	1.2	1.5	0.40	1.47	
		16ER080UNJ	●		8	9.525	3.44	1.2	1.6	0.51	1.83	
API Buttress Casing	Standard API	MMT22ER050APBU	●		5	12.7	4.64	3.1	1.9	0.18	1.55	Full form 
API Round Casing & Tubing	Standard API RD	MMT16ER100APRD	●		10	9.525	3.44	1.2	1.4	0.34	1.41	Full form 
		16ER080APRD	●		8	9.525	3.44	1.3	1.5	0.41	1.81	
American NPT	Standard NPT	MMT16ER270NPT	●		27	9.525	3.44	0.7	0.8	0.04	0.66	Full form 
		16ER180NPT	●		18	9.525	3.44	0.8	1.0	0.08	1.01	
		16ER140NPT	●		14	9.525	3.44	0.9	1.2	0.09	1.33	
		16ER115NPT	●		11.5	9.525	3.44	1.1	1.5	0.11	1.64	
		16ER080NPT	●		8	9.525	3.44	1.3	1.8	0.14	2.42	
American NPTF	Class 2	MMT16ER270NPTF	●		27	9.525	3.44	0.7	0.8	0.04	0.64	Full form 
		16ER180NPTF	●		18	9.525	3.44	0.8	1.0	0.04	1.00	
		16ER140NPTF	●		14	9.525	3.44	0.9	1.2	0.04	1.35	
		16ER115NPTF	●		11.5	9.525	3.44	1.1	1.5	0.04	1.63	
		16ER080NPTF	●		8	9.525	3.44	1.3	1.8	0.04	2.38	

MMT G-CLASS GROUND INSERTS | THREADING

● : Inventory maintained. (Note:- Inserts packed in 5 piece boxes)

## INTERNAL

Type	Thread Tolerance	Order Number	Coated		Dimensions (mm)					Total Cutting Depth (mm)	Geometry	
			VP10MF	Pitch		D1	S1	Z1	Z2			Re
				mm	thread/inch							
ISO Trapezoidal 30°	7H	MMT16IR150TR	●	1.5		9.525	3.44	1.0	1.1	0.08	0.90	
		16IR200TR	●	2.0		9.525	3.44	1.1	1.3	0.15	1.25	
		16IR300TR	●	3.0		9.525	3.44	1.3	1.5	0.15	1.75	
		22IR400TR	●	4.0		12.7	4.64	1.7	1.9	0.15	2.25	
		22IR500TR	●	5.0		12.7	4.64	2.1	2.5	0.15	2.75	
American ACME	3G	MMT16IR120ACME	●		12	9.525	3.44	1.2	1.3	0.05	1.19	
		16IR100ACME	●		10	9.525	3.44	1.2	1.3	0.08	1.52	
		16IR080ACME	●		8	9.525	3.44	1.4	1.5	0.10	1.84	
		22IR060ACME	●		6	12.7	4.64	1.8	2.1	0.10	2.37	
		22IR050ACME	●		5	12.7	4.64	2.0	2.3	0.10	2.79	
UNJ		When machining an internal UNJ thread, cut an internal hole with the appropriate diameter. Then machine with 60° American UN. In this case, a full form type insert cannot be used.										
API Buttress Casing	Standard API	MMT22IR050APBU	●		5	12.7	4.64	2.8	1.9	0.18	1.55	
API Round Casing & Tubing	Standard API RD	MMT16IR100APRD	●		10	9.525	3.44	1.2	1.4	0.34	1.41	
		16IR080APRD	●		8	9.525	3.44	1.3	1.5	0.41	1.81	
American NPT	Standard NPT	MMT16IR270NPT	●		27	9.525	3.44	0.7	0.8	0.04	0.66	
		16IR180NPT	●		18	9.525	3.44	0.8	1.0	0.08	1.01	
		16IR140NPT	●		14	9.525	3.44	0.9	1.2	0.09	1.33	
		16IR115NPT	●		11.5	9.525	3.44	1.1	1.5	0.11	1.64	
		16IR080NPT	●		8	9.525	3.44	1.3	1.8	0.14	2.42	
American NPTF	Class 2	MMT16IR140NPTF	●		14	9.525	3.44	0.9	1.2	0.04	1.35	
		16IR115NPTF	●		11.5	9.525	3.44	1.1	1.5	0.04	1.63	
		16IR080NPTF	●		8	9.525	3.44	1.3	1.8	0.04	2.38	

# EXTERNAL THREADING

## SET HOLDER

- Clamp-on type.
- Various insert types.
- Inserts with chip breaker give excellent chip control.
- Thread pitch  $\leq 3\text{mm}$ .

### SETH

#### External threading

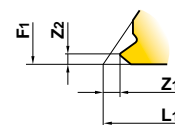
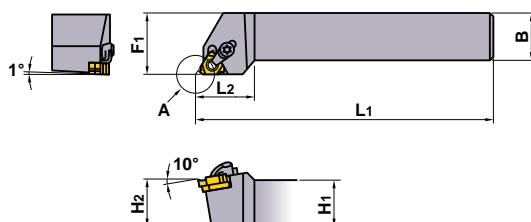
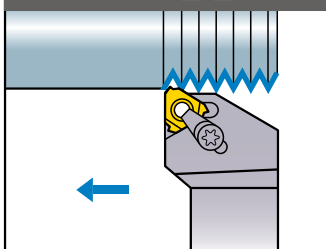

Details of position A  
(Refer to next page for size Z1, Z2.)

(Note) Cutting in the opposite direction is not possible.

Right hand tool holder only.

Order Number	Stock R	Insert Number	Dimensions (mm)							Clamp Bridge	Clamp Screw	Stop Ring	Shim Screw	Shim	Wrench
			H1	B	L1	L2	H2	F1							
SETHR1616H16	●	SET○○○○R3X○○	16	16	100	25	16	20	SETK51	SETS51	CR4	HFC03008	CT32T1	①TKY15F ②HKY20R	
2020K16	●		20	20	125	25	20	25	SETK51	SETS51	CR4	HFC03008	CT32T1	①TKY15F ②HKY20R	
2525M16	●		25	25	150	28	25	32	SETK51	SETS51	CR4	HFC03008	CT32T1	①TKY15F ②HKY20R	

SET HOLDER | THREADING

### STANDARD OF DEPTH OF CUT ● METRIC SCREW THREAD

- The chart on the right shows the cutting depths when machining external ISO metric screw threads.
- When using cermet grades or cutting stainless steel, please increase the number of passes by 2–3 times.

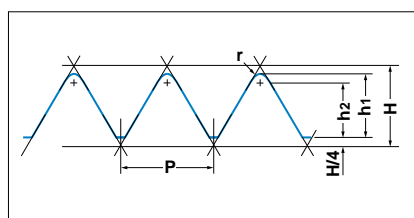

P (Pitch)	0.75	1.00	1.25	1.50	1.75	2.00	2.50	3.00	
h1	0.46	0.61	0.77	0.92	1.07	1.23	1.53	1.84	
h2	0.35	0.47	0.59	0.70	0.82	0.94	1.17	1.41	
r (Nose Radius)	0.11	0.14	0.18	0.22	0.25	0.29	0.36	0.43	
Number of Passes	1	0.18	0.20	0.20	0.25	0.25	0.25	0.30	0.30
	2	0.13	0.15	0.18	0.20	0.20	0.25	0.25	0.25
	3	0.10	0.10	0.12	0.15	0.20	0.20	0.20	0.25
	4	0.05	0.10	0.12	0.15	0.15	0.15	0.20	0.20
	5		0.06	0.10	0.10	0.12	0.15	0.15	0.20
	6			0.05	0.07	0.10	0.10	0.10	0.15
	7					0.05	0.08	0.10	0.15
	8						0.05	0.10	0.10
	9							0.08	0.10
	10							0.05	0.09
	11								0.05

(Note) The first pass causes a high load on the cutting edge.  
In order to avoid damage, keep the depth of cut to 0.4–0.5mm maximum.

### RECOMMENDED CUTTING CONDITIONS

Work Material	Hardness	Grade	Cutting Speed (m/min)
P Mild Steel	$\leq 180\text{HB}$	US735	120 (80–150)
		NX55	200 (150–250)
		UTi20T	120 (100–150)
Carbon Steel Alloy Steel	180–280HB	US735	100 (80–130)
		NX55	170 (150–200)
		UTi20T	100 (70–120)

Work Material	Hardness	Grade	Cutting Speed (m/min)
M Stainless Steel	$\leq 200\text{HB}$	US735	100 (70–130)
		UTi20T	100 (70–130)
K Cast Iron	Tensile Strength $\leq 350\text{N/mm}^2$	US735	100 (80–120)
		UTi20T	80 (60–100)

## INSERTS

Type	Order Number	Class	Coated			ISO Pitch mm (thread/inch)	Dimensions (mm)					Geometry
			US735	Cermet	Carbide		US735	NX55	UT120T	D1	S1	
Partial Profile 60°	SET6006R3XMM	M	●	●	●	Ⓐ 0.5—1.5(48—16)	9.525	3.65	0.7	0.9	0.06	
	6022R3XMM	M	●	●	●	Ⓒ 1.75—3.0(14—8)	9.525	3.65	1.2	1.6	0.22	
Partial Profile 55°	SET5507R3XMP	M	●	●	●	Ⓐ (48—16)	9.525	3.65	0.7	0.9	0.07	
	5525R3XMP	M	●	●	●	Ⓒ (14—8)	9.525	3.65	1.2	1.6	0.25	
ISO Metric	SET100R3XMM	M	●	●	●	1.0	9.525	3.65	0.7	0.9	0.13	
	125R3XMM	M	●	●	●	1.25	9.525	3.65	0.7	0.9	0.16	
	150R3XMM	M	●	●	●	1.5	9.525	3.65	0.7	0.9	0.20	
	175R3XMM	M	●	●	●	1.75	9.525	3.65	1.2	1.6	0.22	
	200R3XMM	M	●	●	●	2.0	9.525	3.65	1.2	1.6	0.25	
	250R3XMM	M	●	●	●	2.5	9.525	3.65	1.2	1.6	0.31	
Whitworth for BSW, BSP	SET190R3XMP	M	●	●	●	(19)	9.525	3.65	0.7	0.9	0.17	
	140R3XMP	M	●	●	●	(14)	9.525	3.65	1.2	1.6	0.25	
	120R3XMP	M	●	●	●	(12)	9.525	3.65	1.2	1.6	0.29	
	110R3XMP	M	●	●	●	(11)	9.525	3.65	1.2	1.6	0.3	
BSPT	SET190R3XMPT	M	●	●	★	(19)	9.525	3.65	0.7	0.9	0.16	
	140R3XMPT	M	●	●	★	(14)	9.525	3.65	1.2	1.6	0.25	
	110R3XMPT	M	●	●	★	(11)	9.525	3.65	1.2	1.6	0.32	
American UN	SET240R3XMUN	M	●	●	●	(24)	9.525	3.65	0.7	0.9	0.13	
	200R3XMUN	M	●	●	●	(20)	9.525	3.65	0.7	0.9	0.16	
	160R3XMUN	M	●	●	●	(16)	9.525	3.65	0.7	0.9	0.20	
	140R3XMUN	M	●	●	●	(14)	9.525	3.65	1.2	1.6	0.23	
	120R3XMUN	M	●	●	●	(12)	9.525	3.65	1.2	1.6	0.27	

Ⓐ Pitch = 0.5—1.5(mm), thread / inch = 48—16    Ⓒ Pitch = 1.75—3.0(mm), thread / inch = 14—8

# INTERNAL THREADING

## SNT TYPE BORING BARS

- Minimum cutting diameter 12mm.
- Screw-on / clamp-on type.
- Inserts with chip breaker give excellent chip control.
- Thread pitch 0.5—3mm.

### SNTF

#### Internal threading

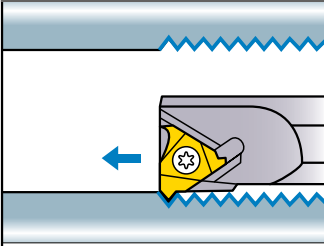

(Note) Cutting in the opposite direction is not possible.

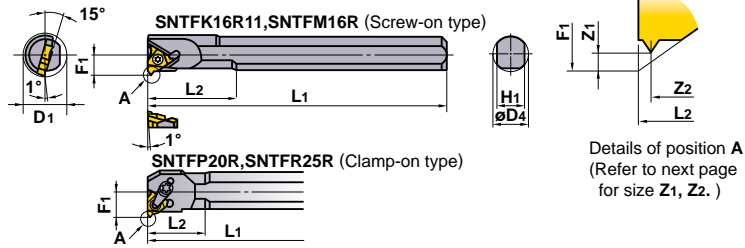

Right hand tool holder only.

Order Number	Thread Pitch mm (thread/inch)	Stock R	Insert Number	Dimensions (mm)					Min. Cutting Diameter D1	Tools						
				D4	L1	L2	F1	H1		Clamp Bridge	Clamp Screw	Stop Ring	Shim Screw	Shim	Wrench	
<b>SNTFK16R11</b>	0.5—1.5(48—16)	●	SNT○○○○R22○○	16	125	25	6.6	15	12	—	①TS25	—	—	—	—	①TKY08F
<b>M16R</b>	0.5—3.0(48—8)	●		16	150	40	10.6	14	19	—	①CS350 860T	—	—	—	—	①TKY15F
<b>P20R</b>	0.5—3.0(48—8)	●	SNT○○○○R3X○○	20	170	30	14.0	18	24	SETK51	②SETS51	CR4	HFC03008	CT32T1	①TKY15F ②HKY20R	
<b>R25R</b>	0.5—3.0(48—8)	●		25	200	38	16.5	23	29	SETK51	②SETS51	CR4	HFC03008	CT32T1	①TKY15F ②HKY20R	

SNT TYPE BORING BARS THREADING

### STANDARD OF DEPTH OF CUT ● METRIC SCREW THREAD

- The chart on the right shows the cutting depths when machining internal ISO metric screw threads.
- When using cermet grades or cutting stainless steel, please increase the number of passes by 2—3 times.

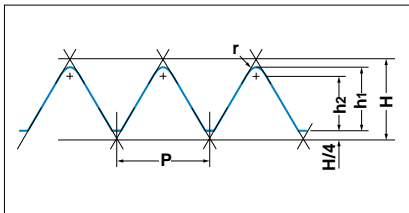

P (Pitch)	0.75	1.00	1.25	1.50	1.75	2.00	2.50	3.00
h1	0.43	0.58	0.72	0.87	1.01	1.15	1.44	1.73
h2	0.38	0.51	0.63	0.76	0.88	1.01	1.21	1.51
r (Nose Radius)	0.05	0.07	0.09	0.11	0.13	0.14	0.18	0.22
Number of Passes	1	0.10	0.15	0.18	0.20	0.23	0.25	0.25
	2	0.10	0.13	0.15	0.20	0.20	0.20	0.22
	3	0.10	0.10	0.12	0.15	0.20	0.15	0.20
	4	0.08	0.10	0.12	0.15	0.15	0.15	0.20
	5	0.05	0.05	0.10	0.10	0.10	0.15	0.15
	6		0.05	0.05	0.07	0.08	0.10	0.10
	7					0.05	0.10	0.10
	8						0.05	0.10
	9							0.07
	10							0.05
	11							

(Note) The first pass causes a high load on the cutting edge.  
In order to avoid damage, keep the depth of cut to 0.4—0.5mm maximum.

### RECOMMENDED CUTTING CONDITIONS

Work Material	Hardness	Grade	Cutting Speed (m/min)
P Mild Steel	≤180HB	US735	120 (80—150)
		NX55	200 (150—250)
		UTi20T	120 (100—150)
Carbon Steel Alloy Steel	180—280HB	US735	100 (80—130)
		NX55	170 (150—200)
		UTi20T	100 (70—120)

Work Material	Hardness	Grade	Cutting Speed (m/min)
M Stainless Steel	≤200HB	US735	100 (70—130)
		UTi20T	100 (70—130)
K Cast Iron	Tensile Strength ≤350N/mm <sup>2</sup>	US735	100 (80—120)
		UTi20T	80 (60—100)

- : Inventory maintained. ★ : Inventory maintained in Japan.
- ▲ : Inventory maintained. To be replaced by new products.

## INSERTS

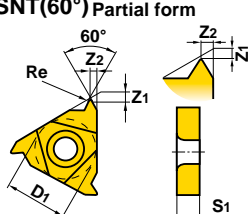
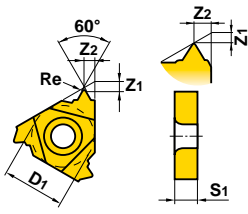
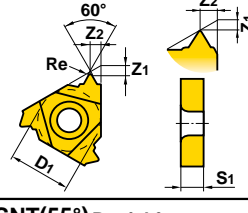
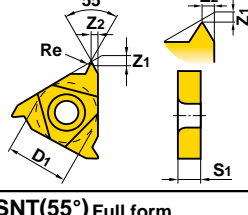
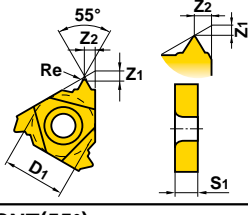
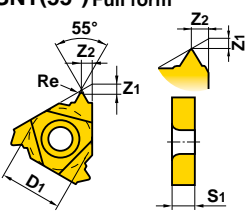
Type	Order Number	Class	Coated			ISO Pitch mm (thread/inch)	Dimensions (mm)					Geometry
			US735	Cermet	Carbide		D1	S1	Z1	Z2	Re	
Partial Profile 60°	SNT6004R22MM	M	●	▲	●	0.5—1.5(48—16)	6.35	3.18	0.7	0.9	0.04	<b>SNT(60°) Partial form</b> 
	6004R3XMM	M	●	▲	●	0.5—1.5(48—16)	9.525	3.65	0.7	0.9	0.04	
	6012R3XMM	M	●	▲	●	1.75—3.0(14—8)	9.525	3.65	1.2	1.6	0.12	
ISO Metric	SNT100R22MM	M		▲	●	1	6.35	3.18	0.7	0.9	0.07	<b>SNT(60°) Full form</b> 
	125R22MM	M		▲	●	1.25	6.35	3.18	0.7	0.9	0.09	
	150R22MM	M		▲	●	1.5	6.35	3.18	0.7	0.9	0.11	
	100R3XMM	M	●	▲	●	1	9.525	3.65	0.7	0.9	0.07	
	125R3XMM	M	●	▲	●	1.25	9.525	3.65	0.7	0.9	0.09	
	150R3XMM	M	●	▲	●	1.5	9.525	3.65	0.7	0.9	0.12	
	175R3XMM	M	●	▲	●	1.75	9.525	3.65	1.2	1.6	0.12	
	200R3XMM	M	●	▲	●	2	9.525	3.65	1.2	1.6	0.14	
	250R3XMM	M	●	▲	●	2.5	9.525	3.65	1.2	1.6	0.18	
300R3XMM	M	●	▲	●	3	9.525	3.65	1.2	1.6	0.21		
American UN	SNT240R3XMUN	M	●	▲	★	(24)	9.525	3.65	0.7	0.9	0.07	<b>SNT(60°) Full form</b> 
	200R3XMUN	M	●	▲	★	(20)	9.525	3.65	0.7	0.9	0.09	
	160R3XMUN	M	●	▲	★	(16)	9.525	3.65	0.7	0.9	0.11	
	140R3XMUN	M	●	▲	●	(14)	9.525	3.65	1.2	1.6	0.13	
	120R3XMUN	M	●	▲	★	(12)	9.525	3.65	1.2	1.6	0.15	
Partial Profile 55°	SNT5507R22MP	M	●	▲	●	(48—16)	6.35	3.18	0.7	0.8	0.07	<b>SNT(55°) Partial form</b> 
	5507R3XMP	M	●	▲	●	(48—16)	9.525	3.65	0.7	0.9	0.07	
	5525R3XMP	M	●	▲	●	(14—8)	9.525	3.65	1.2	1.6	0.25	
Whitworth for BSW, BSP	SNT190R3XMP	M	●	▲	●	(19)	9.525	3.65	0.7	0.8	0.17	<b>SNT(55°) Full form</b> 
	140R3XMP	M	●	▲	●	(14)	9.525	3.65	1.2	1.6	0.25	
	120R3XMP	M	●	▲	●	(12)	9.525	3.65	1.2	1.6	0.29	
	110R3XMP	M	●	▲	●	(11)	9.525	3.65	1.2	1.6	0.3	
BSPT	SNT190R3XMPT	M	●	★	★	(19)	9.525	3.65	0.7	0.9	0.18	<b>SNT(55°) Full form</b> 
	140R3XMPT	M	●	★	●	(14)	9.525	3.65	1.2	1.6	0.25	
	110R3XMPT	M	●	★	●	(11)	9.525	3.65	1.2	1.6	0.32	

# EXTERNAL THREADING

## MT HOLDER

- Clamp-on type.
- Positive insert suffers from negligible chattering and thus produces good finished surfaces.
- Thread pitch  $\leq 4.5\text{mm}$ .

### MTH

#### External threading

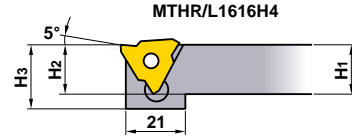
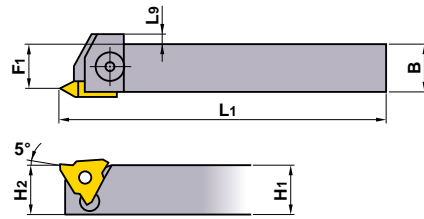
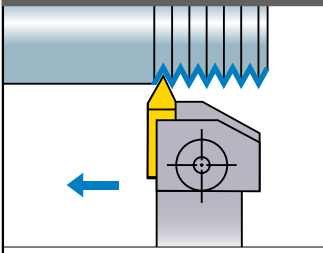

(Note) Cutting in the opposite direction is not possible.

Right hand tool holder shown.

Order Number	Stock		Insert Number	Dimensions (mm)						Clamp Bridge	Clamp Screw	Spring	Wrench	
	R	L		H1	B	L1	H2	H3	F1					L9
<b>MTHR/L1616H4</b>	★	★	MTTR/L43	16	16	100	16	19	13.8	3	MTK1R/L	HBH06020	MES3	HKY40R
<b>1616H22</b>	●			16	16	100	16	19	13.8	3	MTK1R	HBH06020	MES3	HKY40R
<b>2020K4</b>	●	★		20	20	125	20	—	17.8	—	MTK1R/L	HBH06020	MES3	HKY40R
<b>2020K22</b>	●			20	20	125	20	—	17.8	—	MTK1R	HBH06020	MES3	HKY40R
<b>2525M4</b>	●	★		25	25	150	25	—	22.8	—	MTK1R/L	HBH06020	MES3	HKY40R

MT HOLDER | THREADING

### MT1

#### External threading

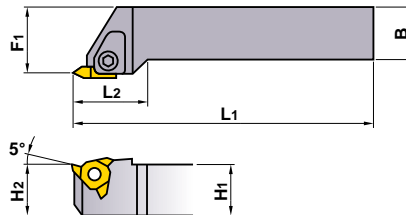
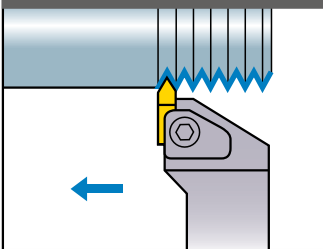

(Note) Cutting in the opposite direction is not possible.

Right hand tool holder shown.

Order Number	Stock		Insert Number	Dimensions (mm)						Clamp Bridge	Clamp Screw	Spring	Wrench
	R	L		H1	B	L1	L2	H2	F1				
<b>MT1R/L2020K4</b>	★	★	MTTR/L43	20	20	125	30	20	25	MTK1R/L	HBH06020	MES3	HKY40R
<b>2525M4</b>	★	★		25	25	150	30	25	32	MTK1R/L	HBH06020	MES3	HKY40R
<b>3232P4</b>	★	★		32	32	170	30	32	40	MTK1R/L	HBH06020	MES3	HKY40R

## RECOMMENDED CUTTING CONDITIONS

Work Material	Hardness	Grade	Cutting Speed (m/min)
P Mild Steel	$\leq 180\text{HB}$	UP20M	140 (100–180)
		NX55	200 (150–250)
		UTi20T	120 (100–150)
Carbon Steel Alloy Steel	180–280HB	UP20M	120 (100–150)
		NX55	170 (150–200)
		UTi20T	100 (70–120)

Work Material	Hardness	Grade	Cutting Speed (m/min)
M Stainless Steel	$\leq 200\text{HB}$	UP20M	120 (80–150)
		UTi20T	100 (70–130)
K Cast Iron	Tensile Strength $\leq 350\text{N/mm}^2$	UP20M	80 (60–100)
		UTi20T	80 (60–100)
		HTi10	100 (70–130)

## INSERTS

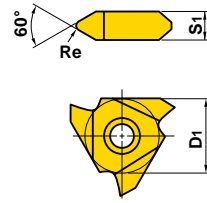
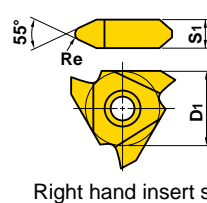
Type	Order Number	Class	Coated		Cermet		Carbide		ISO Pitch mm (thread/inch)	Dimensions (mm)			Geometry
			UP20M	NX55	UT120T	HT110	D1	S1		Re			
Partial Profile 60°	<b>MTTR436000</b>	G	□	★	●	□		-0.8	12.7	4.76	0	<b>MTTR/L(60°) Partial form</b>  Right hand insert shown.	
	<b>L436000</b>	G	□	★	●	□		-0.8	12.7	4.76	0		
	<b>R436001</b>	G	★	★	●	★		1.0-1.75	12.7	4.76	0.1		
	<b>L436001</b>	G	□	★	●	★		1.0-1.75	12.7	4.76	0.1		
	<b>R436002</b>	G	★	★	●	★		2.0-2.5	12.7	4.76	0.2		
	<b>L436002</b>	G	□	★	●	★		2.0-2.5	12.7	4.76	0.2		
	<b>R436003</b>	G	□	★	●	★		3.0-3.5	12.7	4.76	0.3		
	<b>L436003</b>	G	□	★	●	□		3.0-3.5	12.7	4.76	0.3		
	<b>R436004</b>	G	□	★	●	□		4.0-4.5	12.7	4.76	0.4		
<b>L436004</b>	G	□	★	★	□		4.0-4.5	12.7	4.76	0.4			
Partial Profile 55°	<b>MTTR435501</b>	G	□	★	●	□		(28-10)	12.7	4.76	0.1	<b>MTTR/L(55°) Partial form</b>  Right hand insert shown.	
	<b>L435501</b>	G	□	★	●	□		(28-10)	12.7	4.76	0.1		
	<b>R435502</b>	G	□	★	●	□		(16-8)	12.7	4.76	0.2		
	<b>L435502</b>	G	□	★	●	□		(16-8)	12.7	4.76	0.2		
	<b>R435503</b>	G	□	★	●	□		(11-8)	12.7	4.76	0.3		
	<b>L435503</b>	G	□	□	□	□		(11-8)	12.7	4.76	0.3		

### STANDARD OF DEPTH OF CUT

- The chart on the right shows the cutting depths when machining external ISO metric screw threads.
- When using cermet grades or cutting stainless steel, please increase the number of passes by 2-3 times.

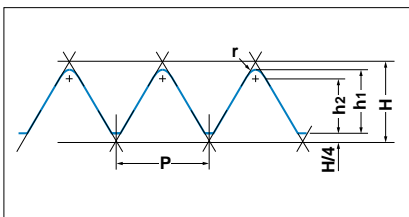

### METRIC SCREW THREAD

P (Pitch)	0.75	1.00	1.25	1.50	1.75	2.00	2.50	3.00	3.50	4.00	4.50	
<b>h1</b>	0.46	0.61	0.77	0.92	1.07	1.23	1.53	1.84	2.15	2.45	2.76	
<b>h2</b>	0.35	0.47	0.59	0.70	0.82	0.94	1.17	1.41	1.65	1.87	2.11	
<b>r (Nose Radius)</b>	0.11	0.14	0.18	0.22	0.25	0.29	0.36	0.43	0.50	0.58	0.65	
Number of Passes	<b>1</b>	0.18	0.20	0.20	0.25	0.25	0.25	0.30	0.30	0.35	0.35	0.40
	<b>2</b>	0.13	0.15	0.18	0.20	0.20	0.25	0.25	0.25	0.30	0.30	0.35
	<b>3</b>	0.10	0.10	0.12	0.15	0.20	0.20	0.20	0.25	0.25	0.25	0.30
	<b>4</b>	0.05	0.10	0.12	0.15	0.15	0.15	0.20	0.20	0.20	0.25	0.25
	<b>5</b>		0.06	0.10	0.10	0.12	0.15	0.15	0.20	0.20	0.25	0.25
	<b>6</b>			0.05	0.07	0.10	0.10	0.10	0.15	0.20	0.20	0.20
	<b>7</b>					0.05	0.08	0.10	0.15	0.15	0.20	0.20
	<b>8</b>						0.05	0.10	0.10	0.15	0.15	0.15
	<b>9</b>							0.08	0.10	0.10	0.15	0.15
	<b>10</b>								0.05	0.09	0.10	0.15
	<b>11</b>									0.05	0.10	0.15
	<b>12</b>										0.10	0.10
	<b>13</b>											0.10
	<b>14</b>											

(Note) The first pass causes a high load on the cutting edge.  
In order to avoid damage, keep the depth of cut to 0.4-0.5mm maximum.

# EXTERNAL THREADING

## SMG HOLDER

- Screw-on type.
- Positive insert suffers from negligible chattering.
- Suitable for narrow grooving and threading.
- Thread pitch  $\leq 2.0\text{mm}$ .

### SMGH

#### External threading, Grooving

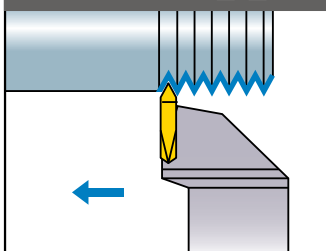

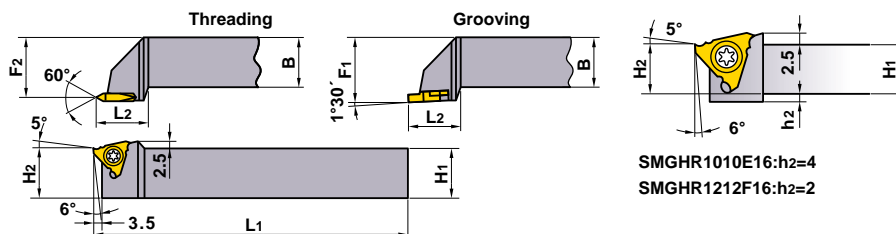

(Note) Cutting in the opposite direction is not possible.



SMGHR1010E16:h2=4  
SMGHR1212F16:h2=2

Right hand tool holder only.

Order Number	Stock	Insert Number		Dimensions (mm)									
		Threading	Grooving	H1	B	L1	L2	H2	F1	F2	Clamp Screw		
<b>SMGHR1010E16</b>	★	SMTTR160360	SMGTR16X2 SMGTR16X2C	10	10	70	16.5	10	12	11.7	FC400890T	TKY10F	
<b>1212F16</b>	★			12	12	80	16.5	12	16	15.7	FC400890T	TKY10F	
<b>1616H16</b>	★			16	16	100	20	16	20	19.7	FC400890T	TKY10F	
<b>2020K16</b>	★			20	20	125	20	20	25	24.7	FC400890T	TKY10F	
<b>2525M16</b>	★			25	25	150	20	25	32	31.7	FC400890T	TKY10F	

SMG HOLDER | THREADING

### STANDARD OF DEPTH OF CUT ● METRIC SCREW THREAD

- The chart on the right shows the cutting depths when machining external ISO metric screw threads.
- When using cermet grades or cutting stainless steel, please increase the number of passes by 2–3 times.

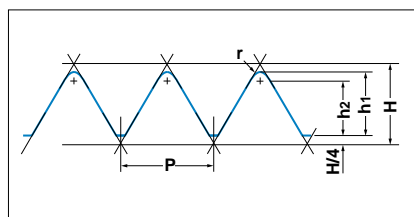

P (Pitch)		0.75	1.00	1.25	1.50	1.75	2.00
h1		0.46	0.61	0.77	0.92	1.07	1.23
h2		0.35	0.47	0.59	0.70	0.82	0.94
r (Nose Radius)		0.11	0.14	0.18	0.22	0.25	0.29
Number of Passes	1	0.18	0.20	0.20	0.25	0.25	0.25
	2	0.13	0.15	0.18	0.20	0.20	0.25
	3	0.10	0.10	0.12	0.15	0.20	0.20
	4	0.05	0.10	0.12	0.15	0.15	0.15
	5		0.06	0.10	0.10	0.12	0.15
	6			0.05	0.07	0.10	0.10
	7					0.05	0.08
	8						0.05
	9						

(Note) The first pass causes a high load on the cutting edge. In order to avoid damage, keep the depth of cut to 0.4–0.5mm maximum.

### RECOMMENDED CUTTING CONDITIONS

Work Material	Hardness	Grade	Cutting Speed (m/min)
<b>P</b> Mild Steel	$\leq 180\text{HB}$	<b>NX55</b>	200 (150–250)
		<b>UTi20T</b>	120 (100–150)
Carbon Steel Alloy Steel	180–280HB	<b>NX55</b>	170 (150–200)
		<b>UTi20T</b>	100 (70–120)

Work Material	Hardness	Grade	Cutting Speed (m/min)
<b>M</b> Stainless Steel	$\leq 200\text{HB}$	<b>UTi20T</b>	100 (70–130)
<b>K</b> Cast Iron	Tensile Strength $\leq 350\text{N/mm}^2$	<b>UTi20T</b>	80 (60–100)
		<b>HTi10</b>	100 (70–130)

★ : Inventory maintained in Japan. □ : Non stock, produced to order only.

## SMT INSERTS (Threading)

Order Number	Stock		Thread Pitch (mm)	Dimensions (mm)	Geometry
	Cermet	Carbide		Re	
	NX55	UT120T			
<b>SMTTR160360V5</b>	★	★	-0.8	0.05	
<b>16036001</b>	★	★	1.0-1.5	0.1	
<b>16036002</b>	★	★	1.75-2.0	0.2	

(Note) Wet cutting is recommended.

## SMG INSERTS (Grooving)

Order Number	Stock			Groove Width W <sub>3</sub>	Dimensions (mm)				Geometry
	Cermet		Carbide		L <sub>3</sub>	D <sub>1</sub>	S <sub>1</sub>	C	
	NX2525	UT120T	HT110						
<b>SMGTR16X2030</b>	★	★	★	0.3	1.0	9.525	2.0	-	
<b>16X2040</b>	□	□	□	0.4	1.0	9.525	2.0	-	
<b>16X2050</b>	★	★	★	0.5	1.5	9.525	2.0	-	
<b>16X2060</b>	□	□	□	0.6	1.5	9.525	2.0	-	
<b>16X2070</b>	★	★	★	0.7	2.0	9.525	2.0	-	
<b>16X2050C</b>	★	★	★	0.5	1.5	9.525	2.0	0.05	
<b>16X2060C</b>	□	□	□	0.6	1.5	9.525	2.0	0.05	
<b>16X2070C</b>	□	□	□	0.7	2.0	9.525	2.0	0.05	
<b>16X2075C</b>	★	★	★	0.75	2.0	9.525	2.0	0.05	
<b>16X2080C</b>	★	★	★	0.8	2.0	9.525	2.0	0.1	
<b>16X2090C</b>	□	□	□	0.9	2.0	9.525	2.0	0.1	
<b>16X2095C</b>	★	★	★	0.95	2.0	9.525	2.0	0.1	
<b>16X2100C</b>	★	★	★	1.0	2.5	9.525	2.0	0.1	
<b>16X2110C</b>	□	□	□	1.1	2.5	9.525	2.0	0.1	
<b>16X2120C</b>	★	★	★	1.2	2.5	9.525	2.0	0.1	
<b>16X2130C</b>	□	□	□	1.3	2.5	9.525	2.0	0.1	

THREADING

SMG HOLDER

# MICRO-MINI TWIN

## CT STANDARD

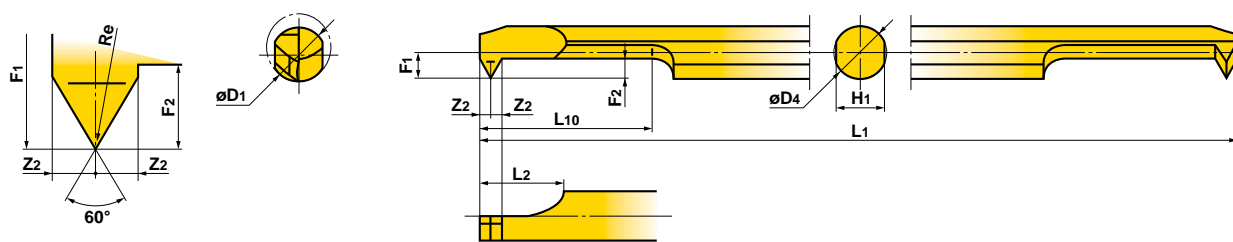

Order Number	Stock		Breaker	Threads				Min. Cutting Diameter D1	Dimensions (mm)								
	Micro Grain Carbide TF15	Coated VP15TF		Metric Screw		Unified Coarse Screw			Re	D4	L1	L10	L2	F1	Z2	F2	H1
				Thread	Pitch (mm)	Thread	Pitch (thread/inch)										
<b>CT03RS-M4</b>	●	●	Without	≥M4	0.5-1.0	≥NO.8-32UNC	36-24	<b>3</b>	0.03	3	50	10.2	6	1.3	0.6	1.2	2.7
<b>03RS-M4B</b>	●	●	With	≥M4	0.5-1.0	≥NO.8-36UNF	36-24	<b>3</b>	0.03	3	50	10.2	6	1.3	0.6	1.2	2.7
<b>04RS-M6</b>	●	●	Without	≥M6	0.75-1.25	≥1/4-20UNC	28-20	<b>4.5</b>	0.05	4	60	15.6	7	1.8	0.8	1.7	3.6
<b>04RS-M6B</b>	●	●	With	≥M6	0.75-1.25	≥1/4-28UNF	28-20	<b>4.5</b>	0.05	4	60	15.6	7	1.8	0.8	1.7	3.6
<b>05RS-M8</b>	●	●	Without	≥M8	0.75-1.5	≥5/16-18UNC	24-18	<b>6</b>	0.05	5	70	21	8	2.3	1	2.2	4.5
<b>05RS-M8B</b>	●	●	With	≥M8	0.75-1.5	≥5/16-24UNF	24-18	<b>6</b>	0.05	5	70	21	8	2.3	1	2.2	4.5
<b>06RS-M10</b>	●	●	Without	≥M10	0.75-1.75	≥3/8-16UNC	24-16	<b>7</b>	0.05	6	75	21	8	2.8	1	2.2	5.4
<b>06RS-M10B</b>	●	●	With	≥M10	0.75-1.75	≥3/8-24UNF	24-16	<b>7</b>	0.05	6	75	21	8	2.8	1	2.2	5.4

## RECOMMENDED CUTTING CONDITIONS

	Work Material	Cutting Speed (m/min)	Recommended Tool Overhang (mm)
<b>P</b>	General Steel	50 (30-80)	
<b>M</b>	Stainless Steel	50 (30-80)	
<b>K</b>	Cast Iron	50 (30-80)	
<b>N</b>	Non-Ferrous Metal	80 (50-100)	

(Note 1) Wet cutting is recommended.  
 (Note 2) Pay special attention to machining of small diameters at high revolution rates as the feed rate cannot keep up with the speed.

## PRECAUTIONS WHEN USING THE MICRO-MINI TWIN

● When using a holder for general purpose / small automatic lathe:

① To avoid chipping of the 2nd cutting edge take care when inserting the boring bar into the holder. Refer to fig.1. If the 2nd edge contacts the internal face of the holder there is a possibility that it may chip.

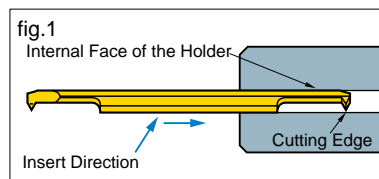

② When using this type of holder, there is a possibility that damage to the shank and the 2nd cutting edge can occur. Make sure that the clamping screws are tightened to the set torque value. Additionally make sure that there is no clamping screw near the 2nd cutting edge as this can break the boring bar.

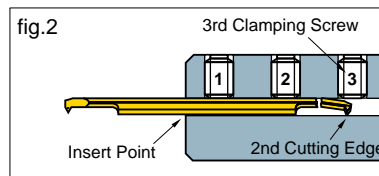

◎ When using Mitsubishi holders

When using holders with a tool overhang of recommended quantity, ensure that the 3rd clamping screw is removed prior to machining. The set torque value for clamping screw is 2.0 N•m.

● When using a square type holder:

① When installing the boring bar into the holder, tighten the clamp screws after ensuring the flats on the tool holder are parallel to the reference flats on the micro-mini bar. Refer to fig.3.

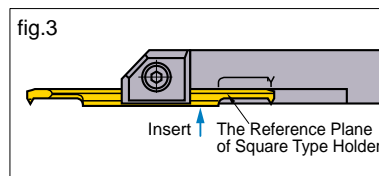

② Make sure that the clamping screws are tightened to the recommended values.

③ Do not tighten the clamp screw without a bar in place, otherwise the bridge will be deformed.

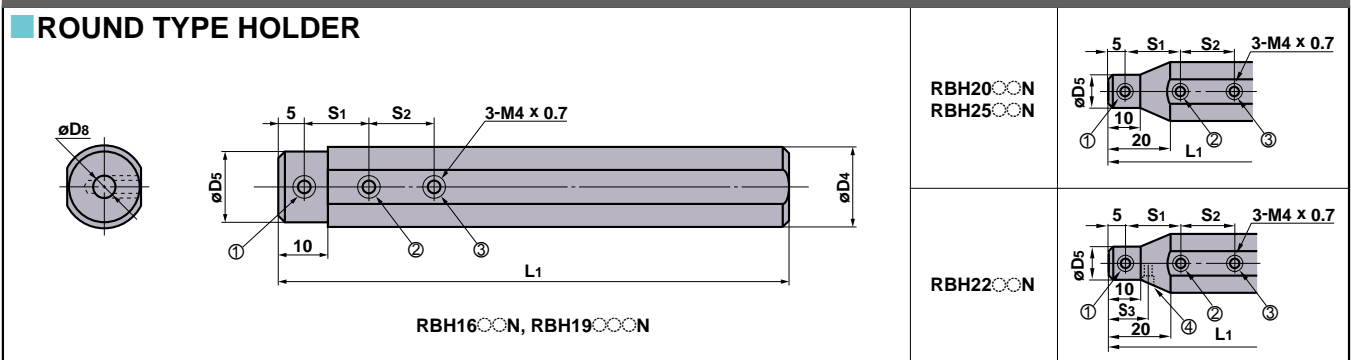

Order Number	Stock	Dimensions (mm)							Micro-Mini C	Micro-Mini Twin CT	★Clamp Screw				Wrench	Torque (N•m)
		D4	D8	D5	L1	S1	S2	S3			①	②	③	④		
RBH1630N	●	16	3	15	100	10	10	—	03FR-BLS	03RS-M4, 03RS-M4B	A	A	A	—	HKY20F	2.0
1640N	●	16	4	15	100	15	15	—	04FR-BLS	04RS-M6, 04RS-M6B	A	A	A	—	HKY20F	2.0
1650N	●	16	5	15	100	15	15	—	05HR-BLS	05RS-M8, 05RS-M8B	A	A	A	—	HKY20F	2.0
1660N	●	16	6	15	100	20	20	—	—	06RS-M10, 06RS-M10B	A	A	A	—	HKY20F	2.0
RBH19030N	●	19.05	3	18	125	10	10	—	03FR-BLS	03RS-M4, 03RS-M4B	B	B	B	—	HKY20F	2.0
19040N	●	19.05	4	18	125	15	15	—	04FR-BLS	04RS-M6, 04RS-M6B	B	B	B	—	HKY20F	2.0
19050N	●	19.05	5	18	125	15	15	—	05HR-BLS	05RS-M8, 05RS-M8B	B	B	B	—	HKY20F	2.0
19060N	●	19.05	6	18	125	20	20	—	—	06RS-M10, 06RS-M10B	B	B	B	—	HKY20F	2.0
RBH2030N	★	20	3	12	125	10	10	—	03FR-BLS	03RS-M4, 03RS-M4B	A	A	B	—	HKY20F	2.0
2040N	★	20	4	13	125	15	15	—	04FR-BLS	04RS-M6, 04RS-M6B	A	B	B	—	HKY20F	2.0
2050N	★	20	5	14	125	15	15	—	05HR-BLS	05RS-M8, 05RS-M8B	A	B	B	—	HKY20F	2.0
2060N	★	20	6	15	125	20	20	—	—	06RS-M10, 06RS-M10B	A	B	B	—	HKY20F	2.0
RBH2230N	★	22	3	12	125	10	10	10	03FR-BLS	03RS-M4, 03RS-M4B	A	B	C	A	HKY20F	2.0
2240N	★	22	4	13	125	15	15	12.5	04FR-BLS	04RS-M6, 04RS-M6B	A	B	B	A	HKY20F	2.0
2250N	★	22	5	14	125	15	15	12.5	05HR-BLS	05RS-M8, 05RS-M8B	A	B	B	A	HKY20F	2.0
2260N	★	22	6	15	125	20	20	15	—	06RS-M10, 06RS-M10B	A	B	B	A	HKY20F	2.0
RBH2530N	★	25	3	12	150	10	10	—	03FR-BLS	03RS-M4, 03RS-M4B	A	B	C	—	HKY20F	2.0
2540N	★	25	4	13	150	15	15	—	04FR-BLS	04RS-M6, 04RS-M6B	A	C	C	—	HKY20F	2.0
2550N	★	25	5	14	150	15	15	—	05HR-BLS	05RS-M8, 05RS-M8B	A	C	C	—	HKY20F	2.0
2560N	★	25	6	15	150	20	20	—	—	06RS-M10, 06RS-M10B	A	C	C	—	HKY20F	2.0

\* Order number of clamp screw A=HSS04004, B=HSS04006, C=HSS04008

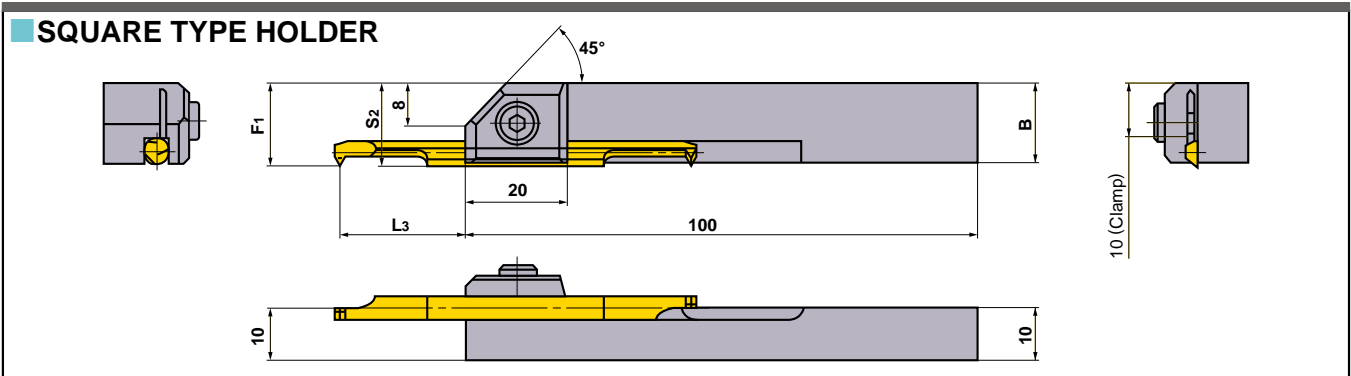

Order Number	Stock	Dimensions (mm)				Micro-Mini Twin CT	Clamp Screw	Wrench	Torque (N•m)
		B	F1	L3 *	S2				
SBH1030R	★	13.8	13.8	13—17.5(14)	14	03RS-M4, 03RS-M4B	HSC05012	HKY40R	9.5
1040R	★	14.7	14.8	18.5—22(19.5)	15	04RS-M6, 04RS-M6B	HSC05012	HKY40R	9.5
1050R	★	15.6	15.8	24—26.5(25)	16	05RS-M8, 05RS-M8B	HSC05012	HKY40R	9.5
1060R	★	16.5	16.8	24—31.5(25)	17	06RS-M10, 06RS-M10B	HSC05012	HKY40R	9.5

\* L3 is the length of overhang for capacity of clamping, and ( ) is the recommended length for general purpose steel machining.

# INTERNAL THREADING

## F TYPE BORING BARS

- Minimum cutting diameter 10mm.
- Screw-on type.
- Applicable to threading, grooving and boring.
- Thread pitch 1.5–3.5mm.

### FSL51

#### Internal threading, Grooving, Boring

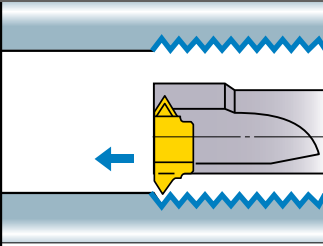

1 Corner Type  
(FSL5108R, 5110R)

2 Corner Type  
(FSL5112R, 5114R, 5116R)

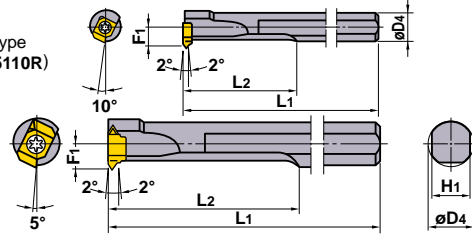

(Note) Cutting in the opposite direction is not possible.

Right hand tool holder only.

Order Number	Stock R	Insert Number			Dimensions (mm)					Min. Cutting Diameter	Clamp Screw	Wrench
		Threading	Grooving	Boring	D4	L1	L2	F1	H1			
<b>FSL5108R</b>	●	MLT1001L	MLG10 $\odot$ L	MLP1004L	8	125	30	4.8	7	<b>10</b>	TS25	TKY08F
<b>5110R</b>	●	MLT1001L	MLG10 $\odot$ L	MLP1004L	10	150	40	5.8	9	<b>12</b>	TS25	TKY08F
<b>5112R</b>	●	MLT1401L	MLG14 $\odot$ L	MLP1404L	12	180	50	6.8	10.8	<b>14</b>	TS32	TKY08F
<b>5114R</b>	●	MLT1401L	MLG14 $\odot$ L	MLP1404L	14	180	60	7.8	12.4	<b>16</b>	TS32	TKY08F
<b>5116R</b>	●	MLT2001L	MLG20 $\odot$ L	MLP2004L	16	200	70	9.7	14	<b>20</b>	TS43	TKY15F

F TYPE BORING BARS | THREADING

### FSL52

#### Carbide shank

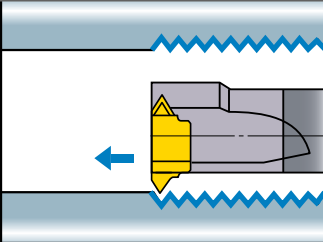

1 Corner Type  
(FSL5208R, 5210R)

2 Corner Type  
(FSL5212R, 5214R, 5216R)



(Note) Cutting in the opposite direction is not possible.

Right hand tool holder only.

Order Number	Stock R	Insert Number			Dimensions (mm)					Min. Cutting Diameter	Clamp Screw	Wrench
		Threading	Grooving	Boring	D4	L1	L2	F1	H1			
<b>FSL5208R</b>	●	MLT1001L	MLG10 $\odot$ L	MLP1004L	8	125	60	4.8	7	<b>10</b>	TS25	TKY08F
<b>5210R</b>	●	MLT1001L	MLG10 $\odot$ L	MLP1004L	10	150	70	5.8	9	<b>12</b>	TS25	TKY08F
<b>5212R</b>	●	MLT1401L	MLG14 $\odot$ L	MLP1404L	12	180	80	6.8	11	<b>14</b>	TS32	TKY08F
<b>5214R</b>	●	MLT1401L	MLG14 $\odot$ L	MLP1404L	14	180	85	7.8	12	<b>16</b>	TS32	TKY08F
<b>5216R</b>	●	MLT2001L	MLG20 $\odot$ L	MLP2004L	16	200	115	9.7	14	<b>20</b>	TS43	TKY15F

### RECOMMENDED CUTTING CONDITIONS

Work Material	Hardness	Grade	Cutting Speed (m/min)
<b>P</b> Mild Steel	≤180HB	UP20M	140 (100–180)
		UTi20T	120 (100–150)
Carbon Steel Alloy Steel	180–280HB	UP20M	120 (100–150)
		UTi20T	100 (70–120)

Work Material	Hardness	Grade	Cutting Speed (m/min)
<b>M</b> Stainless Steel	≤200HB	UP20M	120 (80–150)
		UTi20T	100 (70–130)
<b>K</b> Cast Iron	Tensile Strength ≤350N/mm <sup>2</sup>	UP20M	80 (60–100)
		UTi20T	80 (60–100)

- : Inventory maintained. ★ : Inventory maintained in Japan.
- : Non stock, produced to order only.

## INSERTS

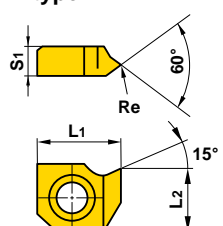
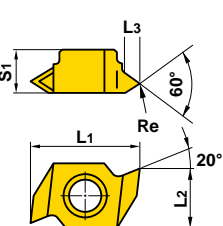
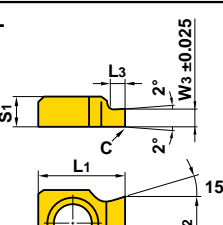
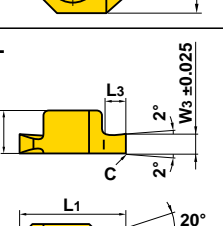
Application	Order Number	Coated		Thread Pitch, Groove Width W <sub>3</sub> (mm)	Dimensions (mm)						Geometry
		UP20M	UTi20T		L1	L2	L3	S1	C	Re	
Threading	<b>MLT1001L</b>	★	★	Pitch 1.5–2.0	7	5	–	2.38	–	0.1	<b>MLT•MLP type</b> 
	<b>1401L</b>	★	★	Pitch 1.5–2.5	11.8	6.5	–	4.76	–	0.1	
	<b>2001L</b>	★	★	Pitch 1.5–3.5	16.8	9.03	–	6.35	–	0.1	
Boring	<b>MLP1004L</b>		★	–	7	5	1.0	2.38	–	0.4	
	<b>1404L</b>		★	–	11.8	6.5	2.0	4.76	–	0.4	
	<b>2004L</b>		★	–	16.8	9.03	3.0	6.35	–	0.4	
Grooving	<b>MLG1012L</b>	□	●	1.2	7	5	1.0	2.38	0.1	–	<b>MLG...L</b> 
	<b>1015L</b>	□	●	1.5	7	5	1.0	2.38	0.1	–	
	<b>1020L</b>	□	●	2	7	5	1.0	2.38	0.1	–	
	<b>MLG1415L</b>		●	1.5	11.8	6.5	2.0	4.76	0.1	–	<b>MLG...L</b> 
	<b>1420L</b>		●	2	11.8	6.5	2.0	4.76	0.1	–	
	<b>1430L</b>		●	3	11.8	6.5	2.0	4.76	0.1	–	
	<b>2020L</b>		●	2	16.8	9.03	3.0	6.35	0.1	–	
	<b>2030L</b>		●	3	16.8	9.03	3.0	6.35	0.1	–	
	<b>2040L</b>		●	4	16.8	9.03	3.0	6.35	0.1	–	

**F TYPE BORING BARS** M **THREADING**

### STANDARD OF DEPTH OF CUT ● METRIC SCREW THREAD

- The chart on the right shows the cutting depths when machining internal ISO metric screw threads.
- When using cermet grades or cutting stainless steel, please increase the number of passes by 2–3 times.

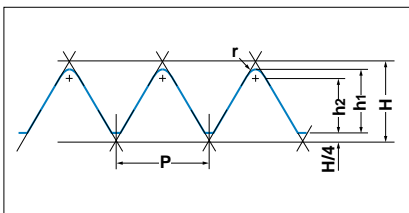

P (Pitch)	0.75	1.00	1.25	1.50	1.75	2.00	2.50	3.00	3.50
<b>h<sub>1</sub></b>	0.43	0.58	0.72	0.87	1.01	1.15	1.44	1.73	2.02
<b>h<sub>2</sub></b>	0.38	0.51	0.63	0.76	0.88	1.01	1.21	1.51	1.77
<b>r (Nose Radius)</b>	0.05	0.07	0.09	0.11	0.13	0.14	0.18	0.22	0.25
<b>Number of Passes</b>	<b>1</b>	0.10	0.15	0.18	0.20	0.23	0.25	0.25	0.30
	<b>2</b>	0.10	0.13	0.15	0.20	0.20	0.20	0.22	0.25
	<b>3</b>	0.10	0.10	0.12	0.15	0.20	0.15	0.20	0.22
	<b>4</b>	0.08	0.10	0.12	0.15	0.15	0.15	0.20	0.20
	<b>5</b>	0.05	0.05	0.10	0.10	0.10	0.15	0.15	0.20
	<b>6</b>		0.05	0.05	0.07	0.08	0.10	0.10	0.15
	<b>7</b>					0.05	0.10	0.10	0.15
	<b>8</b>						0.05	0.10	0.15
	<b>9</b>							0.07	0.10
	<b>10</b>							0.05	0.10
	<b>11</b>								0.05
	<b>12</b>								

(Note) The first pass causes a high load on the cutting edge.  
In order to avoid damage, keep the depth of cut to 0.4–0.5mm maximum.

# INTERNAL THREADING

## F TYPE BORING BARS

- Minimum cutting diameter 23mm.
- Clamp-on type.
- Employing precision breaker.
- Thread pitch  $\leq 2.5\text{mm}$ .

### FCL51

#### Internal threading, Grooving

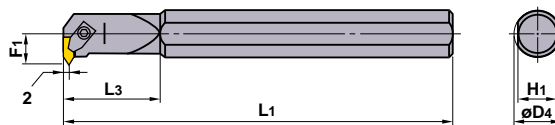
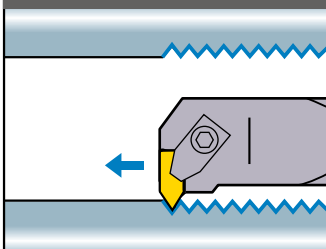

(Note) Cutting in the opposite direction is not possible.

Right hand tool holder shown.

Order Number	Stock		Insert Number		Dimensions (mm)					Min. Cutting Diameter	Clamp Bridge	Clamp Screw	Wrench
	R	L	Threading	Grooving	D4	L1	L3	F1	H1				
<b>FCL5116R/L</b>	●	●			16	200	35	11.5	14	<b>23</b>	LK1	HBH04012	HKY25R
<b>5120R/L</b>	●	●	1600	1250	20	200	35	14.5	18	<b>29</b>	LK1	HBH04012	HKY25R
* <b>5125R/L</b>	●	●	LTL/R1601	LGL/R1390	25	250	40	17.0	22	<b>34</b>	LK1	HBH04012	HKY25R
* <b>5132R/L</b>	●	●	1602	1400	32	300	45	20.0	29	<b>40</b>	LK1	HBH04012	HKY25R

\* 4 sided flat shank.

(Note) When using insert with right or left hand breaker, please use right hand insert for left hand holder and left hand insert for right hand holder.

### STANDARD OF DEPTH OF CUT ● METRIC SCREW THREAD

- The chart on the right shows the cutting depths when machining internal ISO metric screw threads.
- When using cermet grades or cutting stainless steel, please increase the number of passes by 2–3 times.

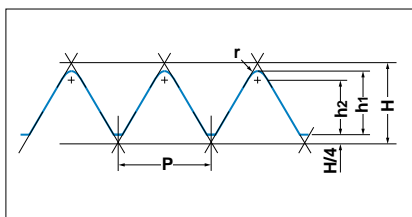

P (Pitch)	0.75	1.00	1.25	1.50	1.75	2.00	2.50
<b>h1</b>	0.43	0.58	0.72	0.87	1.01	1.15	1.44
<b>h2</b>	0.38	0.51	0.63	0.76	0.88	1.01	1.21
<b>r (Nose Radius)</b>	0.05	0.07	0.09	0.11	0.13	0.14	0.18
Number of Passes	<b>1</b>	0.10	0.15	0.18	0.20	0.23	0.25
	<b>2</b>	0.10	0.13	0.15	0.20	0.20	0.22
	<b>3</b>	0.10	0.10	0.12	0.15	0.20	0.15
	<b>4</b>	0.08	0.10	0.12	0.15	0.15	0.15
	<b>5</b>	0.05	0.05	0.10	0.10	0.10	0.15
	<b>6</b>		0.05	0.05	0.07	0.08	0.10
	<b>7</b>					0.05	0.10
	<b>8</b>						0.05
	<b>9</b>						
	<b>10</b>						

(Note) The first pass causes a high load on the cutting edge.

In order to avoid damage, keep the depth of cut to 0.4–0.5mm maximum.

### RECOMMENDED CUTTING CONDITIONS

Work Material	Hardness	Grade	Cutting Speed (m/min)
<b>P</b> Mild Steel	$\leq 180\text{HB}$	<b>NX55</b>	200 (150–250)
		<b>UTi20T</b>	120 (100–150)
Carbon Steel Alloy Steel	180–280HB	<b>NX55</b>	170 (150–200)
		<b>UTi20T</b>	100 (70–120)

Work Material	Hardness	Grade	Cutting Speed (m/min)
<b>M</b> Stainless Steel	$\leq 200\text{HB}$	<b>UTi20T</b>	100 (70–130)
<b>K</b> Cast Iron	Tensile Strength $\leq 350\text{N/mm}^2$	<b>UTi20T</b>	80 (60–100)

## INSERTS

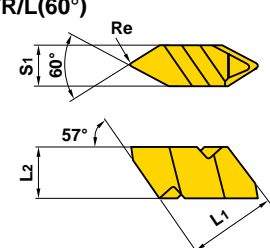
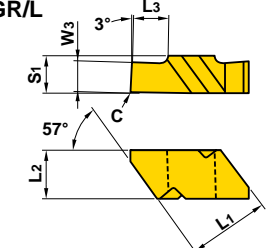
Application	Order Number	Cermet		Carbide	Thread Pitch, Groove Width $W_3$ (mm)	Dimensions (mm)						Geometry
		NX2525	NX55	UT120T		L1	L2	L3	S1	Re	C	
Threading	<b>LTR1600</b>		●	●	0–0.75	10	5	–	4	0	–	<b>LTR/L(60°)</b> 
	<b>L1600</b>		★	●	0–0.75	10	5	–	4	0	–	
	<b>R1601</b>		●	★	1.0–1.75	10	5	–	4	0.1	–	
	<b>L1601</b>		★	●	1.0–1.75	10	5	–	4	0.1	–	
	<b>R1602</b>		●	●	2.0, 2.5	10	5	–	4	0.2	–	
	<b>L1602</b>		★	●	2.0, 2.5	10	5	–	4	0.2	–	
Grooving	<b>LGR1250</b>	□		●	2.5	10	5	3.1	4	–	0.25	<b>LGR/L</b> 
	<b>L1250</b>	★		●	2.5	10	5	3.1	4	–	0.25	
	<b>R1320</b>			●	3.2	10	5	3.1	4	–	0.25	
	<b>L1320</b>	□		●	3.2	10	5	3.1	4	–	0.25	
	<b>R1390</b>			●	3.9	10	5	3.1	4	–	0.25	
	<b>L1390</b>	□		●	3.9	10	5	3.1	4	–	0.25	
	<b>R1400</b>			●	4	10	5	3.1	4	–	0.25	
	<b>L1400</b>	□		★	4	10	5	3.1	4	–	0.25	

### RANGE OF MACHINING

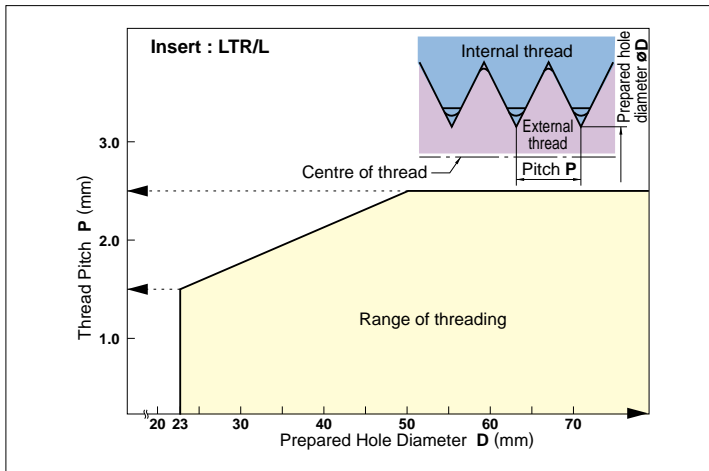

# INTERNAL THREADING

## D TYPE BORING HEAD

- Minimum cutting diameter 40mm.
- Pin lock type.
- Exchangeable head type.
- Thread pitch  $\leq 4.5\text{mm}$ .

### DPT2

### Internal threading

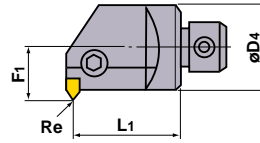
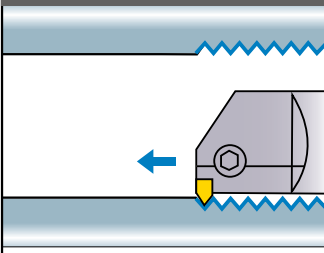

Right hand tool holder only.

Order Number	Stock R	Insert Number	Dimensions (mm)			Min. Cutting Diameter	Standard Corner Radius Re				
			D4	L1	F1						
<b>DPT2132R</b>	★	MTTL4360	32	40	20	<b>40</b>	0.1	P21S	HSP08014	E01	HKY40R
<b>2140R</b>	★		40	50	25	<b>50</b>	0.1	P21S	HSP08014	E01	HKY40R

D TYPE BORING HEAD THREADING

### STANDARD OF DEPTH OF CUT ● METRIC SCREW THREAD

- The chart on the right shows the cutting depths when machining internal ISO metric screw threads.
- When using cermet grades or cutting stainless steel, please increase the number of passes by 2–3 times.

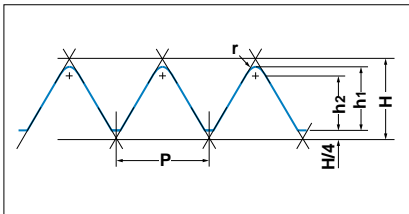

P (Pitch)	0.75	1.00	1.25	1.50	1.75	2.00	2.50	3.00	3.50	4.00	4.50
h1	0.43	0.58	0.72	0.87	1.01	1.15	1.44	1.73	2.02	2.31	2.60
h2	0.38	0.51	0.63	0.76	0.88	1.01	1.21	1.51	1.77	2.02	2.28
r (Nose Radius)	0.05	0.07	0.09	0.11	0.13	0.14	0.18	0.22	0.25	0.29	0.32
Number of Passes	1	0.10	0.15	0.18	0.20	0.23	0.25	0.25	0.25	0.30	0.30
	2	0.10	0.13	0.15	0.20	0.20	0.20	0.22	0.25	0.25	0.25
	3	0.10	0.10	0.12	0.15	0.20	0.15	0.20	0.22	0.22	0.25
	4	0.08	0.10	0.12	0.15	0.15	0.15	0.20	0.20	0.20	0.25
	5	0.05	0.05	0.10	0.10	0.10	0.15	0.15	0.20	0.20	0.23
	6		0.05	0.05	0.07	0.08	0.10	0.10	0.15	0.20	0.20
	7					0.05	0.10	0.10	0.12	0.15	0.20
	8						0.05	0.10	0.10	0.15	0.15
	9							0.07	0.10	0.10	0.15
	10							0.05	0.09	0.10	0.10
	11								0.05	0.10	0.10
	12									0.05	0.08
	13										0.05
	14										

(Note) The first pass causes a high load on the cutting edge.  
In order to avoid damage, keep the depth of cut to 0.4–0.5mm maximum.

### RECOMMENDED CUTTING CONDITIONS

Work Material	Hardness	Grade	Cutting Speed (m/min)
P Mild Steel	$\leq 180\text{HB}$	UP20M	140 (100–180)
		NX55	200 (150–250)
		UTi20T	120 (100–150)
Carbon Steel Alloy Steel	180–280HB	UP20M	120 (100–150)
		NX55	170 (150–200)
		UTi20T	100 (70–120)

Work Material	Hardness	Grade	Cutting Speed (m/min)
M Stainless Steel	$\leq 200\text{HB}$	UP20M	120 (80–150)
		UTi20T	100 (70–130)
K Cast Iron	Tensile Strength $\leq 350\text{N/mm}^2$	UP20M	80 (60–100)
		UTi20T	80 (60–100)
		HTi10	100 (70–130)

## INSERTS

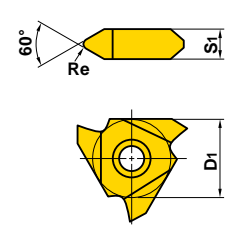
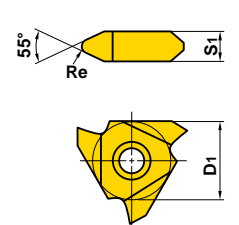
Type	Order Number	Class	Coated		Carbide		ISO Pitch mm (thread/inch)	Dimensions (mm)			Geometry
			UP20M	NX55	UT120T	HT110		D1	S1	Re	
Partial Profile 60°	<b>MTTL436000</b>	G	<input type="checkbox"/>	★	●	<input type="checkbox"/>	- 0.75	12.7	4.76	0	<b>MTTL(60°)</b> 
	<b>L436001</b>	G	<input type="checkbox"/>	★	●	★	1.0-1.75	12.7	4.76	0.1	
	<b>L436002</b>	G	<input type="checkbox"/>	★	●	★	2.0-2.5	12.7	4.76	0.2	
	<b>L436003</b>	G	<input type="checkbox"/>	★	●	<input type="checkbox"/>	3.0-3.5	12.7	4.76	0.3	
	<b>L436004</b>	G	<input type="checkbox"/>	★	★	<input type="checkbox"/>	4.0-4.5	12.7	4.76	0.4	
Partial Profile 55°	<b>MTTL435501</b>	G	<input type="checkbox"/>	★	●	<input type="checkbox"/>	(28-10)	12.7	4.76	0.1	<b>MTTL(55°)</b> 
	<b>L435502</b>	G	<input type="checkbox"/>	★	●	<input type="checkbox"/>	(16-8)	12.7	4.76	0.2	
	<b>L435503</b>	G	<input type="checkbox"/>	★	<input type="checkbox"/>	<input type="checkbox"/>	(11-8)	12.7	4.76	0.3	

## STANDARD ARBOR FOR D TYPE BORING HEAD

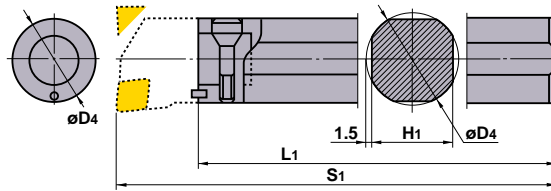

Order Number	Stock	Dimensions (mm)				Set Bolt	Wrench	Head
		D4	L1	H1	S1			
<b>B13232</b>	★	32	260	29	300	SD32	HKY60R	DPT2132R
<b>B14040</b>	★	40	310	37	360	SD40	HKY60R	DPT2140R

## RANGE OF MACHINING

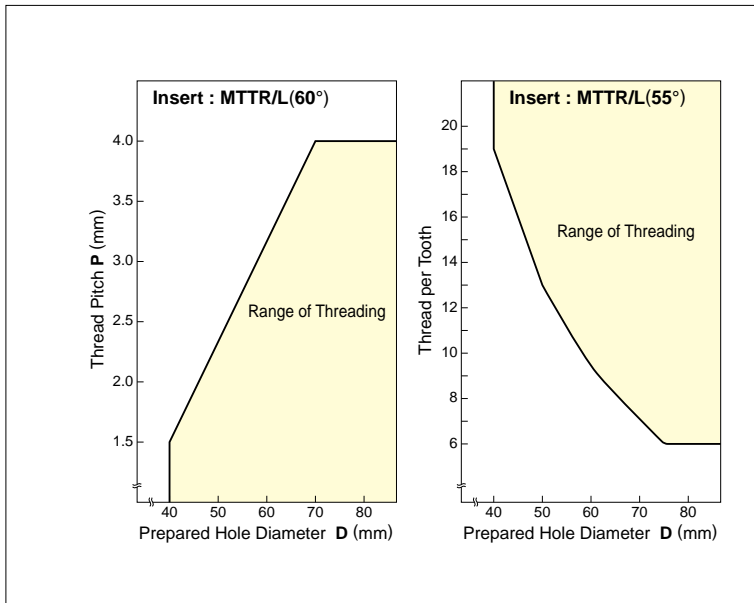

## THREADING METHODS

	Right Hand Thread	Left Hand Thread
EXTERNAL	<p>Holder Reversed</p>	<p>Holder Reversed</p>
INTERNAL		

## INSERT TYPES

Partial Form	Full Form	Semi-Full Form (Trapezoidal threads only)
<ul style="list-style-type: none"> <li>● The same insert can be used for a range of pitches.</li> <li>● Shorter tool life because the nose radius of the insert is smaller than that of the full form insert.</li> <li>● Finishing with another operation is necessary.</li> </ul>	<ul style="list-style-type: none"> <li>● No deburring needed after threading.</li> <li>● Requires different threading inserts.</li> </ul>	<ul style="list-style-type: none"> <li>● No deburring needed after threading.</li> <li>● Requires different threading inserts.</li> <li>● Finishing with another operation is necessary.</li> </ul>
<p>Crest Radius (Additional turning necessary to finish the thread crest.)</p> <p>Finished Surface</p> <p>Pre-finished Surface</p> <p>Feed Direction</p> <p>Insert</p>	<p>Crest Radius (Wiped/finished surface.)</p> <p>Finished Surface</p> <p>Pre-finished Surface</p> <p>Finishing allowance</p> <p>Feed Direction</p> <p>Insert</p>	<p>Crest Radius (Additional turning necessary to finish the thread crest.)</p> <p>Finished Surface</p> <p>Pre-finished Surface</p> <p>Feed Direction</p> <p>Insert</p>

## INFEED METHODS

	Radial Infeed	Flank Infeed	Modified Flank Infeed	Incremental Infeed	
	<p>Radial Infeed</p>	<p>Flank Infeed</p>	<p>Modified Flank Infeed</p>	<p>Incremental Infeed</p>	
Features	Advantages	<ul style="list-style-type: none"> <li>● Easiest to use. (Standard programme for threading)</li> <li>● Wide application. (Cutting conditions easy to change.)</li> <li>● Uniform wear of the right and left sides of the cutting edge.</li> </ul>	<ul style="list-style-type: none"> <li>● Relatively easy to use. (Semi-standard programme for threading.)</li> <li>● Reduced cutting force.</li> <li>● Suitable for large pitch threads or materials that peel easily.</li> <li>● Good chip discharge.</li> </ul>	<ul style="list-style-type: none"> <li>● Preventing flank wear on the right side of the cutting edge.</li> <li>● Reduced cutting force.</li> <li>● Suitable for large pitch threads or materials that peel easily.</li> <li>● Good chip discharge.</li> </ul>	<ul style="list-style-type: none"> <li>● Uniform flank wear of the right and left sides of the cutting edge.</li> <li>● Reduced cutting force.</li> <li>● Suitable for large pitch threads or materials that peel easily.</li> </ul>
	Disadvantages	<ul style="list-style-type: none"> <li>● Difficult chip control.</li> <li>● Subject to vibration in the later in stages of cutting.</li> <li>● Ineffective for large pitch threading.</li> <li>● Heavy load on the nose radius.</li> </ul>	<ul style="list-style-type: none"> <li>● Large flank wear on the right side of the cutting edge.</li> <li>● Relatively difficult to change cutting depth. (Re-programming necessary)</li> </ul>	<ul style="list-style-type: none"> <li>● Complex machining programming.</li> <li>● Difficult to change cutting depth. (Re-programming necessary)</li> </ul>	<ul style="list-style-type: none"> <li>● Complex machining programming.</li> <li>● Difficult to change cutting depth. (Re-programming necessary)</li> <li>● Difficult chip control.</li> </ul>

## THREADING DEPTH

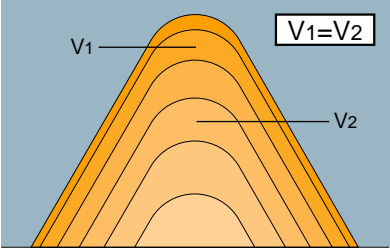
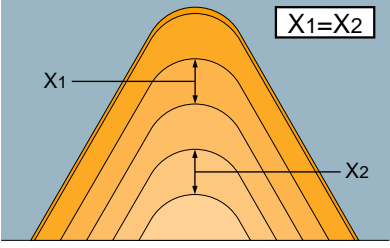
		Features	
		Advantages	Disadvantages
 <p>Fixed cut area</p>	<ul style="list-style-type: none"> <li>● Easy to use. (Standard programme for threading.)</li> <li>● Superior resistance to vibration. (Constant cutting force.)</li> </ul>	<ul style="list-style-type: none"> <li>● Long chips generated during the final pass.</li> <li>● Complex calculation of cutting depth when changing the number of passes.</li> </ul>	
	 <p>Fixed cutting depth</p>	<ul style="list-style-type: none"> <li>● Reduced load on nose radius during the first half of the passes.</li> <li>● Easy chip control. (Optional setting of chip thickness)</li> <li>● Easy to calculate cutting depth when changing the number of passes.</li> <li>● Good chip control.</li> </ul>	<ul style="list-style-type: none"> <li>● Subject to vibration in the later stages of cutting. (Increased cutting force)</li> <li>● In some cases, changing the NC programme is necessary.</li> </ul>

\* It is recommended to set the depth of cut of the final pass to 0.05mm – 0.025mm. Large cutting depths can cause vibration, leading to a poor surface finish.

## ● FORMULAE

### ■ Formulae to calculate infeed for each pass in a reduced series.

$\Delta a_{pn} = \frac{a_p}{\sqrt{n a_p - 1}} \times \sqrt{b}$	<p>(Example) External threading (ISO Metric) Pitch : 1.0mm ap : 0.6mm nap : 5 passes</p>
<p><math>\Delta a_{pn}</math> : Depth of cut n : Actual pass ap : Total depth of cut nap : Number of passes b : 1st pass 0.3 2nd pass 2-1 = 1 3rd pass 3-1 = 2 • • nth pass n-1</p>	<p>1st Pass <math>\Delta a_{p1} = \frac{0.60}{\sqrt{5-1}} \times \sqrt{0.3} = 0.16 \rightarrow \mathbf{0.16} (\Delta a_{p1})</math></p> <p>2nd Pass <math>\Delta a_{p2} = \frac{0.60}{\sqrt{5-1}} \times \sqrt{2-1} = 0.3 \rightarrow \mathbf{0.14} (\Delta a_{p2} - \Delta a_{p1})</math></p> <p>3rd Pass <math>\Delta a_{p3} = \frac{0.60}{\sqrt{5-1}} \times \sqrt{3-1} = 0.42 \rightarrow \mathbf{0.12} (\Delta a_{p3} - \Delta a_{p2})</math></p> <p>4th Pass <math>\Delta a_{p4} = \frac{0.60}{\sqrt{5-1}} \times \sqrt{4-1} = 0.52 \rightarrow \mathbf{0.1} (\Delta a_{p4} - \Delta a_{p3})</math></p> <p>5th Pass <math>\Delta a_{p5} = \frac{0.60}{\sqrt{5-1}} \times \sqrt{5-1} = 0.6 \rightarrow \mathbf{0.08} (\Delta a_{p5} - \Delta a_{p4})</math></p>

## ● NC PROGRAMME FOR MODIFIED FLANK INFEEED

### ■ Example) M12x1.0 5 passes modified 5°

External Threading	Internal Threading
G00 Z = 5.0	G00 Z = 5.0
X = 14.0	X = 10.0
G92 U-4.34 Z- 13.0 F1.0	G92 U4.34 Z- 13.0 F1.0
G00 W-0.07	G00 W-0.07
G92 U-4.64 Z- 13.0 F1.0	G92 U4.64 Z- 13.0 F1.0
G00 W-0.06	G00 W-0.05
G92 U-4.88 Z- 13.0 F1.0	G92 U4.84 Z- 13.0 F1.0
G00 W-0.05	G00 W-0.04
G92 U-5.08 Z- 13.0 F1.0	G92 U5.02 Z- 13.0 F1.0
G00 W-0.03	G00 W-0.03
G92 U-5.20 Z- 13.0 F1.0	G92 U5.14 Z- 13.0 F1.0
G00	G00

## SELECTING CUTTING CONDITIONS

		Priority					
		Tool Life	Cutting Force	Surface Finish	Precision of Thread	Chips Discharge	Efficiency (Reduced Passes)
Threading Methods	Radial	○		○	○		○
	Flank	(△ : Modified)	○	(△ : Modified)		○	
Cutting Depth	Fixed Cutting Depth					○	
	Fixed Cut Area	○	○	○	○		○

- \* Tool life and surface finish accuracy can be increased by changing the threading method from flank infeed to modified flank infeed.
- \* Chip control can be improved by increasing the cutting depth in the later half of passes.

## CUTTING DEPTH AND THE NUMBER OF PASSES

### ■ Selection of the appropriate cutting depth and the right number of passes is vital for threading.

- For most threading, use a "threading cycle program," which has originally been installed on machines, and specify "total cutting depth" and "cutting depth in the first or final pass."
- Cutting depth and the number of passes are easy to change for the radial infeed method, thus making it easy to determine the appropriate cutting conditions.

## FEATURES AND BENEFITS OF MITSUBISHI PRODUCTS

- Insert grades with high wear and plastic deformation resistance, specially produced for threading tools, ensure highly efficient cutting by enabling high-speed machining and a reduced number of passes.



Machining Cost Reduction

## ADVICE ON IMPROVED THREADING

### ■ Increasing tool life

- To prevent damage to the nose radius - *Recommended method - Modified flank infeed.*
- To have uniform flank wear on both sides of a cutting edge - *Recommended method - Radial infeed*
- To prevent crater wear - *Recommended method - Flank infeed*

### ■ Preventing chip problems

- Change to flank or modified infeed.
- During radial infeed cutting, use an inverted holder and change the coolant supply to a downward direction.
- When using the radial infeed method, set the minimum cutting depth at around 0.2mm to make the chips thicker.

### ■ To achieve highly efficient machining

- Increase cutting speed. (Dependant on the maximum revolution and rigidity of the machine.)
- Reduce the number of passes. (Reduce by 30-40%.)
- A reduced number of passes can improve chip discharge because of the thicker chips generated.

### ■ Preventing vibration

- Change to flank or modified infeed.
- When using radial infeed, reduce cutting depth in the later half of passes and lower the cutting speed.

### ■ Increased surface finish accuracy

- A final wiping pass should be performed at the same depth of cut as the last regular pass.
- When using the flank infeed method, change to radial infeed only during the final pass.

## SELECTING A SHIM FOR THE MMT SERIES

### FLANK ANGLE AND LEAD ANGLE

Lead angle ( $\alpha$ ) depends on a combination of thread diameter and pitch. Select a shim so that the lead angle of the thread can coincide with the flank angles of the thread and insert ( $\beta_1, \beta_2$ ). No need to change a shim for general threading with an MMT holder. When threading with a small diameter or large pitch, change the shim depending on the lead angle, referring to the table and graph below. When threading left hand threads, change to a shim with a negative inclination angle.

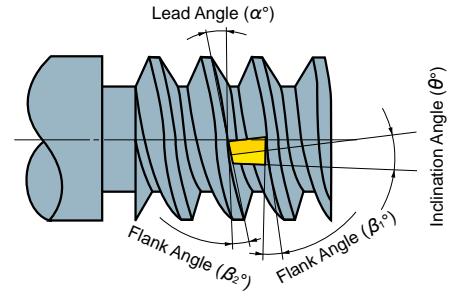

### SHIM REFERENCE TABLE (THREADING DIAMETER)

Lead Angle Pitch (mm)	Right Hand Thread (mm)						Left Hand Thread (mm)		
	Threading impossible	4.5°	3.5°	2.5°	1.5°	0.5°	Threading impossible	-1.5°	-0.5°
0.5	$\leq \phi 1.9$	$\phi 1.9 - \phi 2.2$	$\phi 2.2 - \phi 2.8$	$\phi 2.8 - \phi 4.3$	$\phi 4.3 - \phi 11.4$	$\geq \phi 11.4$	$\leq \phi 4.3$	$\phi 4.3 - \phi 11.4$	$\geq \phi 11.4$
0.75	$\leq \phi 2.9$	$\phi 2.9 - \phi 3.2$	$\phi 3.2 - \phi 4.3$	$\phi 4.3 - \phi 6.5$	$\phi 6.5 - \phi 17.1$	$\geq \phi 17.1$	$\leq \phi 6.5$	$\phi 6.5 - \phi 17.1$	$\geq \phi 17.1$
1	$\leq \phi 3.8$	$\phi 3.8 - \phi 4.3$	$\phi 4.3 - \phi 5.7$	$\phi 5.7 - \phi 8.7$	$\phi 8.7 - \phi 22.8$	$\geq \phi 22.8$	$\leq \phi 8.7$	$\phi 8.7 - \phi 22.8$	$\geq \phi 22.8$
1.25	$\leq \phi 4.8$	$\phi 4.8 - \phi 5.4$	$\phi 5.4 - \phi 7.1$	$\phi 7.1 - \phi 10.9$	$\phi 10.9 - \phi 28.5$	$\geq \phi 28.5$	$\leq \phi 10.9$	$\phi 10.9 - \phi 28.5$	$\geq \phi 28.5$
1.5	$\leq \phi 5.7$	$\phi 5.7 - \phi 6.5$	$\phi 6.5 - \phi 8.5$	$\phi 8.5 - \phi 13.0$	$\phi 13.0 - \phi 34.2$	$\geq \phi 34.2$	$\leq \phi 13.0$	$\phi 13.0 - \phi 34.2$	$\geq \phi 34.2$
1.75	$\leq \phi 6.7$	$\phi 6.7 - \phi 7.6$	$\phi 7.6 - \phi 9.9$	$\phi 9.9 - \phi 15.2$	$\phi 15.2 - \phi 39.9$	$\geq \phi 39.9$	$\leq \phi 15.2$	$\phi 15.2 - \phi 39.9$	$\geq \phi 39.9$
2	$\leq \phi 7.6$	$\phi 7.6 - \phi 8.6$	$\phi 8.6 - \phi 11.4$	$\phi 11.4 - \phi 17.4$	$\phi 17.4 - \phi 45.6$	$\geq \phi 45.6$	$\leq \phi 17.4$	$\phi 17.4 - \phi 45.6$	$\geq \phi 45.6$
2.5	$\leq \phi 9.5$	$\phi 9.5 - \phi 10.8$	$\phi 10.8 - \phi 14.2$	$\phi 14.2 - \phi 21.7$	$\phi 21.7 - \phi 57.0$	$\geq \phi 57.0$	$\leq \phi 21.7$	$\phi 21.7 - \phi 57.0$	$\geq \phi 57.0$
3	$\leq \phi 11.4$	$\phi 11.4 - \phi 13.0$	$\phi 13.0 - \phi 17.0$	$\phi 17.0 - \phi 26.0$	$\phi 26.0 - \phi 68.4$	$\geq \phi 68.4$	$\leq \phi 26.0$	$\phi 26.0 - \phi 68.4$	$\geq \phi 68.4$
3.5	$\leq \phi 13.3$	$\phi 13.3 - \phi 15.1$	$\phi 15.1 - \phi 19.9$	$\phi 19.9 - \phi 30.4$	$\phi 30.4 - \phi 79.8$	$\geq \phi 79.8$	$\leq \phi 30.4$	$\phi 30.4 - \phi 79.8$	$\geq \phi 79.8$
4	$\leq \phi 15.2$	$\phi 15.2 - \phi 17.3$	$\phi 17.3 - \phi 22.7$	$\phi 22.7 - \phi 34.7$	$\phi 34.7 - \phi 91.2$	$\geq \phi 91.2$	$\leq \phi 34.7$	$\phi 34.7 - \phi 91.2$	$\geq \phi 91.2$
4.5	$\leq \phi 17.1$	$\phi 17.1 - \phi 19.4$	$\phi 19.4 - \phi 25.6$	$\phi 25.6 - \phi 39.1$	$\phi 39.1 - \phi 102.6$	$\geq \phi 102.6$	$\leq \phi 39.1$	$\phi 39.1 - \phi 102.6$	$\geq \phi 102.6$
5	$\leq \phi 19.0$	$\phi 19.0 - \phi 21.6$	$\phi 21.6 - \phi 28.4$	$\phi 28.4 - \phi 43.4$	$\phi 43.4 - \phi 114.0$	$\geq \phi 114.0$	$\leq \phi 43.4$	$\phi 43.4 - \phi 114.0$	$\geq \phi 114.0$

(Note) Back turning in the case of left hand threads.

### SHIM REFERENCE GRAPH

#### Right Hand Thread

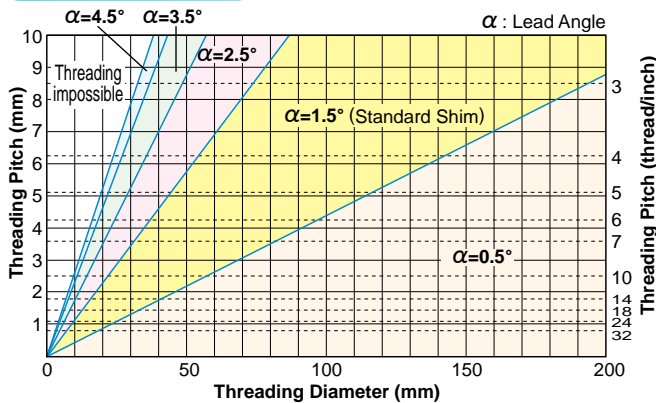

#### Left Hand Thread

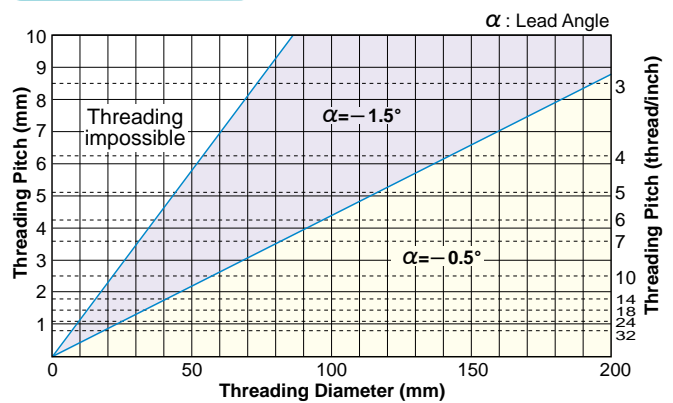

(Note) When a thread lead angle  $\leq$  the tool flank angle, change the shim to prevent side interference with the insert.  
(Refer to the table below for the calculation of thread lead angle and tool flank angle.)

When replacing a shim, check if the difference between the thread lead angle and shim inclination angle is within:

2.5° – 0.5° where thread helix angle is 60° (55°)

2° – 1° where thread helix angle is 30° (29°)

\* Inclination angle of a standard shim is 0°.

\* The holder has a 1.5° lead angle.

### CALCULATION OF THREAD LEAD ANGLE

$$\tan \alpha = \frac{l}{\pi d} = \frac{nP}{\pi d}$$

$\alpha$  : Lead angle  
 $l$  : Lead  
 $n$  : Number of threads  
 $P$  : Pitch  
 $d$  : Effective diameter of thread

### EXAMPLE OF SELECTING A SHIM

- When the thread lead angle is 2.2°
  - In the case when the thread helix angle is 60°  
 (2.2° lead angle) – (2.5 – 0.5°) = -0.3° – 1.7° shim inclination angle is appropriate.  
 Threading with a standard shim (0° inclination angle) is possible. But, replacing with a shim with a 1° inclination angle is recommended, refer to Standard Shim List on pages A330 and A331.
  - In the case when the thread helix angle is 30°  
 (2.2° lead angle) – (2 – 1°) = -0.2° – 1.2° shim inclination angle is appropriate.  
 Replacing with a shim with a 1° inclination angle is recommended, referring to Standard Shim List on pages A330 and A331.

### RELIEF ANGLE OF AN INSERT SET ON A HOLDER

Thread Helix Angle	Internal Relief Angle	External Relief Angle
60°	8.5°	6°
55°	7°	7°
30°	4°	2.5°
29°	4°	2.5°

- Relief angles ( $\beta_2, \beta_1$ ) of an insert become small when the thread helix angle of a trapezoidal, round, or other thread is small. Take care when selecting a shim.

## STANDARD OF DEPTH OF CUT EXTERNAL (RADIAL INFED)

### ISO Metric

Pitch (mm)	Total Cutting Depth	Number of Passes														Insert Type			
		1	2	3	4	5	6	7	8	9	10	11	12	13	14	G-class ground inserts	M-class inserts with 3-D chip breakers		
0.5	0.31	0.10	0.08	0.07	0.06													MMT16ER050ISO	—
0.75	0.46	0.16	0.14	0.10	0.06													16ER075ISO	—
1.0	0.61	0.18	0.15	0.12	0.10	0.06												16ER100ISO	MMT16ER100ISO-S
1.25	0.77	0.19	0.17	0.14	0.11	0.10	0.06											16ER125ISO	16ER125ISO-S
1.5	0.92	0.22	0.21	0.17	0.14	0.12	0.06											16ER150ISO	16ER150ISO-S
1.75	1.07	0.22	0.21	0.16	0.13	0.11	0.09	0.09	0.06									16ER175ISO	16ER175ISO-S
2.0	1.23	0.24	0.23	0.17	0.16	0.14	0.12	0.11	0.06									16ER200ISO	16ER200ISO-S
2.5	1.53	0.26	0.23	0.19	0.17	0.15	0.13	0.12	0.11	0.11	0.06							16ER250ISO	16ER250ISO-S
3.0	1.84	0.27	0.25	0.20	0.18	0.16	0.14	0.13	0.12	0.12	0.11	0.10	0.06					16ER300ISO	16ER300ISO-S
3.5	2.15	0.33	0.30	0.24	0.21	0.18	0.17	0.15	0.14	0.14	0.12	0.11	0.06					22ER350ISO	—
4.0	2.45	0.34	0.31	0.24	0.22	0.19	0.17	0.16	0.14	0.14	0.13	0.12	0.12	0.11	0.06			22ER400ISO	—
4.5	2.76	0.38	0.34	0.28	0.24	0.22	0.20	0.18	0.16	0.16	0.15	0.14	0.13	0.12	0.06			22ER450ISO	—
5.0	3.07	0.42	0.38	0.32	0.27	0.24	0.22	0.20	0.18	0.18	0.17	0.16	0.15	0.12	0.06			22ER500ISO	—

### American UN

Pitch (thread/inch)	Total Cutting Depth	Number of Passes														Insert Type			
		1	2	3	4	5	6	7	8	9	10	11	12	13	14	G-class ground inserts	M-class inserts with 3-D chip breakers		
32	0.49	0.17	0.15	0.11	0.06													MMT16ER320UN	—
28	0.56	0.17	0.14	0.10	0.09	0.06												16ER280UN	—
24	0.65	0.18	0.16	0.14	0.11	0.06												16ER240UN	—
20	0.78	0.20	0.18	0.13	0.11	0.10	0.06											16ER200UN	—
18	0.87	0.22	0.20	0.15	0.13	0.11	0.06											16ER180UN	—
16	0.97	0.22	0.20	0.15	0.12	0.11	0.11	0.06										16ER160UN	MMT16ER160UN-S
14	1.11	0.23	0.21	0.16	0.13	0.11	0.11	0.10	0.06									16ER140UN	16ER140UN-S
13	1.20	0.25	0.22	0.17	0.14	0.13	0.12	0.11	0.06									16ER130UN	—
12	1.30	0.28	0.23	0.18	0.16	0.14	0.13	0.12	0.06									16ER120UN	MMT16ER120UN-S
11	1.42	0.28	0.23	0.19	0.16	0.14	0.13	0.12	0.11	0.06								16ER110UN	—
10	1.56	0.28	0.24	0.19	0.16	0.14	0.13	0.13	0.12	0.11	0.06							16ER100UN	—
9	1.73	0.34	0.29	0.22	0.17	0.15	0.14	0.13	0.12	0.11	0.06							16ER090UN	—
8	1.95	0.35	0.30	0.24	0.19	0.16	0.15	0.14	0.13	0.12	0.11	0.06						16ER080UN	—
7	2.22	0.37	0.33	0.28	0.24	0.20	0.17	0.16	0.15	0.14	0.12	0.06						22ER070UN	—
6	2.60	0.42	0.35	0.29	0.25	0.21	0.18	0.17	0.16	0.15	0.13	0.12	0.11	0.06				22ER060UN	—
5	3.12	0.43	0.39	0.31	0.27	0.24	0.22	0.20	0.19	0.19	0.18	0.17	0.15	0.12	0.06			22ER050UN	—

### Whitworth for BSW, BSP

Pitch (thread/inch)	Total Cutting Depth	Number of Passes														Insert Type			
		1	2	3	4	5	6	7	8	9	10	11	12	13	14	G-class ground inserts	M-class inserts with 3-D chip breakers		
28	0.58	0.17	0.14	0.11	0.10	0.06												MMT16ER280W	—
26	0.63	0.18	0.15	0.13	0.11	0.06												16ER260W	—
20	0.81	0.20	0.18	0.14	0.12	0.11	0.06											16ER200W	—
19	0.86	0.21	0.19	0.15	0.13	0.12	0.06											16ER190W	MMT16ER190W-S
18	0.90	0.25	0.19	0.15	0.13	0.12	0.06											16ER180W	—
16	1.02	0.21	0.18	0.15	0.13	0.11	0.09	0.09	0.06									16ER160W	—
14	1.16	0.23	0.21	0.17	0.14	0.12	0.12	0.11	0.06									16ER140W	MMT16ER140W-S
12	1.36	0.27	0.25	0.20	0.16	0.15	0.14	0.13	0.06									16ER120W	—
11	1.48	0.27	0.24	0.20	0.17	0.15	0.14	0.13	0.12	0.06								16ER110W	MMT16ER110W-S
10	1.63	0.27	0.25	0.20	0.17	0.15	0.15	0.13	0.13	0.12	0.06							16ER100W	—
9	1.81	0.28	0.26	0.21	0.18	0.16	0.15	0.14	0.13	0.12	0.12	0.06						16ER090W	—
8	2.03	0.30	0.27	0.22	0.19	0.17	0.16	0.15	0.14	0.13	0.12	0.12	0.06					16ER080W	—
7	2.32	0.34	0.32	0.26	0.22	0.20	0.18	0.17	0.16	0.15	0.14	0.12	0.06					22ER070W	—
6	2.71	0.35	0.33	0.27	0.23	0.21	0.20	0.19	0.17	0.16	0.15	0.14	0.13	0.12	0.06			22ER060W	—
5	3.25	0.42	0.40	0.35	0.29	0.26	0.24	0.22	0.20	0.19	0.18	0.17	0.15	0.12	0.06			22ER050W	—

### BSPT

Pitch (thread/inch)	Total Cutting Depth	Number of Passes														Insert Type			
		1	2	3	4	5	6	7	8	9						G-class ground inserts	M-class inserts with 3-D chip breakers		
28	0.58	0.17	0.14	0.11	0.10	0.06												MMT16ER280BSPT	—
19	0.86	0.22	0.19	0.15	0.12	0.12	0.06											16ER190BSPT	MMT16ER190BSPT-S
14	1.16	0.24	0.20	0.17	0.14	0.12	0.12	0.11	0.06									16ER140BSPT	16ER140BSPT-S
11	1.48	0.25	0.23	0.21	0.18	0.16	0.14	0.13	0.12	0.06								16ER110BSPT	16ER110BSPT-S

(Note) • Set the finishing allowance on a diameter at approx. 0.1mm when using a full form insert.

- Please note the cutting depth and the number of passes when a nose radius of a partial form insert or of an internal threading insert is small to prevent damage to the insert nose.
- Please set the cutting depth sufficiently deep enough on materials such as hardened steel or austenitic stainless steel to help prevent premature wear and chipping caused by the outer layer of the material.

**Round DIN 405**

Pitch (thread/inch)	Total Cutting Depth	Number of Passes														Insert Type	
		1	2	3	4	5	6	7	8	9	10	11	12	13	14		
10	1.27	0.23	0.21	0.20	0.19	0.16	0.12	0.10	0.06								MMT16ER100RD
8	1.59	0.23	0.21	0.20	0.19	0.18	0.16	0.14	0.12	0.10	0.06						16ER080RD
6	2.12	0.26	0.25	0.24	0.22	0.21	0.19	0.17	0.16	0.14	0.12	0.10	0.06				16ER060RD
4	3.18	0.34	0.33	0.32	0.30	0.28	0.26	0.24	0.22	0.20	0.19	0.17	0.15	0.12	0.06		22ER040RD

**ISO Trapezoidal 30°**

Pitch (mm)	Total Cutting Depth	Number of Passes														Insert Type	
		1	2	3	4	5	6	7	8	9	10	11	12	13	14		
1.5	0.90	0.23	0.21	0.16	0.13	0.11	0.06										MMT16ER150TR
2.0	1.25	0.29	0.26	0.21	0.17	0.14	0.12	0.06									16ER200TR
3.0	1.75	0.32	0.31	0.24	0.19	0.18	0.17	0.15	0.13	0.06							16ER300TR
4.0	2.25	0.33	0.32	0.24	0.22	0.21	0.17	0.16	0.15	0.14	0.13	0.12	0.16				22ER400TR
5.0	2.75	0.35	0.32	0.26	0.24	0.22	0.21	0.19	0.19	0.17	0.15	0.14	0.13	0.12	0.06		22ER500TR

**American ACME**

Pitch (thread/inch)	Total Cutting Depth	Number of Passes														Insert Type	
		1	2	3	4	5	6	7	8	9	10	11	12	13	14		
12	1.19	0.27	0.23	0.20	0.17	0.14	0.12	0.06									MMT16ER120ACME
10	1.52	0.29	0.25	0.21	0.18	0.16	0.14	0.12	0.11	0.06							16ER100ACME
8	1.84	0.30	0.26	0.22	0.19	0.16	0.15	0.14	0.13	0.12	0.11	0.06					16ER080ACME
6	2.37	0.34	0.30	0.27	0.24	0.21	0.19	0.16	0.14	0.12	0.12	0.11	0.11	0.06			22ER060ACME
5	2.79	0.36	0.33	0.30	0.26	0.23	0.20	0.18	0.17	0.16	0.15	0.14	0.13	0.12	0.06		22ER050ACME

**UNJ**

Pitch (thread/inch)	Total Cutting Depth	Number of Passes														Insert Type	
		1	2	3	4	5	6	7	8	9	10	11					
32	0.46	0.16	0.14	0.10	0.06												MMT16ER320UNJ
28	0.52	0.16	0.12	0.09	0.09	0.06											16ER280UNJ
24	0.61	0.17	0.14	0.14	0.10	0.06											16ER240UNJ
20	0.73	0.19	0.16	0.13	0.10	0.09	0.06										16ER200UNJ
18	0.81	0.23	0.18	0.14	0.10	0.10	0.06										16ER180UNJ
16	0.92	0.26	0.21	0.14	0.12	0.10	0.09										16ER160UNJ
14	1.05	0.26	0.23	0.17	0.12	0.11	0.10	0.06									16ER140UNJ
12	1.22	0.28	0.27	0.20	0.17	0.13	0.11	0.06									16ER120UNJ
10	1.47	0.30	0.29	0.21	0.15	0.13	0.12	0.11	0.10	0.06							16ER100UNJ
8	1.83	0.31	0.30	0.23	0.18	0.15	0.14	0.13	0.12	0.11	0.10	0.06					16ER080UNJ

**API Buttress Casing**

Pitch (thread/inch)	Total Cutting Depth	Number of Passes														Insert Type	
		1	2	3	4	5	6	7	8	9	10	11					
5	1.55	0.25	0.23	0.17	0.15	0.13	0.12	0.12	0.11	0.11	0.10	0.06					MMT22ER050APBU

**API Round Casing&Tubing**

Pitch (thread/inch)	Total Cutting Depth	Number of Passes														Insert Type	
		1	2	3	4	5	6	7	8	9	10	11	12				
10	1.41	0.25	0.23	0.16	0.14	0.12	0.12	0.12	0.11	0.10	0.06						MMT16ER100APRD
8	1.81	0.25	0.24	0.19	0.16	0.14	0.14	0.13	0.13	0.13	0.13	0.13	0.11	0.06			16ER080APRD

**American NPT**

Pitch (thread/inch)	Total Cutting Depth	Number of Passes															Insert Type
		1	2	3	4	5	6	7	8	9	10	11	12	13	14	15	
27	0.66	0.15	0.13	0.12	0.11	0.09	0.06										MMT16ER270NPT
18	1.01	0.20	0.16	0.14	0.13	0.12	0.11	0.09	0.06								16ER180NPT
14	1.33	0.23	0.19	0.16	0.14	0.13	0.12	0.11	0.10	0.09	0.06						16ER140NPT
11.5	1.64	0.24	0.19	0.17	0.15	0.15	0.13	0.13	0.12	0.11	0.10	0.09	0.06				16ER115NPT
8	2.42	0.33	0.28	0.23	0.20	0.18	0.16	0.15	0.14	0.13	0.12	0.12	0.11	0.11	0.10	0.06	16ER080NPT

**American NPTF**

Pitch (thread/inch)	Total Cutting Depth	Number of Passes															Insert Type
		1	2	3	4	5	6	7	8	9	10	11	12	13	14	15	
27	0.64	0.16	0.14	0.11	0.09	0.08	0.06										MMT16ER270NPTF
18	1.00	0.19	0.16	0.14	0.13	0.12	0.11	0.09	0.06								16ER180NPTF
14	1.35	0.23	0.21	0.16	0.14	0.13	0.12	0.11	0.10	0.09	0.06						16ER140NPTF
11.5	1.63	0.24	0.23	0.19	0.15	0.13	0.11	0.11	0.11	0.10	0.10	0.10	0.06				16ER115NPTF
8	2.38	0.32	0.27	0.23	0.19	0.17	0.16	0.15	0.14	0.13	0.12	0.12	0.11	0.11	0.10	0.06	16ER080NPTF

- (Note) • Set the finishing allowance on a diameter at approx. 0.1mm when using a full form insert.  
 • Please note the cutting depth and the number of passes when a nose radius of a partial form insert or of an internal threading insert is small to prevent damage to the insert nose.  
 • Please set the cutting depth sufficiently deep enough on materials such as hardened steel or austenitic stainless steel to help prevent premature wear and chipping caused by the outer layer of the material.

## STANDARD OF DEPTH OF CUT INTERNAL (RADIAL INFED)

### ISO Metric

Pitch (mm)	Total Cutting Depth	Number of Passes														Insert Type			
		1	2	3	4	5	6	7	8	9	10	11	12	13	14	G-class ground inserts		M-class inserts with 3-D chip breakers	
0.5	0.29	0.09	0.07	0.07	0.06											MMT11R050ISO	MMT16R050ISO	—	—
0.75	0.43	0.15	0.13	0.09	0.06											11R075ISO	16R075ISO	—	—
1.0	0.58	0.17	0.15	0.11	0.09	0.06										11R100ISO	16R100ISO	MMT11R100ISO-S	MMT16R100ISO-S
1.25	0.72	0.18	0.16	0.12	0.11	0.09	0.06									11R125ISO	16R125ISO	11R125ISO-S	16R125ISO-S
1.5	0.87	0.21	0.20	0.16	0.13	0.11	0.06									11R150ISO	16R150ISO	11R150ISO-S	16R150ISO-S
1.75	1.01	0.21	0.20	0.15	0.12	0.10	0.09	0.08	0.06							11R175ISO	16R175ISO	—	16R175ISO-S
2.0	1.15	0.24	0.22	0.18	0.14	0.12	0.10	0.09	0.06							11R200ISO	16R200ISO	—	16R200ISO-S
2.5	1.44	0.25	0.24	0.21	0.15	0.13	0.12	0.10	0.09	0.09	0.06					—	16R250ISO	—	16R250ISO-S
3.0	1.73	0.26	0.25	0.22	0.17	0.14	0.13	0.12	0.11	0.10	0.09	0.08	0.06			—	16R300ISO	—	16R300ISO-S
3.5	2.02	0.32	0.30	0.23	0.19	0.17	0.15	0.14	0.13	0.12	0.11	0.10	0.06			—	22R350ISO	—	—
4.0	2.31	0.33	0.31	0.24	0.22	0.18	0.15	0.14	0.13	0.12	0.12	0.11	0.10	0.10	0.06	—	22R400ISO	—	—
4.5	2.60	0.36	0.33	0.28	0.24	0.21	0.19	0.16	0.15	0.14	0.13	0.12	0.12	0.11	0.06	—	22R450ISO	—	—
5.0	2.89	0.41	0.38	0.32	0.27	0.24	0.21	0.18	0.16	0.15	0.14	0.13	0.12	0.12	0.06	—	22R500ISO	—	—

### American UN

Pitch (thread/inch)	Total Cutting Depth	Number of Passes														Insert Type			
		1	2	3	4	5	6	7	8	9	10	11	12	13	14	G-class ground inserts		M-class inserts with 3-D chip breakers	
32	0.46	0.16	0.14	0.10	0.06											MMT11R320UN	MMT16R320UN	—	—
28	0.52	0.16	0.13	0.09	0.08	0.06										11R280UN	16R280UN	—	—
24	0.61	0.17	0.15	0.13	0.10	0.06										11R240UN	16R240UN	—	—
20	0.73	0.18	0.15	0.13	0.11	0.10	0.06									11R200UN	16R200UN	—	—
18	0.81	0.20	0.18	0.14	0.12	0.11	0.06									11R180UN	16R180UN	—	—
16	0.92	0.20	0.18	0.15	0.12	0.11	0.10	0.06								11R160UN	16R160UN	MMT16R160UN-S	—
14	1.05	0.21	0.18	0.15	0.13	0.11	0.11	0.10	0.06							11R140UN	16R140UN	16R140UN-S	—
13	1.13	0.22	0.19	0.16	0.14	0.13	0.12	0.11	0.06							—	16R130UN	—	—
12	1.22	0.24	0.22	0.18	0.16	0.13	0.12	0.11	0.06							—	16R120UN	MMT16R120UN-S	—
11	1.33	0.24	0.22	0.20	0.15	0.12	0.12	0.11	0.11	0.06						—	16R110UN	—	—
10	1.47	0.25	0.22	0.21	0.14	0.13	0.12	0.12	0.11	0.11	0.06					—	16R100UN	—	—
9	1.63	0.31	0.23	0.21	0.17	0.15	0.14	0.13	0.12	0.11	0.06					—	16R090UN	—	—
8	1.83	0.31	0.26	0.21	0.18	0.16	0.15	0.14	0.13	0.12	0.11	0.06				—	16R080UN	—	—
7	2.09	0.36	0.30	0.24	0.21	0.18	0.17	0.16	0.15	0.14	0.12	0.06				—	22R070UN	—	—
6	2.44	0.40	0.33	0.25	0.23	0.19	0.17	0.16	0.15	0.14	0.13	0.12	0.11	0.06		—	22R060UN	—	—
5	2.93	0.41	0.35	0.31	0.26	0.23	0.21	0.20	0.19	0.17	0.15	0.14	0.13	0.12	0.06	—	22R050UN	—	—

### Whitworth for BSW, BSP

Pitch (thread/inch)	Total Cutting Depth	Number of Passes														Insert Type			
		1	2	3	4	5	6	7	8	9	10	11	12	13	14	G-class ground inserts		M-class inserts with 3-D chip breakers	
28	0.58	0.17	0.14	0.11	0.10	0.06										—	MMT16R280W	—	—
26	0.63	0.18	0.15	0.13	0.11	0.06										—	16R260W	—	—
20	0.81	0.20	0.18	0.14	0.12	0.11	0.06									—	16R200W	—	—
19	0.86	0.21	0.19	0.15	0.13	0.12	0.06									MMT11R190W	16R190W	MMT16R190W-S	—
18	0.90	0.25	0.19	0.15	0.13	0.12	0.06									—	16R180W	—	—
16	1.02	0.21	0.18	0.15	0.13	0.11	0.09	0.09	0.06							—	16R160W	—	—
14	1.16	0.23	0.21	0.17	0.14	0.12	0.12	0.11	0.06							MMT11R140W	16R140W	MMT16R140W-S	—
12	1.36	0.27	0.25	0.20	0.16	0.15	0.14	0.13	0.06							—	16R120W	16R120W-S	—
11	1.48	0.27	0.24	0.20	0.17	0.15	0.14	0.13	0.12	0.06						—	16R110W	—	—
10	1.63	0.27	0.25	0.20	0.17	0.15	0.15	0.13	0.13	0.12	0.06					—	16R100W	—	—
9	1.81	0.28	0.26	0.21	0.18	0.16	0.15	0.14	0.13	0.12	0.12	0.06				—	16R090W	—	—
8	2.03	0.30	0.27	0.22	0.19	0.17	0.16	0.15	0.14	0.13	0.12	0.12	0.06			—	16R080W	—	—
7	2.32	0.34	0.32	0.26	0.22	0.20	0.18	0.17	0.16	0.15	0.14	0.12	0.06			—	22R070W	—	—
6	2.71	0.35	0.33	0.27	0.23	0.21	0.20	0.19	0.17	0.16	0.15	0.14	0.13	0.12	0.06	—	22R060W	—	—
5	3.25	0.42	0.40	0.35	0.29	0.26	0.24	0.22	0.20	0.19	0.18	0.17	0.15	0.12	0.06	—	22R050W	—	—

(Note) • Set the finishing allowance on a diameter at approx. 0.1mm when using a full form insert.

- Please note the cutting depth and the number of passes when a nose radius of a partial form insert or of an internal threading insert is small to prevent damage to the insert nose.
- Please set the cutting depth sufficiently deep enough on materials such as hardened steel or austenitic stainless steel to help prevent premature wear and chipping caused by the outer layer of the material.

**BSPT**

Pitch (thread/inch)	Total Cutting Depth	Number of Passes														Insert Type				
		1	2	3	4	5	6	7	8	9								G-class ground inserts	M-class inserts with 3-D chip breakers	
19	0.86	0.22	0.19	0.15	0.12	0.12	0.06											MMT11R190BSPT	MMT16R190BSPT	MMT16R190BSPT-S
14	1.16	0.24	0.20	0.17	0.14	0.12	0.12	0.11	0.06									11R140BSPT	16R140BSPT	16R140BSPT-S
11	1.48	0.25	0.23	0.21	0.18	0.16	0.14	0.13	0.12	0.06								—	16R110BSPT	16R110BSPT-S

**Round DIN 405**

Pitch (thread/inch)	Total Cutting Depth	Number of Passes														Insert Type				
		1	2	3	4	5	6	7	8	9	10	11	12	13	14					
10	1.27	0.23	0.21	0.20	0.19	0.16	0.12	0.10	0.06											MMT16R100RD
8	1.59	0.23	0.21	0.20	0.19	0.18	0.16	0.14	0.12	0.10	0.06									16R080RD
6	2.12	0.26	0.25	0.24	0.22	0.21	0.19	0.17	0.16	0.14	0.12	0.10	0.06							16R060RD
4	3.18	0.34	0.33	0.32	0.30	0.28	0.26	0.24	0.22	0.20	0.19	0.17	0.15	0.12	0.06					22R040RD

**ISO Trapezoidal 30°**

Pitch (mm)	Total Cutting Depth	Number of Passes														Insert Type				
		1	2	3	4	5	6	7	8	9	10	11	12	13	14					
1.5	0.90	0.23	0.21	0.16	0.13	0.11	0.06													MMT16R150TR
2	1.25	0.29	0.26	0.21	0.17	0.14	0.12	0.06												16R200TR
3	1.75	0.32	0.31	0.24	0.19	0.18	0.17	0.15	0.13	0.06										16R300TR
4	2.25	0.33	0.32	0.24	0.22	0.21	0.17	0.16	0.15	0.14	0.13	0.12	0.06							22R400TR
5	2.75	0.35	0.32	0.26	0.24	0.22	0.21	0.19	0.19	0.17	0.15	0.14	0.13	0.12	0.06					22R500TR

**American ACME**

Pitch (thread/inch)	Total Cutting Depth	Number of Passes														Insert Type				
		1	2	3	4	5	6	7	8	9	10	11	12	13	14					
12	1.19	0.27	0.23	0.20	0.17	0.14	0.12	0.06												MMT16R120ACME
10	1.52	0.29	0.25	0.21	0.18	0.16	0.14	0.12	0.11	0.06										16R100ACME
8	1.84	0.30	0.26	0.22	0.19	0.16	0.15	0.14	0.13	0.12	0.11	0.06								16R080ACME
6	2.37	0.34	0.30	0.27	0.24	0.21	0.19	0.16	0.14	0.12	0.12	0.11	0.11	0.06						22R060ACME
5	2.79	0.36	0.33	0.30	0.26	0.23	0.20	0.18	0.17	0.16	0.15	0.14	0.13	0.12	0.06					22R050ACME

**API Buttress Casing**

Pitch (thread/inch)	Total Cutting Depth	Number of Passes														Insert Type				
		1	2	3	4	5	6	7	8	9	10	11								
5	1.55	0.25	0.23	0.17	0.15	0.13	0.12	0.12	0.11	0.11	0.10	0.06								MMT22R050APBU

**API Round Casing&Tubing**

Pitch (thread/inch)	Total Cutting Depth	Number of Passes														Insert Type				
		1	2	3	4	5	6	7	8	9	10	11	12							
10	1.41	0.25	0.23	0.16	0.14	0.12	0.12	0.12	0.11	0.10	0.06									MMT16R100APRD
8	1.81	0.25	0.24	0.19	0.16	0.14	0.14	0.13	0.13	0.13	0.13	0.11	0.06							16R080APRD

**American NPT**

Pitch (thread/inch)	Total Cutting Depth	Number of Passes															Insert Type			
		1	2	3	4	5	6	7	8	9	10	11	12	13	14	15				
27	0.66	0.15	0.13	0.12	0.11	0.09	0.06													MMT16R270NPT
18	1.01	0.20	0.16	0.14	0.13	0.12	0.11	0.09	0.06											16R180NPT
14	1.33	0.23	0.19	0.16	0.14	0.13	0.12	0.11	0.10	0.09	0.06									16R140NPT
11.5	1.64	0.24	0.19	0.17	0.15	0.15	0.13	0.13	0.12	0.11	0.10	0.09	0.06							16R115NPT
8	2.42	0.33	0.28	0.23	0.20	0.18	0.16	0.15	0.14	0.13	0.12	0.12	0.11	0.11	0.10	0.06				16R080NPT

**American NPTF**

Pitch (thread/inch)	Total Cutting Depth	Number of Passes															Insert Type			
		1	2	3	4	5	6	7	8	9	10	11	12	13	14	15				
14	1.35	0.23	0.21	0.16	0.14	0.13	0.12	0.11	0.10	0.09	0.06									MMT16R140NPTF
11.5	1.63	0.24	0.23	0.19	0.15	0.13	0.11	0.11	0.11	0.10	0.10	0.10	0.06							16R115NPTF
8	2.38	0.32	0.27	0.23	0.19	0.17	0.16	0.15	0.14	0.13	0.12	0.12	0.11	0.11	0.10	0.06				16R080NPTF

- (Note) • Set the finishing allowance on a diameter at approx. 0.1mm when using a full form insert.  
 • Please note the cutting depth and the number of passes when a nose radius of a partial form insert or of an internal threading insert is small to prevent damage to the insert nose.  
 • Please set the cutting depth sufficiently deep enough on materials such as hardened steel or austenitic stainless steel to help prevent premature wear and chipping caused by the outer layer of the material.

## TROUBLE SHOOTING

Problems	Observation	Causes	Solutions	
Low thread precision.	Threads do not mesh with each other.	Incorrect tool installation.	Set the insert centre height at 0mm. Check holder inclination (Lateral).	
		Shallow thread.	Modify the depth of cut. Refer to "Quickly generated flank wear." and "Large plastic deformation." below.	
	Poor surface finish.	Surface damage.	Chips wrap around or clog the work pieces.	Change to flank infeed and control the chip discharge direction. Change to an M-class insert with a 3-D chip breaker.
The side of the insert cutting edge interferes with the workpiece.			Check the lead angle and select an appropriate shim.	
Surface tears.			Built-up edge (Welding).	Increase cutting speed. Increase coolant pressure and volume.
		Cutting resistance too high.	Decrease depth of cut per pass.	
Surface vibrations.		Cutting speed too high.	Decrease the cutting speed.	
		Insufficient work piece or tool clamping.	Re-check work piece and tool clamping. (Chuck pressure, clamping allowance)	
		Incorrect tool installation.	Set the insert centre height at 0mm.	
Short tool life.		Flank wear quickly generated.	Cutting speed too high.	Decrease the cutting speed.
			Too many passes causes abrasive wear.	Reduce the number of passes.
			Small depth of cut for the finishing pass.	Do not re-cut at 0mm depth of cut, larger than 0.05mm depth of cut is recommended.
	Non-uniform wear of the right and left sides of the cutting edge.	The work piece lead angle and the tool lead angle do not match.	Check the work piece lead angle and select an appropriate shim.	
		Chipping and fracture.	Cutting speed too low.	Increase cutting speed.
	Cutting resistance too high.		Increase the number of passes and decrease the cutting resistance per pass.	
	Unstable clamping.		Check work piece deflection. Shorten tool overhang. Re-check work piece and tool clamping. (Chuck pressure, clamping allowance)	
			Chip packing.	Increase coolant pressure to blow away chips. Change the tool pass to control chips. (Lengthen each pass to allow the coolant to clear the chips. Change from standard internal cutting to back turning to prevent chip jamming.
				Non-chamfered work pieces causes high resistance at the start of each pass.
	Large plastic deformation.			High cutting speed and large heat generation.
			Lack of coolant supply.	Check coolant is supply is sufficient. Increase coolant pressure and volume.
		Cutting resistance too high.		Increase the number of passes and decrease the cutting resistance per pass.

# Memo

---

A series of horizontal dashed lines for writing, spanning the width of the page.